



Designation: D6723 – 02

Standard Test Method for Determining the Fracture Properties of Asphalt Binder in Direct Tension (DT)¹

This standard is issued under the fixed designation D6723; the number immediately following the designation indicates the year of original adoption or, in the case of revision, the year of last revision. A number in parentheses indicates the year of last reapproval. A superscript epsilon (ϵ) indicates an editorial change since the last revision or reapproval.

1. Scope

1.1 This test method covers the determination of the failure strain and failure stress of asphalt binders by means of a direct tension test. It can be used with unaged material or with material aged using Test Method D2872 (RTFOT), Practice D6521 (PAV), or AASHTO T 240 (RTFOT) and AASHTO PPI (PAV). The test apparatus is designed for testing within the temperature range from +6 to -36°C.

1.2 This test method is limited to asphalt binders containing particulate material having dimensions less than 250 μm .

1.3 The values stated in SI units are to be regarded as the standard.

1.4 *This standard does not purport to address all of the safety concerns, if any, associated with its use. It is the responsibility of the user of this standard to establish appropriate safety and health practices and determine the applicability of regulatory limitations prior to use.*

2. Referenced Documents

2.1 *ASTM Standards:*²

C670 Practice for Preparing Precision and Bias Statements for Test Methods for Construction Materials

D8 Terminology Relating to Materials for Roads and Pavements

D140 Practice for Sampling Bituminous Materials

D2872 Test Method for Effect of Heat and Air on a Moving Film of Asphalt (Rolling Thin-Film Oven Test)

D6373 Specification for Performance Graded Asphalt Binder

D6521 Practice for Accelerated Aging of Asphalt Binder Using a Pressurized Aging Vessel (PAV)

E1 Specification for ASTM Liquid-in-Glass Thermometers

E4 Practices for Force Verification of Testing Machines

E77 Test Method for Inspection and Verification of Thermometers

E83 Practice for Verification and Classification of Extensometer Systems

E220 Test Method for Calibration of Thermocouples By Comparison Techniques

E691 Practice for Conducting an Interlaboratory Study to Determine the Precision of a Test Method

2.2 *Deutsche Industrie Norm (DIN) Standard:*

43760 Standard for Calibrating Thermocouples³

2.3 *AASHTO Standards:*

T 240⁴

PPI (PAV)⁴

3. Terminology

3.1 *Definitions*—For definitions of general terms used in this standard, refer to Terminology D8.

3.2 *Definitions of Terms Specific to This Standard:*

3.2.1 *brittle, adj*—type of failure in a direct tension test where the stress-strain curve is essentially linear up to the point of failure and the failure is by sudden rupture of the test specimen without appreciable reduction in cross-section of the specimen.

3.2.2 *brittle-ductile, adj*—type of failure in a direct tension test where the stress-strain curve is curvilinear and the failure is by sudden rupture of the test specimen. Limited reduction in cross-section of the specimen occurs before rupture.

3.2.3 *ductile, adj*—type of failure in a direct tension test where the specimen does not rupture but fails by flow at large strains.

3.2.4 *effective gage length, n*—for specimens used in this test, the effective gauge length, L_e , has been determined to be 33.8 mm. This is an effective gauge length that represents the portion of the specimen that contributes to the majority of the strain.

3.2.5 *failure, n*—point at which the tensile load reaches a maximum value as the test specimen is pulled at a constant rate of elongation.

¹ This test method is under the jurisdiction of ASTM Committee D04 on Road and Paving Materials and is the direct responsibility of Subcommittee D04.44 on Rheological Tests.

Current edition approved Jan. 10, 2002. Published March 2002. Originally published as D6723 – 01. Last previous edition D6723 – 01. DOI: 10.1520/D6723-02.

² For referenced ASTM standards, visit the ASTM website, www.astm.org, or contact ASTM Customer Service at service@astm.org. For *Annual Book of ASTM Standards* volume information, refer to the standard's Document Summary page on the ASTM website.

³ Deutsches Institut für Normung e.V. (German Standards Institute), Beuth Verlag GmbH, Burggrafenstrasse 6, 10787, Berlin Germany.

⁴ Available from the American State Highway and Transportation Officials, 444 N. Capitol Street, N.W., Washington, DC 20001.

3.2.6 *failure strain, n* —the tensile strain corresponding to the failure stress.

3.2.7 *failure stress, n* —the tensile stress on the test specimen when the load reaches a maximum value during the test method specified in this standard.

3.2.8 *gage section, n* —the central portion of the specimen where the cross-section does not change with length. For the geometry used in this test method, the gage section is 18 mm in length (see Fig. 1).

3.2.9 *tensile strain, n* —axial strain resulting from the application of a tensile load and calculated as the change in length of the effective gage length caused by the application of the tensile load divided by the original unloaded effective gage length.

3.2.10 *tensile stress, n* —axial stress resulting from the application of a tensile load and calculated as the tensile load divided by the original area of cross-section of the specimen.

4. Summary of Test Method

4.1 This test method describes the procedure used to measure the stress at failure and strain at failure in an asphalt binder test specimen pulled at a constant rate of elongation. Test specimens are prepared by pouring hot asphalt binder into a suitable mold. Two plastic end tabs are used to bond the asphalt binder during the test and to transfer the tensile load from the test machine to the asphalt binder.

4.2 This test method was developed for asphalt binders at temperatures where they exhibit brittle or brittle-ductile failure. A brittle or brittle-ductile failure will result in a fracture of the test specimen as opposed to a ductile failure in which the specimen simply stretches without fracturing. The test method is not applicable at temperatures where failure is by ductile flow.

4.3 A displacement transducer is used to measure the elongation of the test specimen as it is pulled in tension at a constant rate of 1.00 mm/min. The load developed during the test is monitored and the tensile strain and stress in the test specimen when the load reaches a maximum are reported as the failure strain and failure stress, respectively.

5. Significance and Use

5.1 Stress at failure is used in a mechanistic pavement cracking model to compute critical cracking temperature. The procedure to compute critical cracking temperature is described in Practice D6521. The critical cracking temperature is then used in specifying the low temperature grade of asphalt binder in accordance with Specification D6373.

5.2 The test method is designed to measure the strength of the asphalt binder at the critical cracking temperature. The asphalt binder has limited ability to resist stress without cracking. In the asphalt binder Specification D6373, failure stress is used to determine the critical cracking temperature.

5.3 For evaluating an asphalt binder for conformance to Specification D6373, the elongation rate of the gage section is 1.0 mm/min and the test temperature is selected from Table number 1 of Specification D6373 according to the grade of asphalt binder. Other rates of elongation and test temperatures may be used to test asphalt binders.

6. Apparatus

6.1 *Direct Tension Test System*—A direct tension test system consisting of (1) a closed feed-back loop displacement-controlled tensile loading machine, (2) a specimen gripping system, (3) either a fluid bath or an insulated chamber for reliable, accurate and uniform temperature control during testing and conditioning of specimen, (4) real-time load measuring and recording devices, (5) real-time elongation measuring and recording devices, (6) a real-time temperature detection and recording device, and (7) real-time data acquisition and display devices. The system shall have an electro-mechanical or servo-hydraulic loading unit capable of applying and measuring tension and compression forces of at least 500 N and actuator travel of 20 mm. The system stiffness shall be at least 3 MN/m including the load cell and the loading pins. The unit shall have a transducer to measure and control grip separation and provide a feedback for strain control with a displacement resolution of 1.0 μ m. The system shall be capable of closed loop elongation rate control accurate to at least 1 % of the commanded specimen elongation rate using feedback from a displacement transducer mounted between the loading pins or a non-contact extensometer measuring the elongation of the specimen.

6.1.1 *Tensile Loading Machine Equipped With Temperature Control*—A tensile loading machine with a controlled-displacement loading frame capable of producing at least a 500.00 N load is required. The loading frame shall be table mounted. The gripping system (loading pins and platens) shall be completely submerged under the cooling fluid if a fluid based system is used. The gripping system shall be a minimum of 25 mm under the cooling fluid surface. Loading shall be accomplished by pulling directly in tension in the plane of the specimen. The distance between the load frame's loading points (between loading pins) shall accommodate specimens with total length (including the end tabs) of at least 100.0 mm, (see Fig. 1). If an air cooled system is used, the testing frame shall be equipped with two standards (columns) with sufficient clear space between the standards so that an insulated temperature control chamber can be placed between the standards.

6.1.2 *Specimen Gripping System*—The gripping system must produce a self-aligning uniaxial test load and accept the end tabs described in 6.1.2.1 and be designed so that test specimens can be easily mounted in the machine. The system shall include two grips. Each grip shall include a specially-shaped pin that is mounted rigidly to the loading platens of the testing machine. Fig. 2 shows a typical grip and loading pin assembly. One grip shall be fixed and remain stationary during the test while the other grip is displaced at the desired elongation rate.

6.1.2.1 *Specimen End Tabs*—End tabs made from Phenolic G-10 material having the dimensions specified in Figs. 3-5 shall be bonded to both ends of the test specimen to transfer the tensile load to the asphalt binder. The end tabs shall be machined from standard G-10 Phenolic sheet. Each end tab shall contain a precisely machined hole lined with a 304 stainless steel ring. The diameter of the lined hole shall be 10.00 ± 0.05 mm. Gripping of the specimen is accomplished through the bond (adhesion) between the asphalt binder test

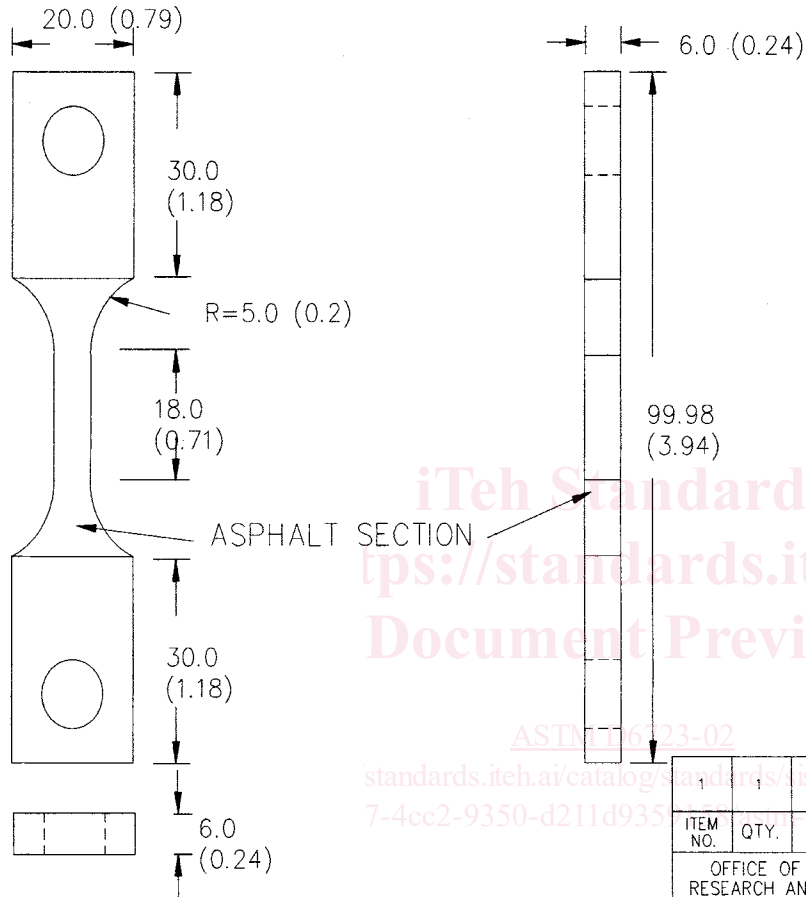

DIRECT TENSION TEST
GEOMETRY

- NOTES:
- 1.) ALL DIMENSIONS ARE IN MILLIMETERS. (INCHES IN PARENTHESIS)
 - 2.) TOLERANCES ARE AS FOLLOWS: FRACTIONS= ± 1.6 (1/16")
 $X.X = \pm 0.8$ (.03)
 $X.XX = \pm 0.25$ (.01)
 $X.XXX = \pm 0.12$ (.005)
 ANGLES= $\pm 30'$
 - 3.) REMOVE ALL SHARP EDGES.
 - 4.) SURFACE FINISH FOR MACHINED SURFACES: $\sqrt{125}$ UNLESS OTHERWISE SPECIFIED.

iTeh Standards
<https://standards.itih>
 Document Preview

ASTM D6723-02

standards.itih.ai/catalog/standards/ast/8a7-4cc2-9350-d211d935-d6723-02

ITEM NO.	1	GEOMETRY	NOT MANUFACTURED
QTY.		NOMENCLATURE	SPECIFICATION
OFFICE OF ENGINEERING RESEARCH AND DEVELOPMENT SPECIAL PROJECTS AND ENGINEERING DIVISION TURNER-FAIRBANK HIGHWAY RESEARCH CENTER		U.S. DEPT. OF TRANSPORTATION FEDERAL HIGHWAY ADMINISTRATION RESEARCH AND DEVELOPMENT	
DRAWN:	KB	DATE	DIRECT TENSION TEST GEOMETRY
CHECKED:		DATE	
APPROVED:		DATE	
ORGANIZATION		SIZE	DWG. NO. DTGEO1 REV. A
SCALE: NONE		SHEET 1 OF 1	

FIG. 1 Superpave Direct Tension Specimen Geometry

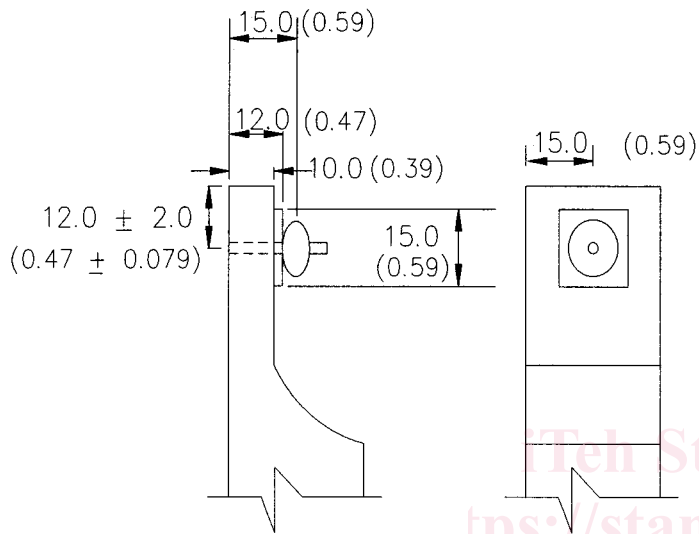

PRESS FIT PIN

TYPICAL GRIP SHOWING THE PIN PRESS-FITTED.
TWO GRIPS ARE NEEDED.

ASTM D6723-02

standards.iteh.ai/catalog/standards/sist/8aa7-4cc2-9350-d211d935

NOTES:

- 1.) ALL DIMENSIONS ARE IN MILLIMETERS. (INCHES IN PARENTHESIS)
- 2.) TOLERANCES ARE AS FOLLOWS: FRACTIONS= ± 1.6 (1/16")
 $X.X = \pm 0.8$ (.03)
 $X.XX = \pm 0.25$ (.01)
 $X.XXX = \pm 0.12$ (.005)
 ANGLES = $+30'$
- 3.) REMOVE ALL SHARP EDGES.
- 4.) SURFACE FINISH FOR MACHINED SURFACES: $125 \sqrt{\text{UNLESS}}$ OTHERWISE SPECIFIED.

ITEM NO.	QTY.	NOMENCLATURE	SPECIFICATION
1	2	GRIP	316 STAINLESS STEEL
OFFICE OF ENGINEERING RESEARCH AND DEVELOPMENT SPECIAL PROJECTS AND ENGINEERING DIVISION TURNER-FAIRBANK HIGHWAY RESEARCH CENTER		U.S. DEPT. OF TRANSPORTATION FEDERAL HIGHWAY ADMINISTRATION RESEARCH AND DEVELOPMENT	
DRAWN: KB		DATE	
CHECKED:		DATE	
APPROVED:		DATE	
ORGANIZATION		SIZE	DWG. NO. DTLPG1
		SCALE: NONE	REV. A
			SHEET 1 OF 1

FIG. 2 Loading Pin and Grip Assembly for the Superpave Direct Tension Test

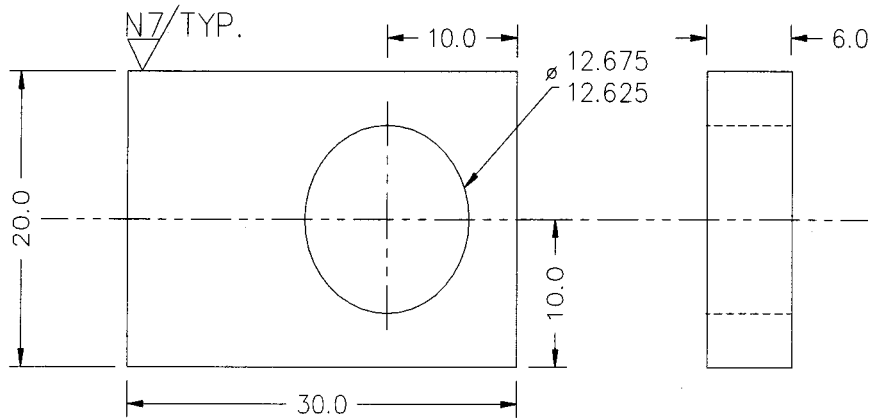

NOTES:

1. MATERIAL : G-10 Phenolic
2. Also See Metal Ring and Assembly Drawings.

NOTES:

- 1.) ALL DIMENSIONS ARE IN MILLIMETERS. (INCHES IN PARENTHESIS)
- 2.) TOLERANCES ARE AS FOLLOWS: FRACTIONS= $\pm 1.6 (1/16")$
 $X.X = \pm .8 (.03)$
 $X.XX = \pm .25 (.01)$
 $X.XXX = \pm .12 (.005)$
 ANGLES= $\pm 30'$
- 3.) REMOVE ALL SHARP EDGES.
- 4.) SURFACE FINISH FOR MACHINED SURFACES: $\sqrt{125}$ UNLESS OTHERWISE SPECIFIED.

ITEM NO.	QTY.	NOMENCLATURE	SPECIFICATION
		OFFICE OF ENGINEERING RESEARCH AND DEVELOPMENT SPECIAL PROJECTS AND ENGINEERING DIVISION TURNER-FAIRBANK HIGHWAY RESEARCH CENTER	U.S. DEPT. OF TRANSPORTATION FEDERAL HIGHWAY ADMINISTRATION RESEARCH AND DEVELOPMENT
DRAWN:	KB	DATE	END TAB FOR METAL RING
CHECKED:		DATE	
APPROVED:		DATE	
ORGANIZATION		SIZE	DWG. NO. DTINS41
			REV. A
SCALE: NONE		SHEET 1 OF 1	

FIG. 3 Superpave End Insert for Direct Tension Test (See Fig. 4 for the Metal Ring Dimensions to be Press Fitted into this End Insert)

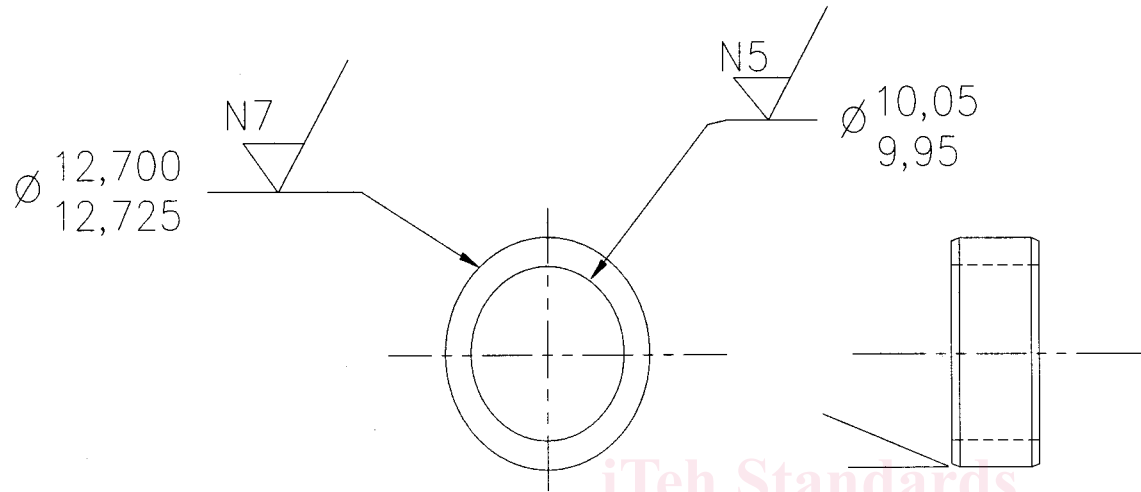

NOTES:

1. MATERIAL: ST. ST. TYPE 316 OR 304
MAY BE MADE FROM 1/4" SCHEDULE 40
SEAMLESS PIPE

NOTES:

- 1.) ALL DIMENSIONS ARE IN MILLIMETERS. (INCHES IN PARENTHESIS)
- 2.) TOLERANCES ARE AS FOLLOWS: FRACTIONS= ± 1.6 (1/16")
 $X.X = \pm .8$ (.03)
 $X.XX = \pm .25$ (.01)
 $X.XXX = \pm .12$ (.005)
 ANGLES= $\pm 30'$
- 3.) REMOVE ALL SHARP EDGES.
- 4.) SURFACE FINISH FOR MACHINED SURFACES: $\sqrt{125}$ UNLESS OTHERWISE SPECIFIED.

ASTM D6723-02
standards.iteh.ai/catalog/standards/sist/8aac7-4cc2-9350-d211d9351158/astm-d6723-02

ITEM NO.	QTY.	NOMENCLATURE	SPECIFICATION
OFFICE OF ENGINEERING RESEARCH AND DEVELOPMENT SPECIAL PROJECTS AND ENGINEERING DIVISION TURNER-FAIRBANK HIGHWAY RESEARCH CENTER		U.S. DEPT. OF TRANSPORTATION FEDERAL HIGHWAY ADMINISTRATION RESEARCH AND DEVELOPMENT	
DRAWN:	KB	DATE	RING, END TAB
CHECKED:		DATE	
APPROVED:		DATE	
ORGANIZATION		SIZE	DWG. NO. DTINS42 REV. A
SCALE: NONE		SHEET 1 OF 1	

FIG. 4 Superpave End Insert Metal Ring for Direct Tension Test