

23

International Standard



7915

INTERNATIONAL ORGANIZATION FOR STANDARDIZATION • МЕЖДУНАРОДНАЯ ОРГАНИЗАЦИЯ ПО СТАНДАРТИЗАЦИИ • ORGANISATION INTERNATIONALE DE NORMALISATION

**Forestry machinery — Portable chain-saws — Handles —
Determination of strength**

Matériel forestier — Scies à chaîne portatives — Poignées — Détermination de la solidité

First edition — 1985-10-15

UDC 621.936.6 : 634.0.36

Ref. No. ISO 7915-1985 (E)

Descriptors : agricultural machinery, forest equipment, portable equipment, saws, handles, tests, static tests.

ISO 7915-1985 (E)

Price based on 2 pages

Foreword

ISO (the International Organization for Standardization) is a worldwide federation of national standards bodies (ISO member bodies). The work of preparing International Standards is normally carried out through ISO technical committees. Each member body interested in a subject for which a technical committee has been established has the right to be represented on that committee. International organizations, governmental and non-governmental, in liaison with ISO, also take part in the work.

Draft International Standards adopted by the technical committees are circulated to the member bodies for approval before their acceptance as International Standards by the ISO Council. They are approved in accordance with ISO procedures requiring at least 75 % approval by the member bodies voting.

International Standard ISO 7915 was prepared by Technical Committee ISO/TC 23, *Tractors and machinery for agriculture and forestry*.

Users should note that all International Standards undergo revision from time to time and that any reference made herein to any other International Standard implies its latest edition, unless otherwise stated.

Forestry machinery — Portable chain-saws — Handles — Determination of strength

1 Scope and field of application

This International Standard specifies a test method and the requirements for the strength of the handles of portable hand-held combustion engine chain-saws for use primarily in forestry.

2 References

ISO 6533, *Forestry machinery — Portable chain saws — Front hand guard — Dimensions.*

ISO 7914, *Forestry machinery — Portable chain-saws — Minimum handle clearance and sizes.*¹⁾

3 Test procedure

The test temperature shall be 20 ± 5 °C.

The chain-saw handles shall be subjected to static loads as specified in the table, separately applied at the handle grip midpoint, in each of the six directions illustrated in the figure. In each case the chain-saw shall be fixed rigidly by the guide-bar clamped in a vice with a minimum clearance of 15 mm between the vice and any part of the body of the saw, so that they do not touch during the test.

The load shall be applied over an area of not more than 75 mm in width, centred on the normal hand-grip area for both the front and rear handles. Where necessary, brackets may be clamped to the handles to facilitate side loading or loading in the Z direction.

The load direction shall remain constant relative to the mounting, despite any deflections of the handles or saw.

Table — Handle strength test loads

Chain-saw engine displacement cm ³	Minimum test loads		
	Front and rear X ₁ and X ₂	Up and down Y ₁ and Y ₂	Right and left Z ₁ and Z ₂
< 50	900	900	450
> 50 and < 82	1 350	1 350	650
> 82	1 800	1 800	900

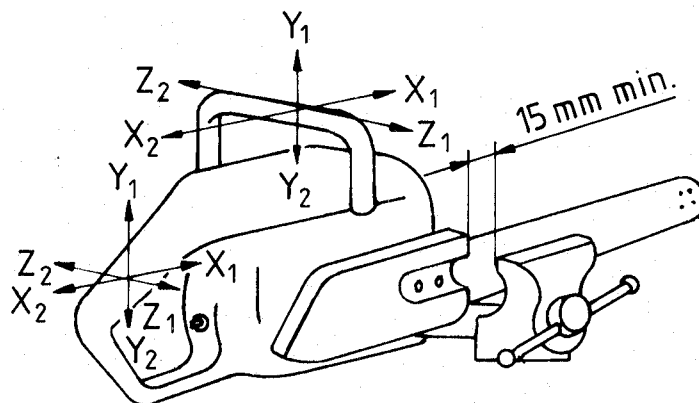

Figure — Directions of load applications

1) At present at the stage of draft.