



## Standard Specification for Cast Iron Soil Pipe and Fittings<sup>1</sup>

This standard is issued under the fixed designation A 74; the number immediately following the designation indicates the year of original adoption or, in the case of revision, the year of last revision. A number in parentheses indicates the year of last reapproval. A superscript epsilon (ε) indicates an editorial change since the last revision or reapproval.

*This standard has been approved for use by agencies of the Department of Defense.*

### 1. Scope

1.1 This specification covers cast iron soil pipe and fittings for use in gravity flow applications. It establishes standards covering material, principal dimensions, and dimensional tolerances for extra heavy and service cast iron soil pipe and fittings. These pipe and fittings are not intended for pressure applications as the selection of the proper size for drain, waste, vent, and storm drain systems allows free air space for gravity drainage.

1.2 This specification covers pipe and fittings of the following patterns and, when so designated, shall apply to any other patterns that conform with the requirements given herein.

#### 1.2.1 Pipe:

Extra heavy, 5 ft (1.5 m), 10 ft (3.0 m) lengths	Tables 1, 2
Service, 5 ft, 10 ft	1, 2
Outside dimensions (for detailing)	X1.1

#### 1.2.2 Fittings:

¼ bends; long ¼ bends	Tables 3, 4
¼ bends, long low-hub	5
¼ bends, low heel; high heel	6, 7
¼ bends, short sweep; long sweep	8
¼ bends, reducing long sweep	9
½ bends	10
⅝ bends	10
¾ bends; long ¾ bends	11
⅞ bends	11
Y branches	12, 13
Y branches, cleanout on main	14
Y branches, cleanout on branch	15
Y branches, inverted	16
Y branches, combination ¼ bends, single	17
Y branches, combination ¼ bends, double	17
Y branches, combination ¼ bends, cleanout	18
Y branches, upright	19
Sanitary T branches, single	20
Sanitary T branches, double	20

Sanitary T branches, cleanout	Tables 21
Tapped sanitary T branches, single	22
Tapped sanitary T branches, double	22
T branches, single and double	23
Tapped T branches, single	24
Tapped T branches, double	24
Horizontal twin tapped T	25
T branches, cleanout	26
Vent branches, single	27
Offsets, ½ bend	28
Double hubs	29
Long double hubs	29
Reducers	30
Increases	31, 32
S traps	33
P traps	34, 35
Deep seal P traps	36
Running traps	37
Screw plugs (brass)	38
Blind plugs	39
Iron-body ferrules	40
Side inlets	Fig. 3
Closet bends	41
Tapping bosses	42

1.3 The values stated in inch-pound units are to be regarded as the standard. The values given in parentheses are for information only.

### 2. Referenced Documents

#### 2.1 ASTM Standards:

- A 48 Specification for Gray Iron Castings<sup>2</sup>
- A 438 Test Method for Transverse Testing of Gray Cast Iron<sup>2</sup>
- A 644 Terminology Relating to Iron Castings<sup>2</sup>
- E 8 Test Methods for Tension Testing of Metallic Materials<sup>3</sup>
- E 23 Test Methods for Notched Bar Impact Testing of Metallic Materials<sup>3</sup>

#### 2.2 Federal Standard:

- Fed. Std. No. 123 Marking for Shipment (Civil Agencies)<sup>4</sup>

#### 2.3 Military Standard:

<sup>1</sup> This specification is under the jurisdiction of ASTM Committee A04 on Iron Castings and is the direct responsibility of Subcommittee A04.12 on Pipes and Tubes.

Current edition approved Jan. 10, 1998. Published September 1998. Originally published as A 74 – 17 T. Last previous edition A 74 – 96.

<sup>2</sup> *Annual Book of ASTM Standards*, Vol 01.02.

<sup>3</sup> *Annual Book of ASTM Standards*, Vol 03.01.

<sup>4</sup> Available from Standardization Documents Order Desk, Bldg. 4 Section D, 700 Robbins Ave., Philadelphia, PA 19111-5094, Attn: NPODS.

MIL-STD-129 Marking for Shipment and Storage<sup>4</sup>

2.4 ANSI Standard:

B1.20.1 Pipe Threads<sup>5</sup>

**3. Materials and Manufacture**

3.1 The pipe and fittings shall be iron castings suitable for installation and service for sanitary, storm drain, waste, and vent piping applications. They shall meet all applicable requirements and tests given herein.

3.2 The castings shall be made of cast iron, produced by an established commercial method that provides adequate control over chemical and physical properties. Cast iron is a generic term for a series of alloys as defined in Terminology A 644 and includes gray iron as well as ductile iron. The castings shall be sound, true to pattern, and of compact close grain that permits drilling and cutting by ordinary methods. The interior surface shall be reasonably smooth and free from defects which would make the castings unfit for the use for which they are intended.

**4. Mechanical Properties**

4.1 *Mechanical Tests for Gray Iron*—When requested, tests shall be made to determine mechanical properties of the gray iron used in the manufacture of gray iron soil pipe and fittings. Either transverse (flexure) test bars, or tension test specimens shall be employed.

4.1.1 *Transverse Bend Test*—The breaking load shall be not less than 1750 lb (7800 N), and the deflection at the point of application of the load shall be not less than 0.20 in. (5.1 mm).

4.1.2 *Tensile Strength Test*—The tensile strength shall be not less than 21 000 psi (145 MPa).

**5. Dimensions and Permissible Variations**

5.1 *Pipe:*

5.1.1 Single-hub pipe shall have a hub at one end and a spigot at the other. Double hub pipe shall have a hub at each end. Hubs shall have lead grooves. The inner end of hub shall be either with or without a centering recess, all combinations of which shall make a satisfactory leakproof joint. Hub and barrel shall be cast in one piece (see Fig. 1).

Table 2. Double-hub pipe shall be of the same overall length as single-hub pipe of the same size. Its laying length shall be 5 ft minus the two telescoping lengths (dimension Y), or 10 ft minus the telescoping length (dimension Y). Other dimensions shall be as specified in Table 1 as applicable, and be within the tolerances specified in Table 2. The dimensions shall apply to pipe before any coating is applied.

5.1.3 Pipe shall be straight to the extent that any deflections in the barrel of a 2½-ft, 3½-ft, and 5-ft length of pipe shall not exceed ¼ in. (6.4 mm) for sizes 4 in. (102 mm) and larger, and shall not exceed ⅕ in. (7.9 mm) for smaller sizes: for 10-ft lengths, deflections in the barrel shall not exceed ½ in. (12.7 mm) for sizes 4 in. and larger, nor exceed ⅝ in. (15.9 mm) for smaller sizes.

5.2 *Fittings:*

5.2.1 *Dimensions of Fittings*—All fittings shall conform to the dimensions specified for hub and spigot ends in Table 1 and Table 2, as applicable. Fittings of the patterns specified herein shall conform to the applicable dimensions in Tables 3-42 inclusive, and to the tolerances in Table 2. Other patterns (Note 1) shall conform to Table 1, as applicable, for hub and spigot dimensions, and for wall thickness throughout, and to dimension R', Tables 20-22, for the minimum radius of any drainage inlets that such fittings may provide. All fittings shall have spigot ends of sufficient length to provide adequate room for making leakproof joints. All dimensions given herein shall apply to fittings before any coating is applied.

NOTE 1—Such as, for example, fittings known in the trade as “specials,” when designated as being in conformity with this specification.

5.2.2 *Water Seal and Traps*—Traps shall have water seals as follows:

Trap Size, in. (mm)	Minimum Water seal, in. (mm)
2 (50)	2 (50)
3 to 6 (80 to 150), incl	2½ (64)
8 to 12 (200 to 300), incl	3 (80)

5.2.3 *Ends of Fittings*—Hubs shall have lead grooves. The inner end of hub may be either with or without a centering

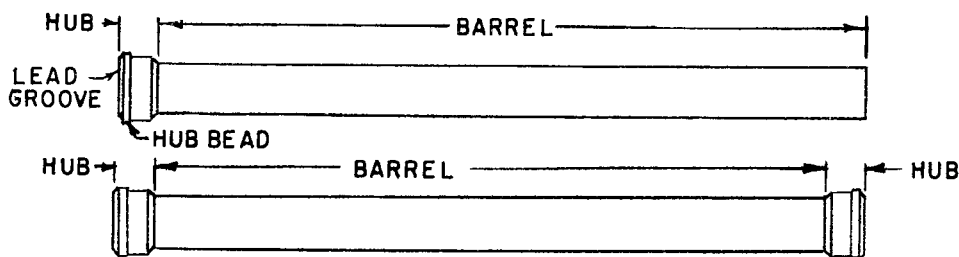

**FIG. 1 Single-Hub and Double-Hub Cast Iron Soil Pipe Laying Lengths**

5.1.2 Single-hub pipe shall be of 2½-ft (0.76-m), 3½-ft (1.07-m), 5-ft (1.5-m), and 10-ft (3.0-m) nominal laying lengths. The laying length shall be as shown in Table 1 and shall be within the tolerances on laying length specified in

recess, all combinations of which shall make a satisfactory joint. Tapped openings shall conform to 5.2.4. It is permissible to increase the wall thickness on the inside surface of fittings having one or more plain ends. The increased thickness shall not reduce the minimum B dimension in Table 1 in excess of 0.06 in. and shall not extend more than 4 ¼ in. from the plain end. The increased thickness shall be tapered and offer no

<sup>5</sup> Available from American National Standards Institute, 11 West 42nd Street, 13th Floor, New York, NY 10036.

 **A 74**

obstruction to flow. Inside diameters complying with service4 or extra heavy inside diameters shall be permitted on 15 in.-sized only.

5.2.4 *Pipe Threads*—Screw plugs and tapped openings in fittings shall have American Standard taper pipe threads. The threads shall be in accordance with the American National Standard for Pipe Threads, B2.1, or with the National Bureau of Standards Handbook 28; Screw Thread Standards for Federal Services, of the current issue.

5.2.5 Internal threads shall be chamfered at the entering end approximately to the major diameter of the thread, at an angle of approximately 45° with the axis of the thread, and the entering end of external threads shall be similarly chamfered approximately to be minor diameter of the thread, for easy entrance in making a joint and for protection of the thread. The chamfer shall be concentric with the thread and shall be included in measurements of thread length.

## 6. Methods of Specifying Fittings

6.1 *Method of Specifying Sizes of Fittings of More than One Size*—The sizes are designated by the order of listing, as follows:

6.1.1 Branch and tapped fittings:

6.1.1.1 Size of run (Note 2), and

6.1.1.2 Size of branch.

6.1.2 Reducers, increasers, and offset fittings:

6.1.2.1 Size of inlet or run (Note 2),

6.1.2.2 Size of outlet or offset distance,

6.1.2.3 Length, if supplied in more than one length.

NOTE 2—The run is that portion of the fitting which forms part of the main drain, waste or vent line. The spigot end is ordinarily the outlet.

6.2 *Method of Specifying Hand of Fittings with Side Inlets and Outlets*—When placed in the position described below, if the side inlet or outlet appears on the right, it is a right-hand fitting; if on the left, it is a left-hand fitting.

6.2.1 *Bends and Offsets*—Place the fitting with hub facing toward the observer and the spigot end lower than the hub.

6.2.2 *Branch Fittings*—Place the branch toward the observer and the spigot end lower than the hub.

6.2.3 *Traps*—Place in the position in which the trap is installed, with the hub toward the observer.

6.2.4 The fittings shown in Fig. 2 have right-hand inlet or cleanout. Left-hand fittings have these openings on the side opposite to that shown. For details of side inlets, see Fig. 3.

## 7. Coating

7.1 The pipe and fittings shall be uniformly coated with a material suitable for the purpose, that is adherent, not brittle, and without a tendency to scale. The coating shall be evenly and smoothly applied to all surfaces except threaded openings.

## 8. Sampling

8.1 Chemical analyses shall be made regularly and at sufficiently close intervals for adequate determinations of the significant chemical constituents of the cast iron.

## 9. Test Methods

9.1 *Gray Iron:*

9.1.1 *Transverse Bend Test*—The transverse bend test shall be performed in accordance with the requirements of Test Method A 438. The test bar shall be 1.2 in. (30.5 mm) in diameter by 21 in. in length, and loaded at a point midway between supports 18 in. (457 mm) apart.

9.1.2 *Tensile Strength Test*—Test bars shall be cast in accordance with the requirements of Specification A 48. The tensile strength shall be determined in accordance with Test Methods E 8. Using Specimen 2, Fig. 6, Standard Test Specimen for Cast Iron.

## 10. Inspection

10.1 *Inspection and Test by the Manufacturer*—Pipe and fittings shall be thoroughly inspected by the manufacturer before shipment. On the sample pieces selected for inspection, the inside diameter of the hub and barrel and the outside diameter of the spigot end shall be checked by suitable gages. Fittings shall be suitably inspected for soundness and brittleness.

## 11. Certification

11.1 Upon request of the purchaser, the manufacturer shall be prepared to certify that his product conforms to the requirements of this specification.

## 12. Product Marking

12.1 Each length of pipe and each fitting shall be plainly marked with the country of origin, the manufacturer's initials or registered trademark by which the manufacturer can be readily identified after installation, and with letters to indicate the proper classification, as follows:

XH	Extra Heavy
SV	Service

The marking shall be cast, stenciled, or otherwise applied on the pipe so as to be clear and legible after installation. The marking shall be cast on fittings and shall be clear and legible after installation and located away from the spigot end so as not to interfere with proper joining upon installation.

## 13. Packaging and Package Marking

13.1 *Government Procurement*—Unless otherwise specified in the contract, the material shall be packaged in accordance with the supplier's standard practice which will be acceptable to the carrier at lowest rates. Containers and packing shall comply with Uniform Freight Classification Rules<sup>6</sup> or National Motor Freight Classification Rules.<sup>7</sup> Marking for shipment of such material shall be in accordance with Fed. Std. No. 123 for civil agencies and MIL-STD-129 for military agencies.

## 14. Keywords

14.1 cast iron; hub and spigot pipe; pipe; soil pipe

<sup>6</sup> Available from The Uniform Classification Commission, Room 1106, 222 S. Riverside Plaza, Chicago, IL 60606.

<sup>7</sup> Available from National Motor Freight Inc., 1616 P. St., N.W., Washington, DC 20036.

ASTM A 74

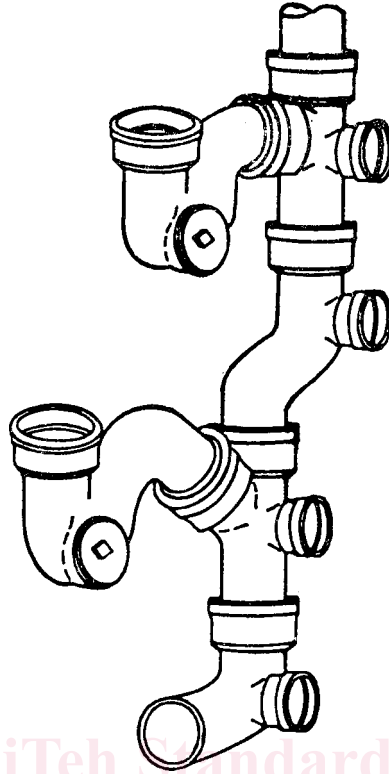
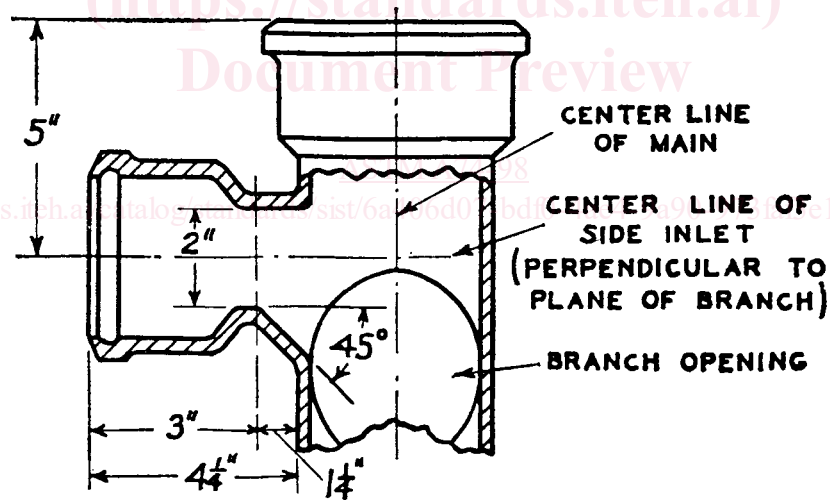

FIG. 2 Fittings with Right-Hand Inlet or Cleanout



NOTE 1—1 in. = 25.4 mm.

NOTE 2—Dimensions and location of 2-in. side inlet for single or double sanitary T branches and Y branches are shown above. Single and double sanitary T branches and single and double Y branches with 2-in. side inlets are standard in the following sizes only: 4 by 3 by 2-in.; 4 by 4 by 2-in.; 5 by 4 by 2-in.; 6 by 4 by 2-in.

FIG. 3 Dimensions and Locations for 2-in. Side Inlets

**ASTM A 74**

**TABLE 1 Dimensions of Hubs, Spigots, and Barrels for Extra-Heavy and Service Cast Iron Soil Pipe and Fittings, in.**

NOTE 1—1 in. = 25.4 mm; 1 ft = 0.3 m throughout tables.

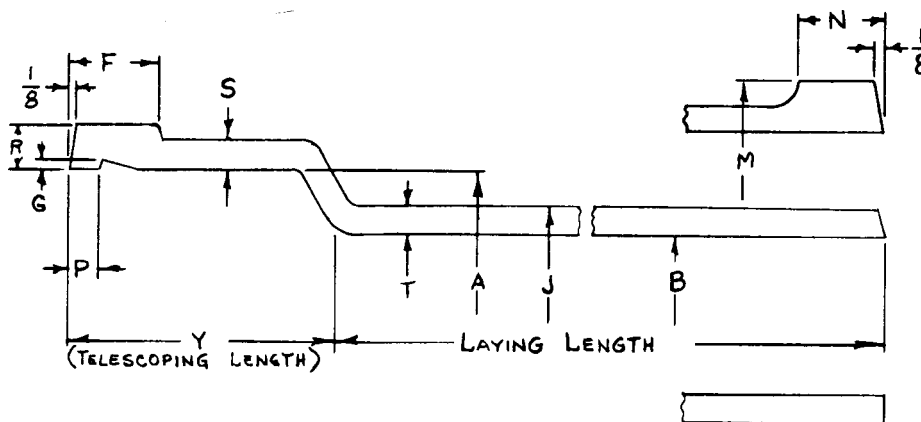

**Extra-Heavy Cast Iron Soil Pipe and Fittings:**

Size <sup>A</sup> Availability	Inside Diameter of Hub <sup>B</sup>	Outside Diameter of Barrel <sup>B</sup>	Telescoping Length <sup>B</sup>	Inside Diameter of Barrel <sup>B</sup>	Thickness of Barrel <sup>B</sup>	
	A	J	Y	B	T	
					Nom	Min
2*	3.06[77.72]	2.38[60.45]	2.50[63.5]	2.00[50.8]	0.19[4.83]	0.16[4.06]
3*	4.19[106.43]	3.50[88.9]	2.75[69.85]	3.00[76.2]	0.25[6.35]	0.22[5.59]
4*	5.19[131.83]	4.50[114.3]	3.00[76.2]	4.00[101.6]	0.25[6.35]	0.22[5.59]
5*	6.19[131.83]	5.50[139.7]	3.00[76.2]	5.00 [127]	0.25[6.35]	0.22[5.59]
6*	7.19[182.63]	6.50[165.1]	3.00[76.2]	6.00[152.4]	0.25[6.35]	0.22[5.59]
8*	9.50[241.30]	8.62[218.5]	3.50[88.9]	8.00[203.2]	0.31[7.87]	0.25[6.35]
10*	11.62[295.15]	10.75[273.05]	3.50[88.9]	10.00 [254]	0.37[9.40]	0.31[7.87]
12*	13.75[349.25]	12.75[323.85]	4.25[107.95]	12.00[304.8]	0.37[9.40]	0.31[7.87]
15*	16.95[430.53]	15.88[403.35]	4.25[107.95]	15.00 [381]	0.44[11.18]	0.38[9.65]

Size <sup>A</sup>	Thickness of Hub		Width of Hub Bead <sup>B,C</sup>	Distance from Lead Groove to End, Pipe and Fittings <sup>B</sup>	Depth of Lead Groove	
	Hub Body	Over Bead			G	
	S (min)	R (min)	F	P	G (min)	G (max)
2	0.18[4.57]	0.37[9.40]	0.75[19.05]	0.22[5.59]	0.10[2.54]	0.19[4.83]
3	0.25[6.35]	0.43[10.92]	0.81[20.57]	0.22[5.59]	0.10[2.54]	0.19[4.83]
4	0.25[6.35]	0.43[10.92]	0.88[22.35]	0.22[5.59]	0.10[2.54]	0.19[4.83]
5	0.25[6.35]	0.43[10.92]	0.88[22.35]	0.22[5.59]	0.10[2.54]	0.19[4.83]
6	0.25[6.35]	0.43[10.92]	0.88[22.35]	0.22[5.59]	0.10[2.54]	0.19[4.83]
8	0.34[8.64]	0.59[14.99]	1.19[30.23]	0.38[9.65]	0.15[3.81]	0.22[5.59]
10	0.40[10.16]	0.65[16.51]	1.19[30.23]	0.38[9.65]	0.15[3.81]	0.22[5.59]
12	0.40[10.16]	0.65[16.51]	1.44[36.54]	0.47[11.94]	0.15[3.81]	0.22[5.59]
15	0.46[11.68]	0.71[18.03]	1.44[36.54]	0.47[11.94]	0.15[3.81]	0.22[5.59]

**Service Cast Iron Soil Pipe:**

Size <sup>A</sup> Availability <sup>B</sup>	Inside Diameter of Hub <sup>B</sup>	Outside Diameter of Barrel <sup>D</sup>	Telescoping Length <sup>D</sup>	Inside Diameter of Barrel <sup>D</sup>	Thickness of Barrel <sup>D</sup>	
	A	J	Y	B	T	
					Nom	Min
20	2.94[74.68]	2.30[58.42]	2.50[63.5]	1.96[49.78]	0.17[4.32]	0.14[3.56]
30	3.94[100.08]	3.30[83.82]	2.75[69.85]	2.96[75.18]	0.17[4.32]	0.14[3.56]
40	4.94[125.48]	4.30[109.22]	3.00 [76.2]	3.94[100.08]	0.18[4.57]	0.15[3.81]
50	5.94[150.88]	5.30[134.62]	3.00[76.2]	4.94[125.48]	0.18[4.57]	0.15[3.81]
60	6.94[176.28]	6.30[160.02]	3.00[76.2]	5.94[150.88]	0.18[4.57]	0.15[3.81]
80	9.25[234.95]	8.38[212.85]	3.50[88.9]	7.94[201.68]	0.23[5.84]	0.17[4.32]
100	11.38[289.05]	10.50[266.70]	3.50[88.9]	9.94[252.48]	0.28[6.86]	0.22[5.59]
120	13.50[342.9]	12.50[317.5]	4.25[107.95]	11.94[303.28]	0.28[6.86]	0.22[5.59]
150	16.95[430.53]	15.88[403.35]	4.25[107.95]	15.16[385.06]	0.36[9.14]	0.30[7.62]



**TABLE 1** *Continued*

Size <sup>A</sup>	Thickness of Hub		Width of Hub Bead <sup>D</sup>	Distance from Lead Groove to End, Pipe and Fittings <sup>B</sup>	Depth of Lead Groove	
	Hub Body	Over Bead			G (min)	G (max)
	S (min)	R (min)	F (min)	P		
2	0.13[3.30]	0.34[8.64]	0.75 (0.63) [19.05] (16.00)	0.22[5.59]	0.10[2.54]	0.19[4.83]
3	0.16[4.06]	0.37[9.40]	0.81 (0.63) [20.57] (16.00)	0.22[5.59]	0.10[2.54]	0.19[4.83]
4	0.16[4.06]	0.37[9.40]	0.88 (0.63) [22.35] (16.00)	0.22[5.59]	0.10[2.54]	0.19[4.83]
5	0.16[4.06]	0.37[9.40]	0.88 (0.63) [22.35] (16.00)	0.22[5.59]	0.10[2.54]	0.19[4.83]
6	0.18[4.57]	0.37 [9.40]	0.88 (0.63) [22.35] (16.00)	0.22[5.59]	0.10[2.54]	0.19[4.83]
8	0.19[4.83]	0.44[11.26]	1.19 (1.06) [30.23] (26.92)	0.38[9.65]	0.15[3.81]	0.22[5.59]
10	0.27[6.86]	0.53[13.46]	1.19 (1.06) [30.23] (26.92)	0.38[9.65]	0.15[3.81]	0.22[5.59]
12	0.27[6.86]	0.53[13.46]	1.44 (1.31) [36.58] (33.27)	0.47[11.94]	0.15[3.81]	0.22[5.59]
15	0.30[7.62]	0.58[14.73]	1.44 (1.31)[36.58] (33.27)	0.47[11.94]	0.15[3.81]	0.22[5.59]

<sup>A</sup> Nominal inside diameter.

\* Indicates this item is made in extra heavy.

<sup>B</sup> For tolerances, see Table 2.

<sup>C</sup> Hub ends and spigot ends can be made with or without draft.

<sup>D</sup> Hub ends and spigot ends shall be permitted to be made with or without draft.

O Indicates this item is made in service weight.

### SUPPLEMENTARY REQUIREMENTS

The following supplementary requirements shall be applied only when specified by the purchaser. Details of the supplementary requirements shall be agreed upon by the manufacturer and the purchaser. The specified tests shall be performed by the manufacturer prior to shipment of the castings.

#### S1. Leak Tests on Pipe

S1.1 Sample lengths of pipe shall be checked for leaks by subjecting them to an internal hydrostatic pressure of 20 psi (138 kpa).

S1.2 Samples shall be taken at substantially regular intervals in the course of production so as to be representative of the

material delivered, and shall consist of at least 20 % of the lengths ordered in each size. For every sample which leaks, four or more additional samples shall be taken. Each additional sample shall be representative of the same material as that of the defective sample.

S1.3 Pipe which leak shall be rejected.

<https://standards.iteh.ai/catalog/standards/sist/6a406d07-bdf0-4ae4-9a90-973fa3e1415/astm-a74-98>

**ASTM A 74**

**TABLE 2 Dimensional Tolerances for Extra-Heavy and Service Cast Iron Soil Pipe and Fittings, in.**

NOTE 1—1 in. = 25.4 mm.

NOTE 2—The tolerances set forth in Table 2 are intended for pipe and fittings designed for use with lead and oakum joints; however, these same tolerances shall apply to pipe and fittings designed for use with a compression type gasket joint.

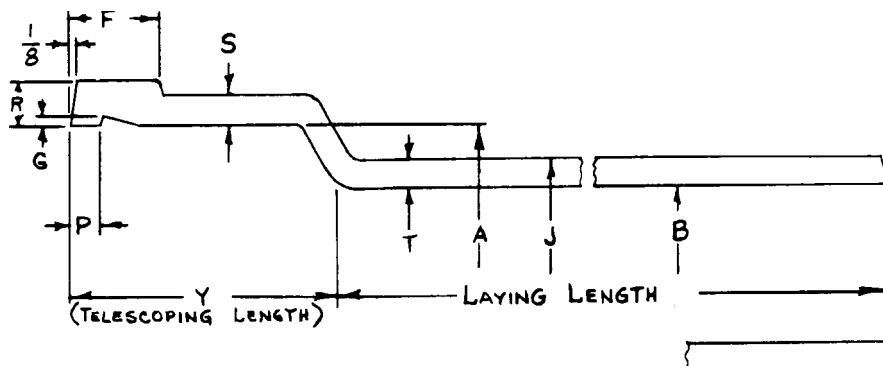

Size <sup>A</sup>	Outside Diameter of Barrel	Inside Diameter of Barrel	Tele-scoping Length	Laying Length			
	A'	J	B	Y	Pipe, 2½-, 3½-, 5-ft Lengths	Pipe, 10-ft Lengths	Fittings Regular      Extra Long <sup>B</sup>
2	±0.06 [1.52]	±0.09[±2.29]	±0.09[±2.29]	±0.06[±1.52]	±¼ [±6.35]	±½ [±12.7]	±⅛ [±3.18]      ±⅛ [±1.59]
3	±0.09[2.29]	±0.09[±2.29]	±0.06[±1.52]	±¼ [±6.35]	±½ [±12.7]	...	±⅛ [±1.59]
4	+0.09[2.29]	±0.09[±2.29]	±0.09[±2.29]	±0.06[±1.52]	±¼ [±6.35]	±½ [±12.7]	±⅛ [±3.18]      ±⅛ [±1.59]
5	+0.09[2.29]	±0.09[±2.29]	±0.09[±2.29]	±0.06[±1.52]	±⅕ [±7.94]	±⅝ [±15.88]	±⅜ [±4.76]      ±⅜ [±2.38]
6	-0.06 [1.52]	±0.09[±2.29]	±0.09[±2.29]	±0.06[±1.52]	±⅕ [±7.94]	±⅝ [±15.88]	±⅜ [±4.76]      ±⅜ [±2.38]
8	±0.13[3.30]	±0.13[±3.30]	±0.13[±3.30]	±0.13[±3.30]	±⅕ [±7.94]	±⅝ [±15.88]	±⅜ [±4.76]      ±⅜ [±2.38]
10	±0.13[3.30]	±0.13[±3.30]	±0.13[±3.30]	±0.13[±3.30]	±⅜ [±9.53]	±¾ [±19.05]	±¼ [±6.35]      ±⅛ [±3.18]
12	±0.13[3.30]	±0.19[±4.83]	±0.19[±4.83]	±0.19[±4.83]	±⅜ [±9.53]	±¾ [±19.05]	±¼ [±6.35]      ±⅛ [±3.18]
15	±0.13[3.30]	±0.19[±4.83]	±0.19[±4.83]	±0.19[±4.83]	±⅜ [±9.53]	±¾ [±19.05]	±¼ [±6.35]      ±⅛ [±3.18]
		Size			Distance from Lead Groove to End, Pipe and Fittings		
					P		
		2			±0.09 [±1.52]		
		3			±0.09 [±1.52]		
		4			±0.09 [±1.52]		
		5			±0.09 [±1.52]		
		6			±0.09 [±1.52]		
		8			±0.09 [±1.52]		
		10			±0.09 [±1.52]		
		12			±0.11 [±2.79]		
		15			±0.11 [±2.79]		

<sup>A</sup> Nominal inside diameter.

<sup>B</sup> These tolerances apply to each foot of extra-long fittings in excess of regular laying lengths specified herein.

**ASTM A 74**

**TABLE 3 Dimensions of One-Quarter Bends**

NOTE 1—1 in. = 25.4 mm.

NOTE 2—Dimensions *D* and *X* are laying lengths.

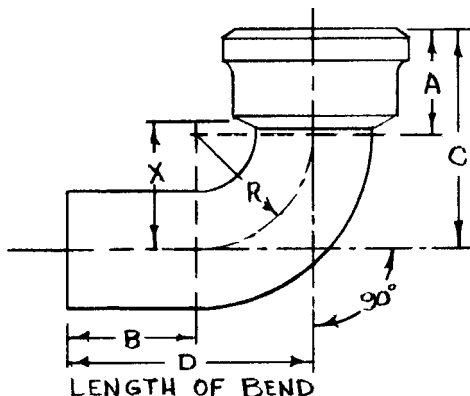

Size, in., Availability <sup>A</sup>	Dimensions in in. <sup>B</sup>					
	A	B	C	D	R	X
2"O	2¾ [70]	3 [76]	5¾ [146]	6 [152]	3 [76]	3¼ [83]
3"O	3¼ [83]	3½ [89]	6¾ [171]	7 [178]	3½ [89]	4 [102]
4"O	3½ [89]	4 [102]	7½ [191]	8 [203]	4 [102]	4½ [114]
5"O	3½ [89]	4 [102]	8 [203]	8½ [216]	4½ [114]	5 [127]
6"O	3½ [89]	4 [102]	8½ [216]	9 [229]	5 [127]	5½ [140]
8"O	4⅞ [105]	5½ [140]	10⅞ [257]	11½ [292]	6 [152]	6⅞ [168]
10"O	4⅞ [105]	5½ [140]	11⅞ [283]	12½ [318]	7 [178]	7⅞ [194]
12"O	5 [127]	7 [178]	13 [330]	15 [381]	8 [203]	8¾ [222]
15"O	5 [127]	7 [178]	14½ [368]	16½ [419]	9½ [241]	10¼ [260]

<sup>A</sup> \* indicates this item is made in extra heavy.

O indicates this item is made in service weight.

<sup>B</sup> For details of hubs and spigots, see Table 1.

Document Preview

ASTMA74-98

<https://standards.itech.ai/catalog/standards/sist/6a406d07-bdf0-4ae4-9a90-973faf3e1415/astm-a74-98>



**ASTM A 74**

**TABLE 4 Dimensions of Long One-Quarter Bends**

NOTE 1—1 in. = 25.4 mm.

NOTE 2—Dimensions *D* and *X* are laying lengths.

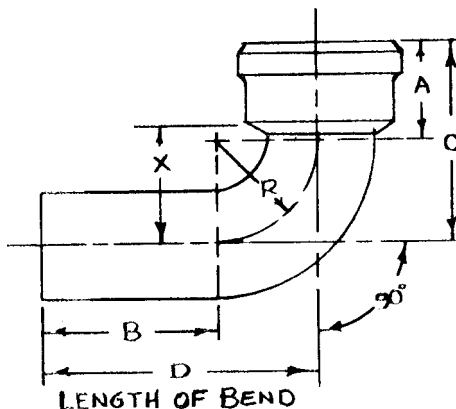

Size, in., Availability <sup>A</sup>	Dimensions in in. <sup>B</sup>					
	A	B	C	D	R	X
2 by 12°O	2¾ [76]	9 [229]	5¾ [146]	12 [305]	3 [76]	3¼[83]
2 by 18°O	2¾ [76]	15 [381]	5¾ [146]	18 [457]	3 [76]	3¼[83]
2 by 24°O	2¾ [76]	21 [533]	5¾ [146]	24 [610]	3 [76]	3¼[83]
3 by 12°O	3¼ [83]	8½[216]	6¾ [171]	12 [305]	3½[89]	4 [102]
3 by 18°O	3¼ [83]	14½[368]	6¾ [171]	18 [457]	3½[89]	4 [102]
3 by 24°O	3¼ [83]	20½[521]	6¾ [171]	24 [610]	3½[89]	4 [102]
4 by 12°O	3½ [89]	8 [203]	7½ [191]	12 [305]	4 [102]	4½[114]
4 by 18°O	3½ [89]	14 [356]	7½ [191]	18 [457]	4 [102]	4½[114]
4 by 24°O	3½ [89]	20 [508]	7½ [191]	24 [610]	4 [102]	4½[114]

<sup>A</sup> \* indicates this item is made in extra heavy.

O indicates this item is made in service weight.

<sup>B</sup> For details of hubs and spigots, see Table 1.

**TABLE 5 Dimensions of Long Low-Hub One-Quarter Bends**

NOTE 1—1 in. = 25.4 mm.

NOTE 2—Dimensions *D* and *X* are laying lengths.

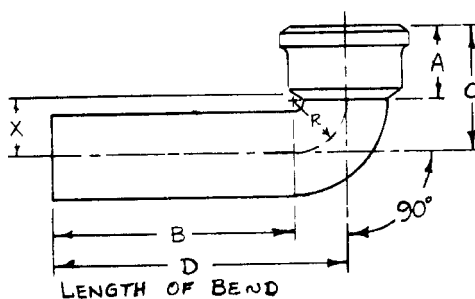

Size, in., Availability <sup>A</sup>	Dimensions in in. <sup>B</sup>					
	A	B	C	D	R	X
4 by 12O	3 [76]	9¼ [235]	5¾ [146]	12 [305]	2¾ [70]	2¾ [70]
4 by 14O	3 [76]	11¼ [286]	5¾ [146]	14 [356]	2¾ [70]	2¾ [70]
4 by 16O	3 [76]	13¼ [337]	5¾ [146]	16 [406]	2¾ [70]	2¾ [70]
4 by 18O	3 [76]	15¼ [387]	5¾ [146]	18 [457]	2¾ [70]	2¾ [70]

<sup>A</sup> O indicates this item is made in service weight.

<sup>B</sup> For details of hubs and spigots, see Table 1.

**ASTM A 74**

**TABLE 6 Dimensions of One-Quarter Bends with Low Heel Inlet**

NOTE 1—1 in. = 25.4 mm.

NOTE 2—Dimensions *D*, *X*, and *X'* are laying lengths

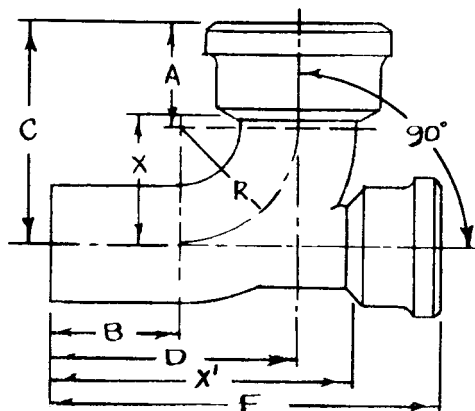

Size, in., Availability <sup>A</sup>	Dimensions in in. <sup>B</sup>									
A	B	C	D	F	R	X	X'			
3 by 2O	3¼ [83]	3½ [89]	6¾ [172]	7 [178]	11½ [292]	3½ [89]	4 [102]	9 [229]		
4 by 2°O	3½ [89]	4 [102]	7½ [191]	8 [203]	13 [330]	4 [102]	4½ [114]	10½ [267]		
4 by 3°O	3½ [89]	4 [102]	7½ [191]	8 [203]	13¼ [337]	4 [102]	4½ [114]	10½ [267]		

<sup>A</sup> \* indicates this item is made in extra heavy.

O indicates this item is made in service weight.

<sup>B</sup> For details of hubs and spigots, see Table 1.

iTeh Standards

(<https://standards.itih.ai>)

Document Preview

**TABLE 7 Dimensions of High Heel One-Quarter Bends**

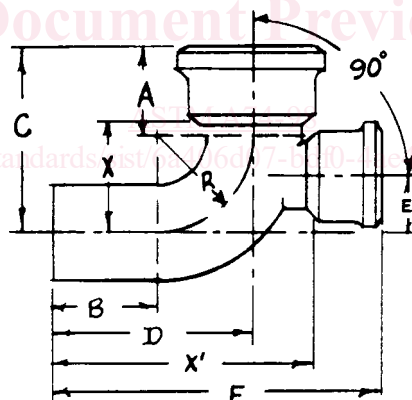

Size, in., Availability <sup>A</sup>	Dimensions in in. <sup>B</sup>									
A	B	C	D	E	F	R	X	X'		
3 by 2°O	3¼ [83]	3½ [89]	6¾ [171]	7 [178]	2¼ [57]	11½ [292]	3½ [89]	4 [102]	9 [229]	
4 by 2°O	3½ [89]	4 [102]	7½ [191]	8 [203]	2¾ [70]	13 [330]	4 [102]	4½ [114]	10½ [267]	
4 by 3°O	3½ [89]	4 [102]	7½ [191]	8 [203]	2¼ [70]	13¼ [337]	4 [102]	4½ [114]	10½ [267]	

<sup>A</sup> \* indicates this item is made in extra heavy.

O indicates this item is made in service weight.

<sup>B</sup> For details of hubs and spigots, see Table 1.



**TABLE 8 Dimensions of Short and Long Sweep Bends**

NOTE 1—1 in. = 25.4 mm.

NOTE 2—Dimensions *D* and *X* are laying lengths.

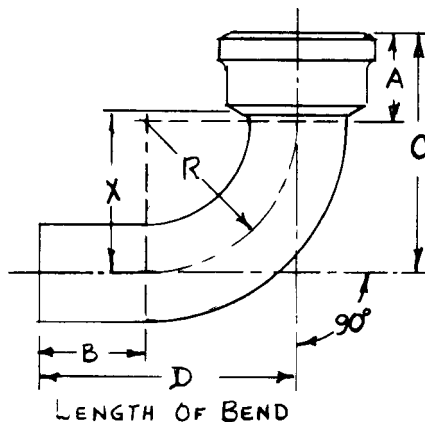

**Short Sweep Bends:**

Size, in.	Dimensions in in. <sup>A</sup>					
	A	B	C	D	R	X
2°O	2¾ [70]	3 [76]	7¾ [197]	8 [203]	5 [127]	5¼ [133]
3°O	3¼ [83]	3½ [89]	8¾ [222]	9 [229]	5½ [140]	6 [152]
4°O	3½ [89]	4 [102]	9½ [241]	10 [254]	6 [152]	6½ [165]
5°O	3½ [89]	4 [102]	10 [254]	10½ [267]	6½ [165]	7 [178]
6°O	3½ [89]	4 [102]	10½ [267]	11 [279]	7 [178]	7½ [191]
8°O	4⅞ [105]	5½ [140]	12⅞ [308]	13½ [343]	8 [203]	8¾ [219]
10°O	4⅞ [105]	5½ [140]	13⅞ [333]	14½ [368]	9 [229]	9¾ [244]
12°O	5 [127]	7 [178]	15 [381]	17 [432]	10 [254]	10¾ [273]
15°O	5 [127]	7 [178]	16½ [419]	18½ [470]	11½ [292]	12¼ [311]

<sup>A</sup>For details of hubs and spigots, see Table 1.

**Long Sweep Bends:**

Size, in., Availability <sup>A</sup>	Dimensions in in. <sup>B</sup>					
	A	B	C	D	R	X
2°O	2¾ [70]	3 [76]	10¾ [273]	11 [279]	8 [203]	8¼ [210]
3°O	3¼ [83]	3½ [89]	11¾ [298]	12 [305]	8½ [216]	9 [229]
4°O	3½ [89]	4 [102]	12½ [318]	13 [330]	9 [229]	9½ [241]
5°O	3½ [89]	4 [102]	13 [330]	13½ [343]	9½ [241]	10 [254]
6°O	3½ [89]	4 [102]	13½ [343]	14 [356]	10 [254]	10½ [267]
8°O	4⅞ [105]	5½ [140]	15⅞ [384]	16½ [419]	11 [279]	11¾ [295]
10°O	4⅞ [105]	5½ [140]	16⅞ [410]	17½ [445]	12 [305]	12¾ [321]
12°O	5 [127]	7 [178]	18 [457]	20 [508]	13 [330]	13¾ [349]
15O	5 [127]	7 [178]	19½ [495]	21½ [546]	14½ [368]	15¼ [387]

<sup>A</sup>\* indicates this item is made in extra heavy.

O indicates this item is made in service weight.

<sup>B</sup> For details of hubs and spigots, see Table 1.

**ASTM A 74**

**TABLE 9 Dimensions of Reducing Long Sweep Bends**

NOTE 1—1 in. = 25.4 mm.

NOTE 2—Dimensions *D* and *X* are laying lengths.

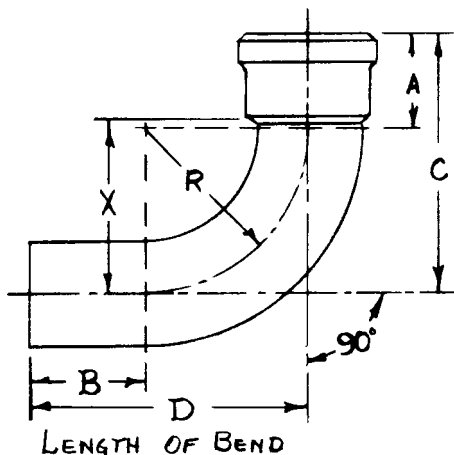

Size, in., Availability <sup>A</sup>	Dimensions in in. <sup>B</sup>					
	A	B	C	D	R	X
3 by 2"O	3 [76]	3½ [89]	11½ [292]	12 [305]	8½ [216]	9 [229]
4 by 3"O	3¼ [83]	4 [102]	12¼ [311]	13 [330]	9 [229]	9½ [241]

<sup>A</sup> \* indicates this item is made in extra heavy.

O indicates this item is made in service weight.

<sup>B</sup> For details of hubs and spigots, see Table 1.

iTeh Standards  
(<https://standards.itih.ai>)  
Document Preview

ASTM A74-98

<https://standards.itih.ai/catalog/standards/sist/6a406d07-bdf0-4ae4-9a90-973faf3e1415/astm-a74-98>