International Standard



7946

INTERNATIONAL ORGANIZATION FOR STANDARDIZATION • МЕЖДУНАРОДНАЯ ОРГАНИЗАЦИЯ ПО СТАНДАРТИЗАЦИИ • ORGANISATION INTERNATIONALE DE NORMALISATION

Woodworking machines — Slot mortising machines — Nomenclature and acceptance conditions

Machines à bois — Mortaiseuses à mèche simples — Nomenclature et conditions de réception

First edition — 1985-06-15 **ITeH STANDARD PREVIEW**
(standards.iteh.ai)

[ISO 7946:1985](https://standards.iteh.ai/catalog/standards/sist/30005997-8319-492b-ad54-b476ce18ea6d/iso-7946-1985)

<https://standards.iteh.ai/catalog/standards/sist/30005997-8319-492b-ad54-b476ce18ea6d/iso-7946-1985>

UDC 674.05 : 621.952

Ref. No. ISO 7946-1985 (E)

Descriptors : machine tools, woodworking machinery, slotting machines, nomenclature, tests, measurement, accuracy.

Foreword

ISO (the International Organization for Standardization) is a worldwide federation of national standards bodies (ISO member bodies). The work of preparing International Standards is normally carried out through ISO technical committees. Each member body interested in a subject for which a technical committee has been established has the right to be represented on that committee. International organizations, governmental and non-governmental, in liaison with ISO, also take part in the work.

Draft International Standards adopted by the technical committees are circulated to the member bodies for approval before their acceptance as International Standards by the ISO Council. They are approved in accordance with ISO procedures requiring at least 75 % approval by the member bodies voting.

International Standard ISO 7946 was prepared by Technical Committee ISO/TC 39, *Machine tools*.

[ISO 7946:1985](https://standards.iteh.ai/catalog/standards/sist/30005997-8319-492b-ad54-b476ce18ea6d/iso-7946-1985)

<https://standards.iteh.ai/catalog/standards/sist/30005997-8319-492b-ad54-b476ce18ea6d/iso-7946-1985>

Woodworking machines – Slot mortising machines – Nomenclature and acceptance conditions

iTeh STANDARD PREVIEW (standards.iteh.ai)

1 Scope and field of application

This International Standard specifies the nomenclature appropriate to each part of the machine and, with reference to ISO/R 230, the geometrical tests for slot mortising machines, and gives the corresponding permissible deviations which apply to machines for general purpose use and normal accuracy.

NOTE — In addition to terms used in two of the three official ISO languages (English and French), this International Standard gives in the annex the equivalent terms in German, Spanish, Italian and Swedish; these have been included at the request of Technical Committee ISO/TC 39 and are published under the responsibility of the member bodies for Germany, F.R. (DIN), Spain (IRANOR), Italy (UNI) and Sweden (SIS). However, only the terms and definitions given in the official languages can be considered as ISO terms and definitions.

This International Standard deals only with the verification of accuracy of the machine. It does not apply to the testing of the running of the machine (vibrations, abnormal noises, stick-slip motion of the components, etc.), nor to its characteristics (speeds, feeds, etc.) which should generally be checked before testing accuracy.

This International Standard does not impose any practical test. For slot mortising machines, practical tests should be exceptions and have to be stated in a previous agreement between the producer and the user.

2 Reference

ISO/R 230, *Test code for machine tools*.

3 Preliminary remarks

3.1 In this International Standard all dimensions and permissible deviations are expressed in millimetres.

3.2 To apply this International Standard, reference should be made to ISO/R 230, especially for installation of the machine before testing, the warming up of the main spindle and other moving parts, and description of measuring methods. The measuring instruments shall not permit errors over 1/3 of the checked tolerances.

3.3 The sequence in which the geometrical tests are given is related to the sub-assemblies of the machine and this in no way defines the practical order of testing. In order to make mounting of instruments or gauging easier, tests may be applied in any order.

3.4 When inspecting a machine, it is not always possible or necessary to carry out all the tests given in this International Standard.

3.5 It is up to the user to choose, in agreement with the manufacturer, those tests relating to the properties which are of interest to him, but these tests are to be clearly stated when ordering a machine.

3.6 A movement is longitudinal when it takes place in the working direction of the piece.

3.7 When establishing the tolerance for a measuring range different from that given in this International Standard (see 2.311 in ISO/R 230), it should be taken into consideration that the minimum value of the tolerance is 0,01 mm.

4 Nomenclature

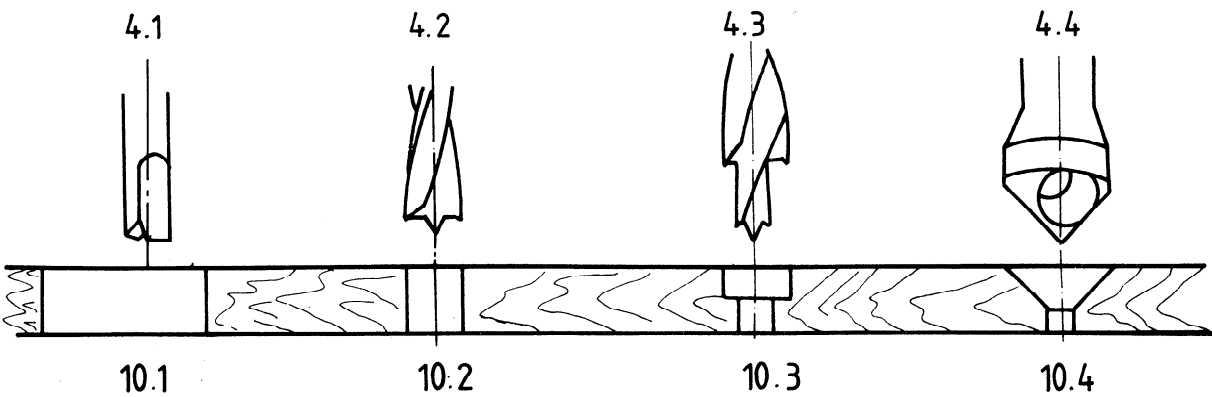
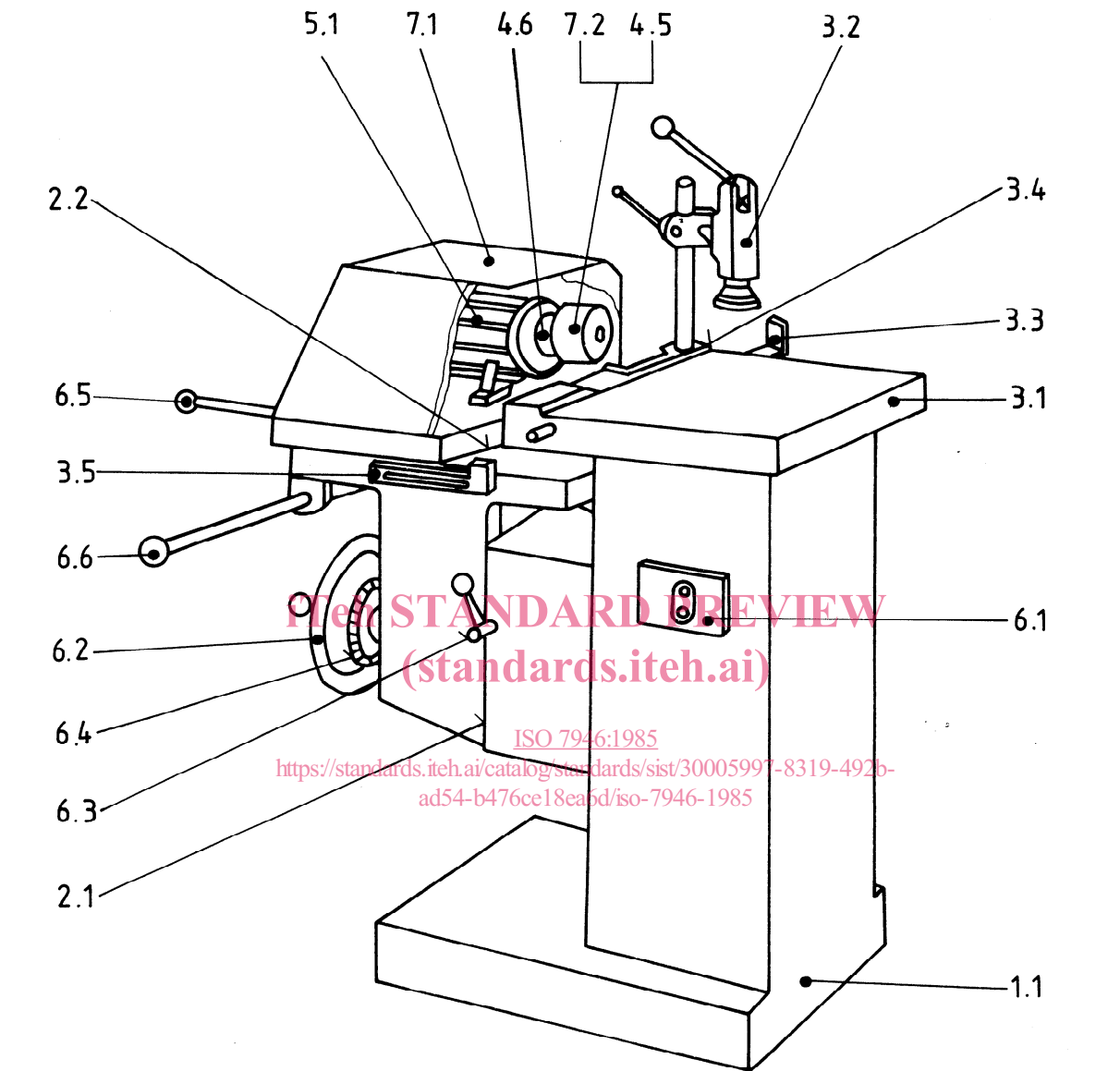

Reference	English	French
	Slot mortising machine	Mortaiseuse à mèche simple
1	Framework	Ossature
1.1	Main frame	Bâti
2	Feed of workpiece and/or tools	Déplacement des pièces et/ou outils
2.1	Vertical adjustment slide	Glissière de déplacement vertical de la tête porte-outils
2.2	Infeed slide	Glissière de déplacement horizontal de la tête porte-outils
3	Workpiece support clamp and guide	Support, maintien et guidage des pièces
3.1	Table	Table
3.2	Workpiece clamp	Presseur
3.3	End stop	Guide latéral
3.4	Front fence	Guide longitudinal
3.5	Depth stop	Butée de profondeur de mortaise
4	Toolholders and tools	Porte-outils et outils
4.1	Mortise bit	Outil de mortaisage
4.2	Boring bit	Outil de perçage
4.3	Counterbore	Mèche étagée
4.4	Countersink	Mèche conique
4.5	Chuck	Mandrin
4.6	Spindle	Broche
5	Workheads and tool drives	Unité de travail et son entraînement
5.1	Cutterhead motor	Moteur
6	Controls	Commandes
6.1	Stop/start switch	Commutateur
6.2	Handwheel for vertical adjustment	Commande de réglage vertical du porte-outils
6.3	Vertical adjustment lock	Commande de verrouillage du réglage vertical du porte-outils
6.4	Vertical adjustment scale	Règle graduée du réglage vertical du porte-outils
6.5	Cross traverse lever	Levier de course transversale
6.6	Infeed lever	Levier de pénétration
7	Safety devices (examples)	Dispositifs de sécurité (exemples)
7.1	Cutterhead guard	Capot du moteur
7.2	Chuck guard	Protecteur de mandrin
8	Miscellaneous	Divers
9	Free	Libre
10	Examples of work	Exemples de travail
10.1	Slot mortising	Mortaisage
10.2	Boring	Perçage
10.3	Counter boring	Perçage étagé
10.4	Counter sinking	Perçage conique

5 Acceptance conditions and permissible deviations — Geometrical tests

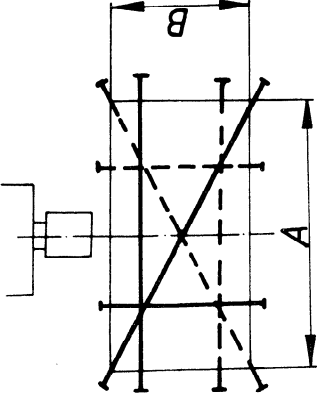
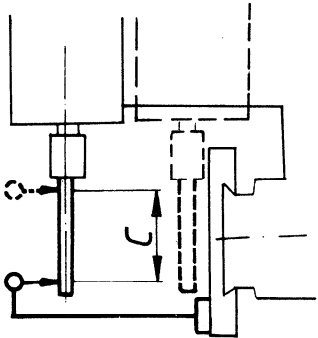
No.	Diagram	Object	Permissible deviation	Measuring instruments	Observations and references in test code ISO/R 230
G1	 <p data-bbox="644 1615 703 1845">A = length of the table B = width of the table</p>	<p data-bbox="368 1122 421 1406">Checking of flatness of the table :</p> <p data-bbox="456 1240 509 1406">a) longitudinal straightness</p> <p data-bbox="544 1240 596 1406">b) transverse straightness</p> <p data-bbox="632 1137 684 1406">c) diagonal straightness</p>	<p data-bbox="272 904 293 1010">a) and c)</p> <p data-bbox="325 936 346 981">0,20</p> <p data-bbox="368 958 389 1093">for $A < 630$</p> <p data-bbox="421 927 442 972">0,40</p> <p data-bbox="469 958 489 1093">for $A > 630$</p> <p data-bbox="521 943 542 981">b)</p> <p data-bbox="572 927 593 972">0,10</p> <p data-bbox="620 958 641 1093">for $B < 200$</p> <p data-bbox="673 927 694 972">0,15</p> <p data-bbox="715 958 735 1093">for $B > 200$</p>	<p data-bbox="469 645 552 786">Straightedge and feeler gauges</p>	<p data-bbox="496 367 517 501">Clause 5.322</p>
G2		<p data-bbox="1070 1128 1182 1406">Checking of parallelism of the spindle axis (in the upper and lower position) to the table surface</p>	<p data-bbox="1091 927 1112 972">0,20</p> <p data-bbox="1139 958 1160 1093">for $C = 150$</p>	<p data-bbox="1098 622 1150 786">Dial gauge and test mandrel</p>	<p data-bbox="1109 353 1129 510">Clause 5.412.4</p>

Teh STANDARD PREVIEW
(standards.iteh.ai)

ISO 7946:1985

<https://standards.iteh.ai/catalog/standards/sist/30005997-8319-a44-b476ce18ea6d/iso-7946-1985>

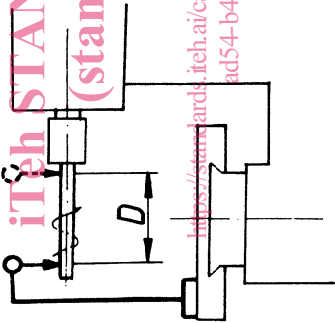
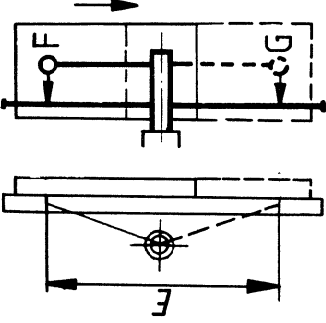
No.	Diagram	Object	Permissible deviation	Measuring instruments	Observations and references in test code ISO/R 230
G3	 <p data-bbox="336 1122 443 1653">iTech STANDARD PREVIEW (standards.itech.ai)</p> <p data-bbox="459 1122 571 1391">Measuring of run-out of spindle</p> <p data-bbox="480 1408 507 1529">ISO 7946:1985</p> <p data-bbox="512 1115 571 1787">https://standards.itech.ai/catalog/standards/sist/30005997-8319-492b-ad54-b476ce18ea6d/iso-7946-1985</p>	<p data-bbox="448 920 512 1081">0,30 for $D = 150$</p>	<p data-bbox="456 613 507 775">Dial gauge and test mandrel</p>	<p data-bbox="469 353 491 510">Clause 5.611.3</p>	<p data-bbox="150 293 201 573">Observations and references in test code ISO/R 230</p>
G4		<p data-bbox="1066 1128 1177 1391">Checking of squareness of the axis of the spindle to the table longitudinal motion</p>	<p data-bbox="1102 898 1129 1003">0,30/400*</p>	<p data-bbox="1066 636 1177 775">Dial gauge, square, test mandrel, and straightedge</p>	<p data-bbox="963 353 986 510">Clause 5.522.3</p> <p data-bbox="1018 293 1273 573">Place straightedge parallel to the relative motion of the table to the spindle, at the spindle level. Fix the dial gauge against the square stylus touching the straightedge. Note the reading and turn the spindle 180°.</p> <p data-bbox="1410 434 1433 573">* Distance E</p>

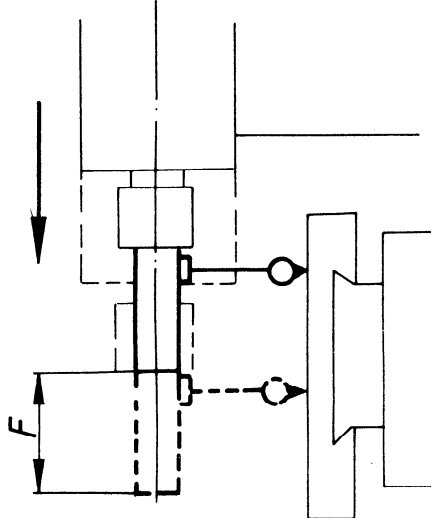
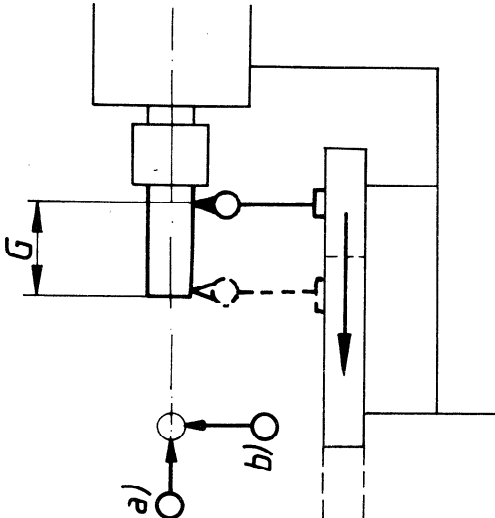
No.	Diagram	Object	Permissible deviation	Measuring instruments	Observations and references in test code ISO/R 230
G5		<p>Checking of parallelism of the spindle movement to the table surface</p> <p>ISO 7946:1985 https://standards.iteh.ai/catalog/standards/sist/30005997-8319-4911-ad54-b476ce18ea6d/iso-7946-1985</p>	<p>0,30 for $F = 150$</p>	<p>Dial gauge and test mandrel</p>	<p>Clause 5.422.2</p>
G6		<p>Checking of parallelism of the table transverse motion to the axis of the spindle in two directions <i>a)</i> and <i>b)</i></p>	<p><i>a)</i> and <i>b)</i> 0,30 for $G = 150$</p>	<p>Dial gauge and test mandrel</p>	<p>Clause 5.422.3</p>

Annex Equivalent terms

Reference	German	Spanish	Italian	Swedish
	Langlochfräsmaschine	Escopleadora de barrocha	Mortasatrice a punto	Långhålsborrmaskin
1	Ständer	Armadón	Intelaiatura	Stativkonstruktion
1.1	Gestell	Bastidor	Telaio	Stativ
2	Vorschub von Werkstück und/oder Werkzeug	Desplazamiento de las piezas y/o de las herramientas	Spostamento dei pezzi e/o degli utensili	Matning av arbetsstycke och/eller verktyg
2.1	Schlitzenführung zur Höhenverstellung des Fräsmotors	Guía de desplazamiento vertical del cabezal porta-herramienta	guida di spostamento verticale della testa portautensili	Verikalislid
2.2	Schlitzenführung zur Seitenverstellung des Fräsmotors	Guía de desplazamiento horizontal del cabezal porta-herramienta	Guida di spostamento orizzontale della testa portautensili	Slid för inmatningsrörelsen
3	Werkstückauflage, -Halterung und -Führung	SopORTE, sujeción y guía de las piezas	Supporto, fissaggio e guida dei pezzi	Styrning av arbetsstycke
3.1	Werkstückauflagetisch	Mesa	Tavola	Bord
3.2	Werkstückspanner	Prensore	Pressore	Fastspänningsanordning
3.3	Werkstückqueranschlag	Guía lateral	Guida laterale	Ändstopp
3.4	Werkstücklängsanschlag	Guía longitudinal	Guida longitudinale	Styrlinjal
3.5	Verstellbarer Anschlag für Frästiefe	Tope de profundidad de escopleado	Arresto di profondità di cava	Stopp för borddjup
4	Werkzeugträger und Werkzeug	Porta-herramienta y herramientas	Portautensili ed utensili	Verktygshållare och verktyg
4.1	Langlochfräser	Herramienta de escopleado	Utensile di mortasatura	Långhålsfräs
4.2	Bohrer	Herramienta de taladrado	Utensile di foratura	Borr
4.3	Stufenbohrer	Broca cónica	Punta a piani	Ansatsborr
4.4	Senker	Broca cónica	Punta conica	Försänkingsborr
4.5	Bohrfutter	Mandril	Mandrino	Chuck
4.6	Spindel	Husillo	Mandrino	Spindel
5	Einbauteile und Teile für den Werkzeugantrieb	Unidad de trabajo y su transmisión	Unità operatrice e suo azionamento	Bearbetningsenheter och drivsystem
5.1	Elektromotor	Motor	Motore	Motor
6	Bedienungs- und Überwachungsorgane	Mandos	Comandi	Manöverorgan
6.1	Elektrischer Schalter (Motorschutzschalter)	Commutador	Commutatore	Strömställare
6.2	Handrad für Höhenverstellung des Fräsmotors	Mando de reglaje vertical del porta-herramienta	Comando di regolazione verticale del portautensili	Ratt för vertikalrörelse
6.3	Feststeller für Höhenverstellung des Fräsmotors	Mando de bloqueaje del reglaje vertical del porta-herramienta	Leva di bloccaggio della regolazione verticale del portautensili	Låsning av vertikalrörelse
6.4	Skala für Höhenverstellung des Fräsmotors	Regla graduada del reglaje vertical del porta-herramienta	Scala graduata della regolazione verticale del portautensili	Skala för vertikalrörelse
6.5	Hebel für Frästiefe	Palanca de curso transversal	Leva di corsa trasversale	Spak för tvärmatning
6.6	Hebel für Fräslänge	Palanca de penetración	Scala di penetrazione	Spak för djupmatning
7	Sicherheitseinrichtungen (Beispiele)	Dispositivos de seguridad (ejemplos)	Dispositivi di sicurezza (esempi)	Säkerhetsanordningar (exempel)
7.1	Motorabdeckung	Cubierta del motor	Coperchio del motore	Motor kåpa
7.2	Schutzhülse für Bohrfutter	Protector del mandril	Protezione del mandrino	Skydd för chuck
8	Verschiedenes	Diversos	Varie	Diverse
9	Frei	Libre	Libero	Vakant
10	Arbeitsbeispiele	Ejemplos de trabajo	Esempi di lavorazione	Bearbetningsexempel
10.1	Langlochfräsen	Escopleado	Mortasatura	Långhålsborrning
10.2	Bohren	Taladrado	Foratura	Borrning
10.3	Stufenbohren	Taladrado escalonado	Foratura a piani	Planförsänkning
10.4	Senken	Taladrado cónico	Foratura conica	Försänkning