International Standard



7965/1

INTERNATIONAL ORGANIZATION FOR STANDARDIZATION • МЕЖДУНАРОДНАЯ ОРГАНИЗАЦИЯ ПО СТАНДАРТИЗАЦИИ • ORGANISATION INTERNATIONALE DE NORMALISATION

Packaging — Sacks — Drop test — Part 1: Paper sacks

Emballages — Sacs — Essai de chute — Partie 1: Sacs en papier

First edition — 1984-12-15

ITeH STANDARD PREVIEW
(standards.iteh.ai)

[ISO 7965-1:1984](https://standards.iteh.ai/catalog/standards/sist/dcd158d4-169d-482e-9155-643cbcbf819a/iso-7965-1-1984)

<https://standards.iteh.ai/catalog/standards/sist/dcd158d4-169d-482e-9155-643cbcbf819a/iso-7965-1-1984>

UDC 621.798.15 : 676.821 : 620.165.72

Ref. No. ISO 7965/1-1984 (E)

Descriptors : packing, paper packaging, bags, tests, drop tests, test equipment.

Foreword

ISO (the International Organization for Standardization) is a worldwide federation of national standards bodies (ISO member bodies). The work of preparing International Standards is normally carried out through ISO technical committees. Each member body interested in a subject for which a technical committee has been established has the right to be represented on that committee. International organizations, governmental and non-governmental, in liaison with ISO, also take part in the work.

Draft International Standards adopted by the technical committees are circulated to the member bodies for approval before their acceptance as International Standards by the ISO Council. They are approved in accordance with ISO procedures requiring at least 75 % approval by the member bodies voting.

International Standard ISO 7965/1 was prepared by Technical Committee ISO/TC 122, *Packaging*.

ITEH STANDARD PREVIEW
(standards.iteh.ai)

<https://standards.iteh.ai/catalog/standards/sist/dcd158d4-169d-482e-9155-643cbcbf819a/iso-7965-1-1984>

Packaging — Sacks — Drop test — Part 1: Paper sacks

1 Scope and field of application

This part of ISO 7965 specifies a method of vertical impact testing on a filled paper sack by dropping. It may be performed either as a single test to investigate the effects of vertical impact or as part of a sequence of tests designed to measure the ability of a sack to withstand a distribution system that includes a vertical impact hazard.

This part of ISO 7965 specifies the testing procedure and how the results of tests should be presented. It is based on ISO 2248, but is specifically related to paper sacks.

2 References

ISO 2248, *Packaging — Complete, filled transport packages — Part 4: Vertical impact test by dropping.*

ISO 6599/1, *Packaging — Sacks — Conditioning for testing — Part 1: Paper sacks.*

ISO 7023, *Packaging — Sacks — Method of sampling empty sacks for testing.*

3 Principle

The filled sack is raised above a rigid plane surface and released to strike this surface after a free fall, the atmospheric conditions, the height of drop and the position of the package being set in advance.

4 Apparatus

The apparatus necessary to carry out the drop test shall include the following (examples are shown in annex A):

4.1 lifting arrangement, which will not damage the sack during either lifting or release.

4.2 means of holding the sack prior to release in its predetermined position.¹⁾

4.3 release mechanism, to release the sack in such a way that its fall is not obstructed by any part of the apparatus before striking the impact surface (4.4).

4.4 impact surface, horizontal and flat, massive enough to be immovable and rigid enough to be non-deformable under test conditions.

NOTE — In normal circumstances the impact surface provided should be:

- of one piece, with a mass at least 50 times that of the heaviest sack to be tested;
- flat, such that no two points on its surface differ in level by more than 2 mm;
- rigid, such that it will not be deformed by more than 0,1 mm when an area of 100 mm² is loaded statically with 10 kg anywhere on the surface;

sufficiently large to ensure that the sack falls entirely upon the surface.

A plastic film may be used on the impact surface under the sack in order not to damage the sack while moving it.

5 Sampling

Sampling shall be carried out in accordance with the procedure in ISO 7023.

6 Conditioning

The empty sacks shall be conditioned in accordance with the procedure in ISO 6599/1, using one of the designated conditioning atmospheres.

7 Procedure

The various tests as described shall be carried out in the same atmospheric conditions as used for conditioning (see clause 6) or, if not, the tests shall commence within 3 min of removing the sack from the conditioning atmosphere.

1) The difference in behaviour of a sack suspended from the top or supported underneath in a butt drop can be significant, and the method of holding the sack before dropping must be included in the test report.

7.1 Filling

Fill the sacks with the intended commodity but, if this is not possible, with similar material, taking into account type and size of granules etc., to give the same degree of filling. The mass of filling material shall be within $\pm 0,2\%$ of that of the nominal mass of the intended contents of the sack.

Position the sack on the trap door of the apparatus before the drop.

7.2 Dropping

Place the sack under test centrally on the platform which is then raised to a height that is within $\pm 2\%$ of the predetermined drop height as defined by the distance between the lowest point of the sack at the time of release and the nearest point of the impact surface.

The sack shall be released from its predetermined position within the following tolerances:

- for drops on any side or edge: there shall be no variation of more than 2° between the impacting surface of the sack, and the horizontal surface;
- for edge or corner drops: the angle between a prescribed surface of the sack and the horizontal surface shall be $45 \pm 5^\circ$;
- the velocity at impact shall be within $\pm 1\%$ of that which would be achieved by a free fall.

7.2.1 Dropping procedure

NOTE — The designation of the various surfaces of the filled sack is set down in annex B.

7.2.1.1 Flat dropping

Drop successive sacks alternately on the face side (1) and on the back side (3), so that the first sack is dropped on the face side until it breaks and the second on the back side until it breaks, and so on.

7.2.1.2 Side dropping

Drop successive sacks alternately on the side (2) and the side (4), so that the first sack is dropped on the side (2) until it breaks and the second on the side (4) until it breaks, and so on.

7.2.1.3 Butt dropping

Drop the sack only on the bottom (5), until it breaks.

7.2.1.4 Edge and corner dropping

If this test is necessary, drop the sack on any corner or any edge until it breaks.

7.3 Test methods

7.3.1 Progressive drop height method

This method may be used for flat, side and butt drop testing of paper sacks.

7.3.1.1 Flat and side drop test

The drop height, h , is given by the formula

$$h = 0,85 + [(n - 1) \times 0,15]$$

where

0,85 is the value, in metres, of the initial drop height (h_0);

n is the number of drops;

0,15 is the value, in metres, of the increment (Δh).

The drop test shall be initiated at 0,85 m height (h_0). After each drop without any visible failure on the sack, an increment of 0,15 m in drop height is made.

A sack shall be considered broken when spillage of the contents occurs.

The number of drops and the final drop height at break are recorded.

The test result can be reported as the average breaking height (h) and the corresponding number of drops (n).

7.3.1.2 Butt drop test

The drop height, h , is given by the formula

$$h = 0,30 + [(n - 1) \times 0,05]$$

where

0,30 is the value, in metres, of the initial drop height (h_0);

n is the number of drops;

0,05 is the value, in metres, of the increment (Δh).

The test result shall be reported in accordance with 7.3.1.1.

NOTE — For sacks of composite materials or with reinforcement of any type, a suitable initial drop height (h_0) may be selected with increments (Δh) of about 1/6 of the initial height, rounded to the nearest 0,15 m.

7.3.2 Constant drop height method

This method may be used for testing of ordinary paper sacks as an alternative to the progressive drop height method.

7.3.2.1 Flat, side or butt drop test

This test may be used for either flat, side or butt dropping and shall be performed from a constant height so selected that the number of drops before rupture is about 10.

A sack shall be considered broken when spillage of the content occurs.

The report shall give the drop height, number of drops to breakage and the type of drops (i.e., flat, side or butt drops).

NOTE — The constant drop height method has a special application when testing paper sacks intended for the transport of dangerous goods (maximum net mass 50 kg). According to Recommendations by the United Nations¹⁾ and the IMDG Code²⁾, three sacks shall be sampled and tested. In the UN Recommendations, paper sacks intended to convey goods presenting medium danger (Packaging Group II) shall be dropped from a height of 1,2 m while those presenting minor danger (Packaging Group III) shall be dropped from a height of 0,8 m. It is required that each of the filled sacks shall be dropped once on the face side and once on the bottom from the prescribed height. With both levels of testing, there shall be neither serious rupture of any of the sacks nor loss of contents.

7.3.3 Limit height method

This method shall be used to test sacks with higher strength than ordinary paper sacks.

7.3.3.1 Flat, side or butt drop test

The test may be performed as a flat, side or butt drop test.

In this test, the lowest height at which the sack will break on the first drop is calculated from the results obtained.

The sack shall be dropped from three constant heights, which give mean drop numbers (\bar{n}) of approximately 3, 8 and 13.

The limit height, H , is calculated from the formula:

$$\bar{n} = \left(\frac{H}{h}\right)^a$$

where

- \bar{n} is the mean drop number;
- H is the limit height, in metres;
- h is the drop height, in metres;
- a is the constant to one sack grade.

H may also be calculated using a graphical method, by plotting the mean drop number, \bar{n} , against the corresponding drop height, h , on log-log graph paper as shown in figure 1.

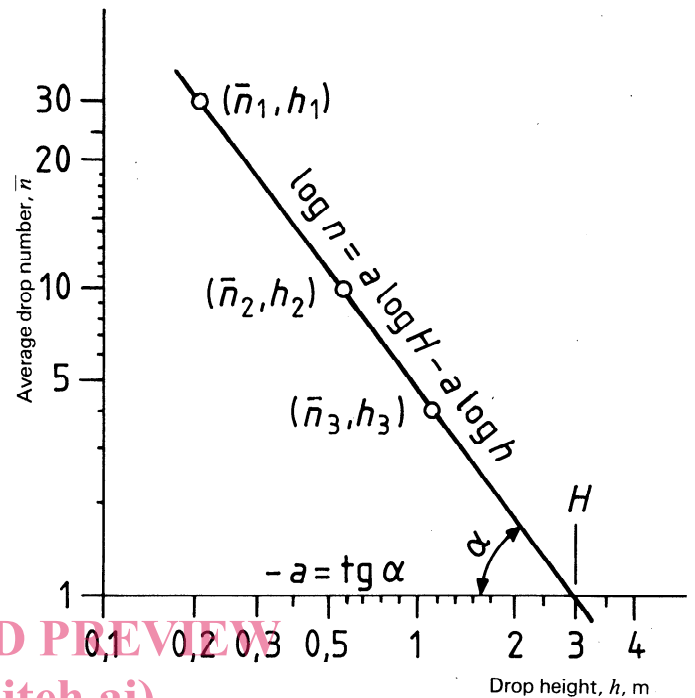

Figure 1 — Graphical method for calculation of limit height, H

The test report shall give the drop heights used, number of drops to breakage at each height and the type of drops (i.e., flat, side or butt).

8 Test report

The test report shall include full details of size, construction and type of all sacks tested, together with information on the type and weight of contents and type of closure.

All results shall be given and shall include details of position and type of failures.

A suitable format for a report form that may be used for this purpose is given in annex C.

1) *Transport of dangerous goods — Recommendations prepared by the United Nations Committee of Experts on the Transport of Dangerous Goods*, United Nations Economic and Social Council.

2) *International Maritime Dangerous Goods Code*, IMO (previously IMCO).

Annex A

Examples of apparatus for drop testing

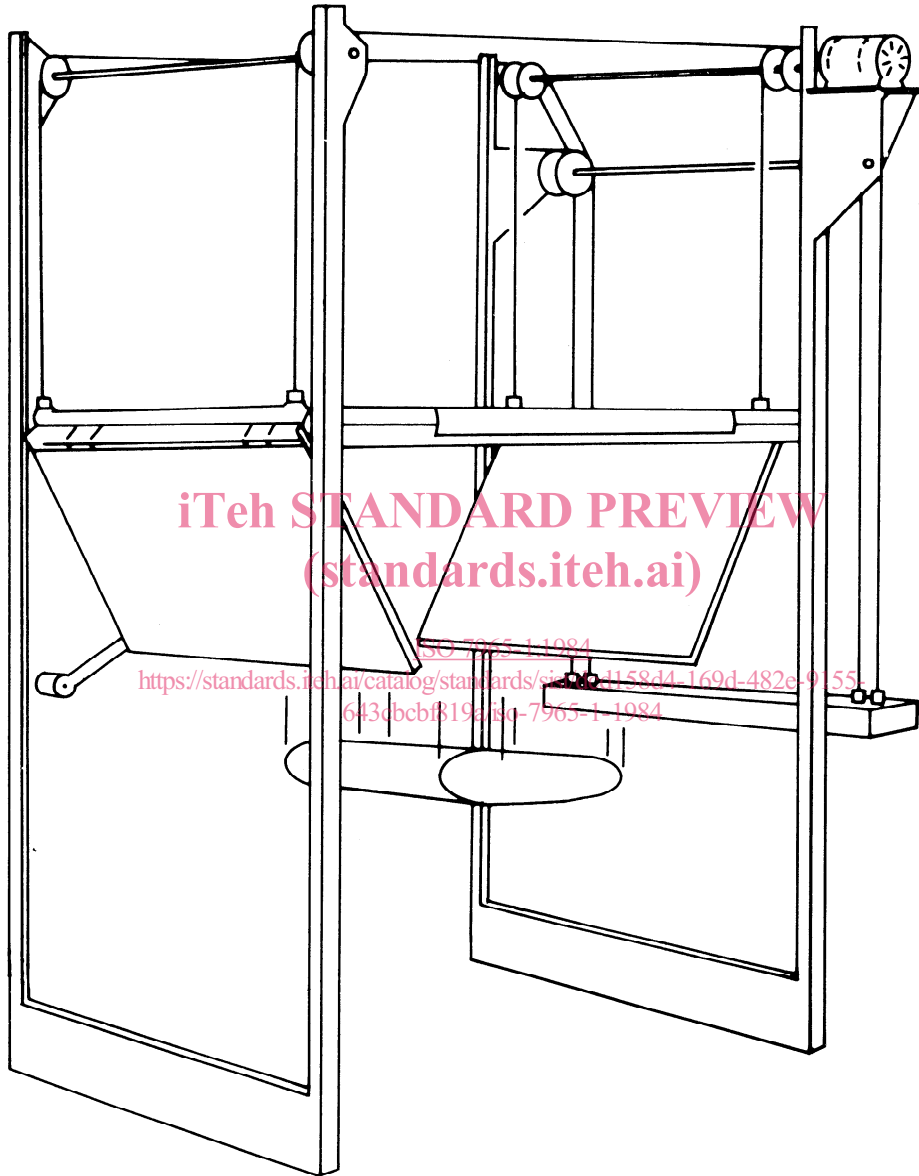

Figure 2 — Example of apparatus suitable for flat and side dropping

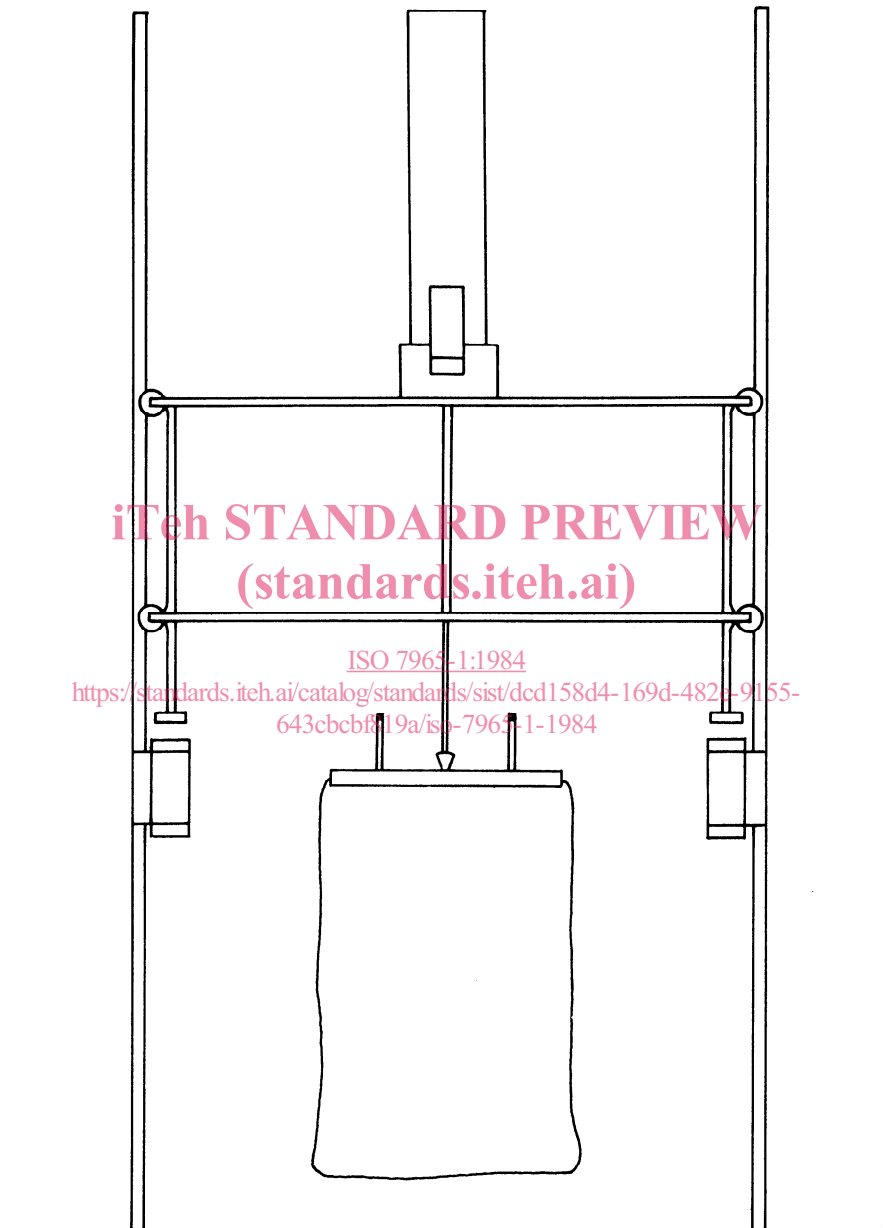

Figure 3 — Example of apparatus suitable for butt dropping

Annex B

Identification of surfaces of filled sacks for testing

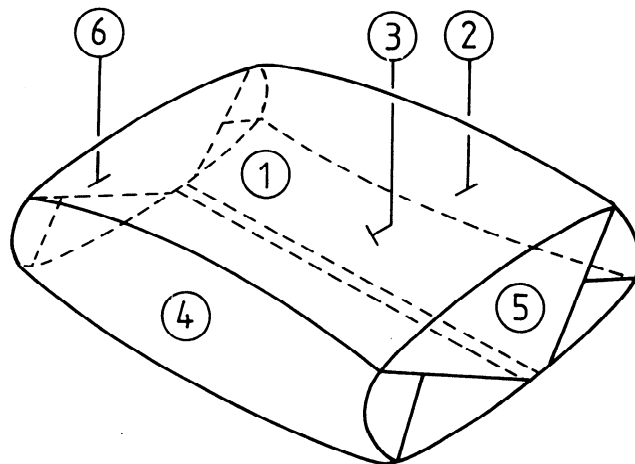

Figure 4 – Surface identification

The sack shall be placed on the back side (3) (i.e., the side containing the longitudinal seam) downwards, and the top (6) (i.e. the filling end) of the sack positioned away from the observer, as figure 4. The different surfaces are identified as:

- Surface 1: Face side
- Surface 2: Right side
- Surface 3: Back side (longitudinal seam)
- Surface 4: Left side
- Surface 5: Bottom
- Surface 6: Top (filling end)

<https://standards.iteh.ai/catalog/standards/sist/dcd158d4-169d-482e-9155-643cbcbf819a/iso-7965-1-1984>
 ISO 7965-1:1984

Annex C

Example of format for a drop test report

Test details

Manufacturer:	Sack type:	Test purpose:
Lot No.:	Dimensions:	Test method:
Date of manufacture:	Specifications:	Conditioning:
Order No.:		Filling material:
Customer:	Date of test:	Filling mass:

Test results

iTeh STANDARD PREVIEW

(standards.iteh.ai)

Drop No.	<i>h</i> cm	Sack No.														
		1	2	3	4	5	6	7	8	9	10	11	12	13	14	15
1																
2																
3																
4																
5																
6																
7																
8																
9																
10																
11																
12																
13																
14																
15																
16																
17																
18																
19																
20																

Remarks:

Date:

Signature: