



**SLOVENSKI STANDARD**  
**SIST ISO 7992:1998**  
**01-februar-1998**

---

Iron ores -- Determination of reduction properties under load

Iron ores -- Determination of reduction properties under load

Minerais de fer -- Détermination des propriétés de réduction sous charge

**Ta slovenski standard je istoveten z: ISO 7992:1992**

[SIST ISO 7992:1998](https://standards.iteh.ai/catalog/standards/sist/1824c570-9580-43c6-9a73-ff602eb929bb/sist-iso-7992-1998)

<https://standards.iteh.ai/catalog/standards/sist/1824c570-9580-43c6-9a73-ff602eb929bb/sist-iso-7992-1998>

**ICS:**

73.060.10      Železove rude      Iron ores

**SIST ISO 7992:1998**      en

**iTeh STANDARD PREVIEW**  
**(standards.iteh.ai)**

SIST ISO 7992:1998

<https://standards.iteh.ai/catalog/standards/sist/1824c570-9580-43c6-9a73-ff02eb929bb/sist-iso-7992-1998>

# INTERNATIONAL STANDARD

**ISO**  
**7992**

First edition  
1992-08-15

---

---

## Iron ores — Determination of reduction properties under load

**iTeh STANDARD PREVIEW**  
*Minerais de fer — Détermination des propriétés de réduction sous  
charge*  
**(standards.iteh.ai)**

SIST ISO 7992:1998

<https://standards.iteh.ai/catalog/standards/sist/1824c570-9580-43c6-9a73-ff602eb929bb/sist-iso-7992-1998>



Reference number  
ISO 7992:1992(E)

ISO 7992:1992(E)

## Foreword

ISO (the International Organization for Standardization) is a worldwide federation of national standards bodies (ISO member bodies). The work of preparing International Standards is normally carried out through ISO technical committees. Each member body interested in a subject for which a technical committee has been established has the right to be represented on that committee. International organizations, governmental and non-governmental, in liaison with ISO, also take part in the work. ISO collaborates closely with the International Electrotechnical Commission (IEC) on all matters of electrotechnical standardization.

Draft International Standards adopted by the technical committees are circulated to the member bodies for voting. Publication as an International Standard requires approval by at least 75 % of the member bodies casting a vote.

International Standard ISO 7992 was prepared by Technical Committee ISO/TC 102, *Iron ores*, Sub-Committee SC 3, *Physical testing*.

[SIST ISO 7992:1998](#)

Annex A forms an integral part of this International Standard.

<http://www.international-standards.org/sist/1824c570-9580-43c6-9a73-f602eb929bb/sist-iso-7992-1998>

© ISO 1992

All rights reserved. No part of this publication may be reproduced or utilized in any form or by any means, electronic or mechanical, including photocopying and microfilm, without permission in writing from the publisher.

International Organization for Standardization  
Case Postale 56 • CH-1211 Genève 20 • Switzerland

Printed in Switzerland

## Introduction

This International Standard describes a test method for evaluation of the physical stability of iron ores reduced under load and under specific conditions. The specific conditions involved in this test are

isothermal heating for reduction;

a test portion having a specified size and placed in a fixed bed under load;

a reducing gas composed of a carbon monoxide/hydrogen/nitrogen mixture;

measurement of the differential gas pressure across a bed of the test portion and measurement of the change in the height of the bed.

This method gives an indication of the physical stability of blast furnace burden materials under conditions resembling those in the blast furnace.

The results of this test should be considered in conjunction with the results of other tests, particularly those showing the physical behaviour of iron ores during reduction.

**iTeh STANDARD PREVIEW**  
**(standards.iteh.ai)**

This page intentionally left blank  
SIST ISO 7992:1998

<https://standards.iteh.ai/catalog/standards/sist/1824c570-9580-43c6-9a73-ff602eb929bb/sist-iso-7992-1998>

# Iron ores — Determination of reduction properties under load

## 1 Scope

This International Standard specifies a method for testing the physical stability of iron ores by measuring the change in the differential gas pressure across a bed of the test portion and the change in the height of the bed during reduction under load. This International Standard is applicable to sized ores and pellets.

## 2 Normative references

The following standards contain provisions which, through reference in this text, constitute provisions of this International Standard. At the time of publication, the editions indicated were valid. All standards are subject to revision, and parties to agreements based on this International Standard are encouraged to investigate the possibility of applying the most recent editions of the standards indicated below. Members of IEC and ISO maintain registers of currently valid International Standards.

ISO 565:1990, *Test sieves — Metal wire cloth, perforated metal plate and electroformed sheet — Nominal sizes of openings*.

ISO 2597:1985, *Iron ores — Determination of total iron content — Titrimetric methods*.

ISO 3081:1986, *Iron ores — Increment sampling — Manual method*.

ISO 3082:1987, *Iron ores — Increment sampling and sample preparation — Mechanical method*.

ISO 3083:1986, *Iron ores — Preparation of samples — Manual method*.

ISO 9035:1989, *Iron ores — Determination of acid-soluble iron(II) content — Titrimetric method*.

ISO 9507:1990, *Iron ores — Determination of total iron content — Titanium(III) chloride reduction methods*.

ISO 9508:1990, *Iron ores — Determination of total iron content — Silver reduction titrimetric method*.

## 3 Principle

Reduction of a bed of the test portion (test bed) with specified size by a carbon/hydrogen gas mixture at a temperature of 1 050 °C, whilst applying a static load.

Monitoring, at regular intervals, the loss in mass of the test portion, the differential gas pressure across the test bed and the height of the test bed.

Determination of the differential pressure and the change in the height of the test bed at an 80 % degree of reduction.

## 4 Test conditions

The gas volumes and flow rates used in this International Standard are measured at a temperature of 0 °C and at atmospheric pressure (101,325 kPa)<sup>1)</sup>.

### 4.1 Composition of reducing gas

The reducing gas shall consist of

CO : (40 ± 0,5 %) (V/V)  
 H<sub>2</sub> : (2 ± 0,5 %) (V/V)  
 N<sub>2</sub> : (58 ± 0,5 %) (V/V)

### 4.2 Purity of reducing gas

Impurities in the reducing gas shall not exceed

O<sub>2</sub> : 0,1 % (V/V)  
 H<sub>2</sub>O : 0,2 % (V/V)  
 CO<sub>2</sub> : 0,2 % (V/V)

1) 1 mm Hg = 0,133 3 kPa; 1 atm = 0,101 325 MPa.

## ISO 7992:1992(E)

**4.3 Flow rate of reducing gas**

The flow rate of the reducing gas shall be maintained at  $83 \text{ l/min} \pm 1 \text{ l/min}$  during the test.

**4.4 Temperature of the reduction test**

The temperature of the bed during the reduction test shall be maintained at a temperature of  $1\ 050 \text{ }^\circ\text{C} \pm 10 \text{ }^\circ\text{C}$ . The reducing gas shall be pre-heated before entering the reduction tube.

**4.5 Loading of the test portion**

During the entire test period, the test portion shall be under a constant load of 50 kPa measured at the surface of the bed.

**5 Apparatus**

Figure 1 shows a schematic example of the test apparatus which shall consist of the following.

**5.1 gas supply system**, capable of supplying the gases and regulating gas flow rates.

**5.2 Reduction tube**, resistant to deformation, made of non-scaling heat resistant metal capable of withstanding a temperature of  $1\ 050 \text{ }^\circ\text{C}$ . The inside diameter of the reduction tube shall be  $125 \text{ mm} \pm 1 \text{ mm}$ .

A removable perforated plate is mounted in the reduction tube to form a bed by supporting the test portion. The plate shall be 10 mm thick; the holes in the plate shall be 3 mm to 4 mm in diameter and shall be separated from each other by 3 mm to 5 mm. The removable plate is placed on a fixed perforated support.

Figure 2 shows an example of the reduction tube, including details of the perforated plate. Figure 3 shows the principle of oxygen flushing of a thermocouple to avoid mismeasurements due to carbon deposition.

**5.3 Furnace**, having a heating capacity which is sufficient to maintain the entire test portion and gas entering the bed at  $1\ 050 \text{ }^\circ\text{C} \pm 10 \text{ }^\circ\text{C}$ .

**5.4 Weighing device**, capable of weighing the load to a sensitivity of 1 g. The weighing device shall be checked for accuracy and sensitivity at regular intervals.

**5.5 Loading device**, capable of applying a total static load of  $50 \text{ kPa} \pm 2 \text{ kPa}$  on a bed of the test portion. The load shall be transferred by means of a rigid perforated footplate (diameter

$120 \text{ mm} \pm 1 \text{ mm}$ ), so as to distribute it evenly onto the surface of the top layer of porcelain pellets placed on the bed. It shall be connected, outside the reduction tube, to a device which will permit measurement of its descending movement during the entire reduction test.

NOTE 1 The actual load may be measured by the application of a load cell placed between the pressure cylinder and the loading ram or by other appropriate methods. The weight of the loading ram is included as part of the total load applied.

**5.6 Device for measuring a differential gas pressure**, capable of a resolution of 0,01 kPa.

**5.7 Height measuring device**, capable of a resolution of 0,1 mm.

**5.8 Test sieves**, having square mesh apertures of the following nominal sizes and conforming to standard specifications for test sieves: 16,0 mm, 12,5 mm and 10,0 mm. (See ISO 565.)

**6 Preparation of test sample****6.1 General**

The test sample shall be prepared, according to the principles described in ISO 3083, from the sample for physical testing which has been taken in accordance with ISO 3081 or ISO 3082. The test sample shall be oven-dried at  $105 \text{ }^\circ\text{C} \pm 5 \text{ }^\circ\text{C}$  for at least 2 h and cooled to room temperature before testing.

**6.2 Sample for reduction test under load**

A quantity of test sample sufficient to provide at least four 1 200 g test portions shall be prepared as follows.

## a) Pellets

The test sample having a particle size between 10,0 mm and 12,5 mm shall be obtained by sieving and, after sieving, only pellets taken at random from this sample shall be used for the test.

## b) Sized ores

The test sample having a particle size between 10,0 mm and 12,5 mm shall be prepared as follows. Sieve the sample on a 12,5 mm sieve and carefully crush the + 12,5 mm material until all of the material passes the 16,0 mm sieve. Combine all fractions and remove by sieving the + 12,5 mm and the - 10,0 mm material from the sample.

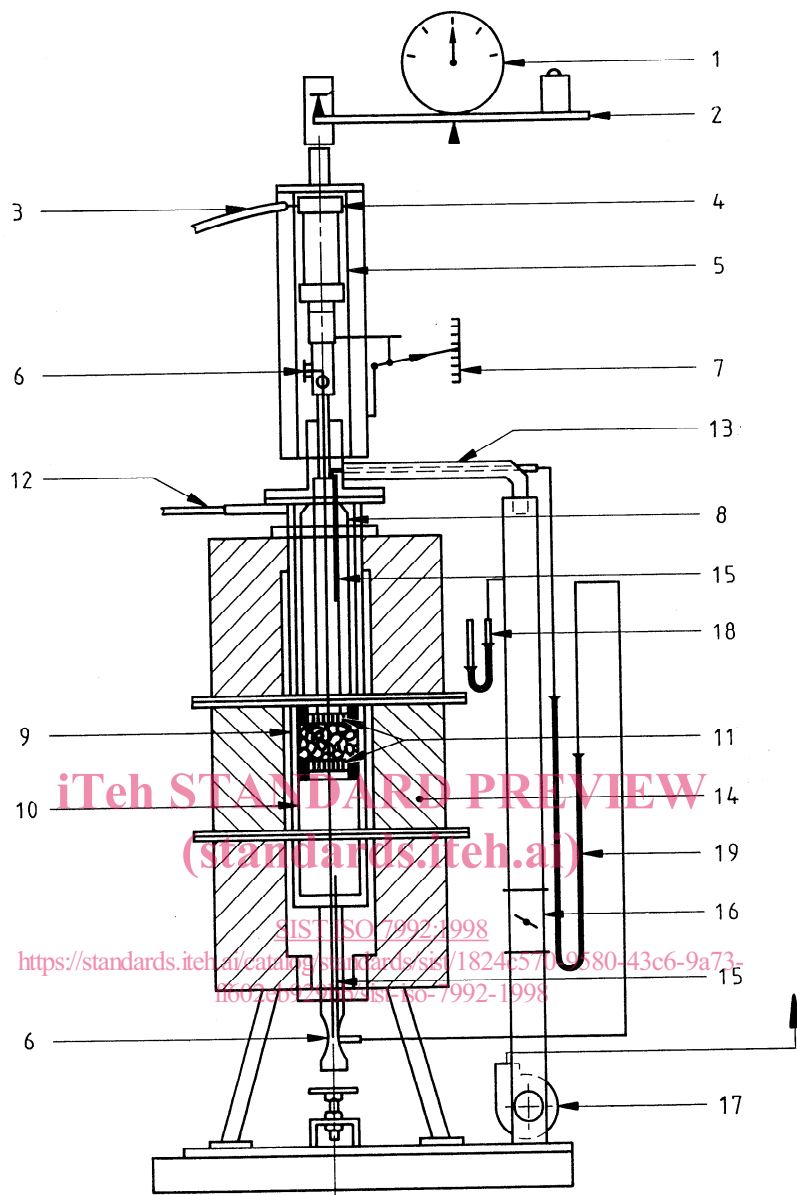

**Key****Gas supply system (5.1)**

- 12 Reducing gas inlet
- 13 Reducing gas outlet

**Reduction tube (5.2)**

- 9 Outer reduction tube
- 10 Inner reduction tube
- 11 Upper and lower perforated plates comprising the test portion
- 6 Thermocouple exit (top/bottom)

**Furnace (5.3)**

- 14 Main furnace body

**Weighing device (5.4)**

- 1 Scale
- 2 Balance

**Loading device (5.5)**

- 3 Compressed air inlet
- 4 Pressure cylinder
- 5 Frame for pressure cylinder
- 8 Loading ram

**Differential gas pressure measuring device (5.6)**

- 15 Differential gas pressure upper and lower probes
- 19 Differential gas pressure manometer

**Height measuring device (5.7)**

- 7 Linear scale

**Waste gas**

- 16 Throttle valve
- 17 Waste gas fan
- 18 Suction gauge

**Figure 1 — Example of apparatus for determining reduction properties under load**