International Standard



8007

INTERNATIONAL ORGANIZATION FOR STANDARDIZATION • МЕЖДУНАРОДНАЯ ОРГАНИЗАЦИЯ ПО СТАНДАРТИЗАЦИИ • ORGANISATION INTERNATIONALE DE NORMALISATION

Carbonaceous materials used in the production of aluminium — Sampling from cathodic blocks and prebaked anodes — General

Produits carbonés utilisés pour la production de l'aluminium — Échantillonnage de blocs cathodiques et d'anodes précuites — Généralités

iteh STANDARD PREVIEW

First edition — 1985-11-01

(standards.iteh.ai)

[ISO 8007:1985](#)

<https://standards.iteh.ai/catalog/standards/sist/5a8334be-fba8-4eb0-ba04-0aa0254cde8c/iso-8007-1985>

UDC 665.777 : 669.713 : 620.11

Ref. No. ISO 8007-1985 (E)

Descriptors: industrial products, carbon, electrodes, cathodes, anodes, sampling, aluminium, production.

Foreword

ISO (the International Organization for Standardization) is a worldwide federation of national standards bodies (ISO member bodies). The work of preparing International Standards is normally carried out through ISO technical committees. Each member body interested in a subject for which a technical committee has been established has the right to be represented on that committee. International organizations, governmental and non-governmental, in liaison with ISO, also take part in the work.

Draft International Standards adopted by the technical committees are circulated to the member bodies for approval before their acceptance as International Standards by the ISO Council. They are approved in accordance with ISO procedures requiring at least 75 % approval by the member bodies voting.

International Standard ISO 8007 was prepared by Technical Committee ISO/TC 47, *Chemistry*.

Users should note that all International Standards undergo revision from time to time and that any reference made herein to any other International Standard implies its latest edition, unless otherwise stated.

Carbonaceous materials used in the production of aluminium — Sampling from cathodic blocks and prebaked anodes — General

1 Scope and field of application

This International Standard gives instructions for taking test samples from cathodic blocks and prebaked anodes the quality of which is defined in a contract specification.

The object of this International Standard is to indicate the positions for taking test samples from cathodic blocks or prebaked anodes. It does not describe the operations of sampling from a large consignment or from a lot.

The "overall" dimensions of the sample shall enable a cut to be made having the dimensions required for the test, with a tolerance of $\pm 0,1$ mm. Furthermore, the dimensions of the sample shall also allow for the provision of parallel sides.

The cross-section of the test sample may be square or circular.

The length of the test sample shall be at least 1,5 times the diameter of the core or of the diagonal of the square.

2 References

ISO 3165, *Sampling of chemical products for industrial use — Safety in sampling*.

ISO 6206, *Chemical products for industrial use — Sampling — Vocabulary*.

3 Definitions

For the purpose of this International Standard, the definitions given in ISO 6206 apply.

4 Apparatus

Use cutting edges coated preferably with diamond or other extremely hard material.

5 Dimensions of test sample

The dimensions of the samples shall be chosen according to the tests to be carried out on the product to be analysed. Reference should therefore be made to the International Standards relating to the test to be carried out.

The minimum dimension should be 3 or 4 times the maximum particle size of the dry aggregate.

6 Procedure

<https://standards.iteh.ai/catalog/standards/sist/5a8334be-fba8-4eb0-ba04-0aa0254cde8c/iso-8007-1985>

Take the samples by core drilling or by sawing using the apparatus indicated in clause 4.

Figure 1 (cathodic blocks) and figure 2 (prebaked anodes) give, in principle, the location and the direction of sampling in the blocks.

NOTE — The application of the sampling procedure shall not cause, so far as is possible, contamination, weakening or destruction of the block.

7 Sampling report

The sampling report shall contain the following information:

- identification of the sample (cathodic block or prebaked anode);
- reference to the present International Standard and to the International Standard specifying the test to be carried out;
- procedure used for sampling (core drilling or sawing);
- dimensions of the test sample;
- any unusual features noted during the sampling;
- any operations not included in this International Standard or in the International Standards to which reference is made or regarded as optional.

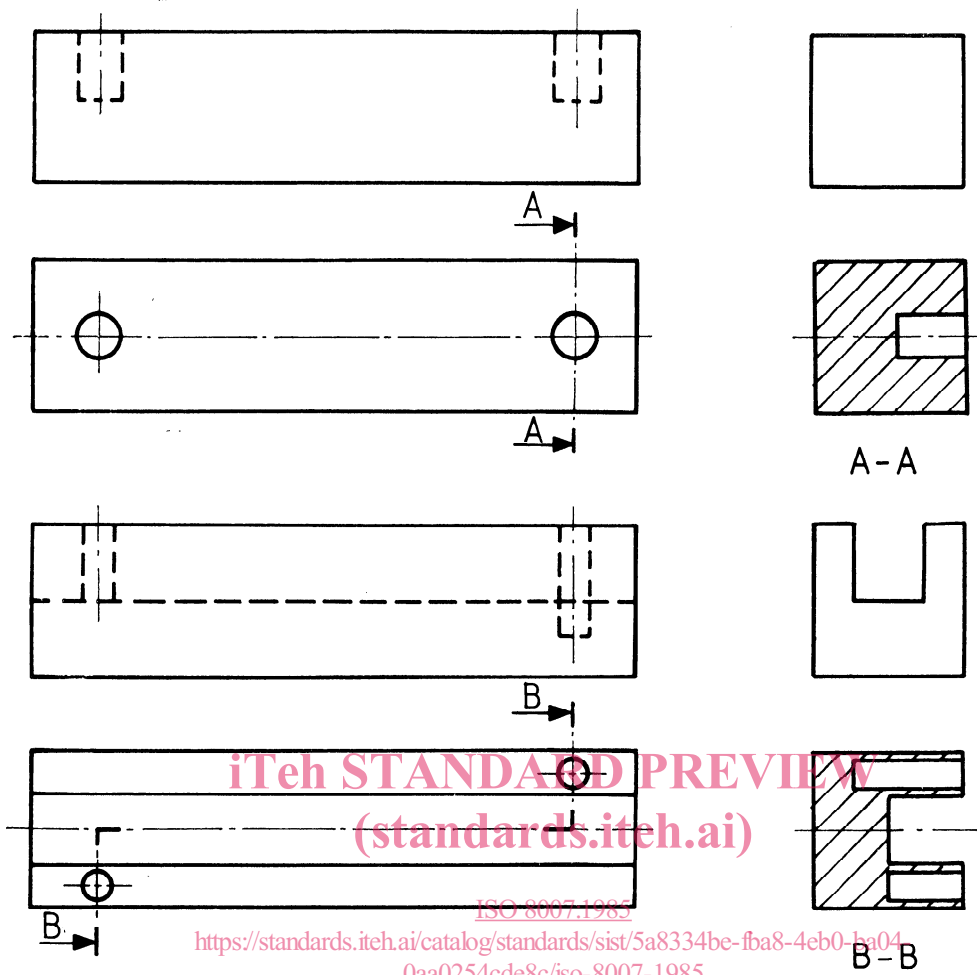

Figure 1 — Cathodic blocks

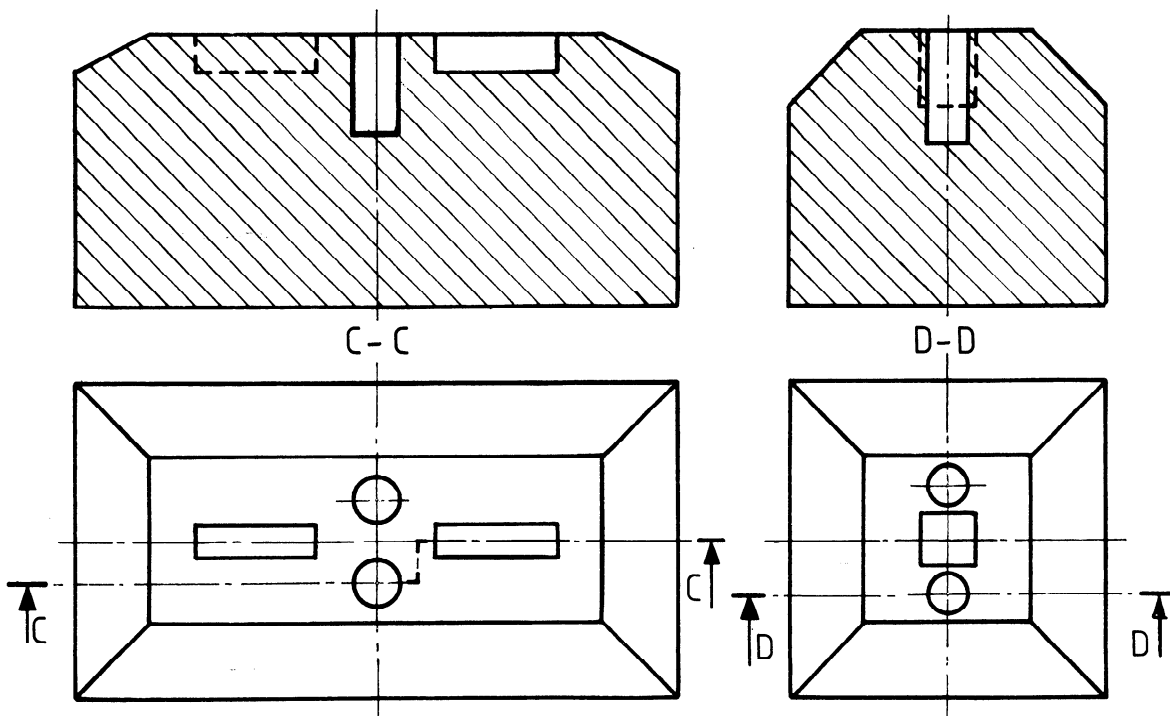

Figure 2 — Prebaked anodes