

INTERNATIONAL STANDARD

ISO
8031

First edition
1987-12-15



INTERNATIONAL ORGANIZATION FOR STANDARDIZATION
ORGANISATION INTERNATIONALE DE NORMALISATION
МЕЖДУНАРОДНАЯ ОРГАНИЗАЦИЯ ПО СТАНДАРТИЗАЦИИ

Rubber and plastics hoses and hose assemblies — Determination of electrical resistance

Tuyaux et flexibles en caoutchouc et en plastique — Détermination de la résistance électrique

iTeh STANDARD PREVIEW

(standards.iteh.ai)

ISO 8031:1987

<https://standards.iteh.ai/catalog/standards/sist/52ab8e3a-9235-48f9-be1b-95f4fed9c660/iso-8031-1987>

Reference number
ISO 8031 : 1987 (E)

Foreword

ISO (the International Organization for Standardization) is a worldwide federation of national standards bodies (ISO member bodies). The work of preparing International Standards is normally carried out through ISO technical committees. Each member body interested in a subject for which a technical committee has been established has the right to be represented on that committee. International organizations, governmental and non-governmental, in liaison with ISO, also take part in the work.

Draft International Standards adopted by the technical committees are circulated to the member bodies for approval before their acceptance as International Standards by the ISO Council. They are approved in accordance with ISO procedures requiring at least 75 % approval by the member bodies voting.

International Standard ISO 8031 was prepared by Technical Committee ISO/TC 45, *Rubber and rubber products*.

Users should note that all International Standards undergo revision from time to time and that any reference made herein to any other International Standard implies its latest edition, unless otherwise stated.

<https://standards.iteh.ai/catalog/standards/sist/52ab8e3a-9235-48f9-be1b-95f4fed9c660/iso-8031-1987>

ITeH STANDARD PREVIEW
(standards.iteh.ai)

Rubber and plastics hoses and hose assemblies — Determination of electrical resistance

1 Scope and field of application

This International Standard specifies methods for electrical tests on rubber and plastics hoses and hose assemblies to determine the resistance of conductive, antistatic and non-conductive hoses, the electrical continuity between fittings, and the electrical discontinuity.

2 References

ISO 291, *Plastics — Standard atmospheres for conditioning and testing.*

ISO 471, *Rubber — Standard temperatures, humidities and times for the conditioning and testing of test pieces.*

ISO 2878, *Rubber, vulcanized — Antistatic and conductive products — Determination of electrical resistance.*

3 Measurement of resistance of conductive, antistatic and non-conductive hoses

Rubber hoses may have a conducting lining only or a conducting cover only, or may be manufactured from conducting rubber compounds throughout. A method of test is specified for each of the three possible types of construction.

3.1 Apparatus

The following apparatus is required and shall be basically as described in ISO 2878.

3.1.1 Testing instruments

3.1.1.1 To determine the resistance of conductive, antistatic and non-conductive hose, the test shall be made preferably with an instrument specifically designed for measuring insulation resistance, having a nominal open circuit voltage of 500 V d.c., or with any other instrument known to give comparable results. The instrument shall be sufficiently accurate to determine the resistance within $\pm 10\%$. During the test, not more than 3 W shall be dissipated in the specimen to prevent

erroneous results due to effects of temperature. The power dissipated shall be determined by the square of the open-circuit voltage divided by the measured resistance.

The resistance values obtained will vary with the applied voltage, and errors may occur when low test voltages are involved. In case of dispute, the voltage applied to the test piece shall be not less than 40 V, except where this conflicts with the requirement not to dissipate more than 3 W in the test piece.

3.1.1.2 For tests requiring measurement of electrical continuity between end fittings or through continuous internal or external bonded wires, the instrument used shall be an ohmmeter sufficiently accurate to determine the resistance within $\pm 10\%$.

3.1.2 Electrodes and contacts

Electrodes shall be formed on the surface as bands 25^{+2}_0 mm wide around the circumference by means of a conductive silver lacquer, colloidal graphite or a conductive liquid.

When a conductive liquid is used, the electrode contact area shall be completely wetted and shall remain so until the end of the test. The conductive liquid shall consist of

- anhydrous polyethylene glycol of relative molecular mass 600: 800 parts by mass;
- water: 200 parts by mass;
- wetting agent: 1 part by mass;
- potassium chloride: 10 parts by mass.

When a conductive silver lacquer or colloidal graphite is used, the surface resistance between any two points on a sample of the dried film shall not exceed 100 Ω .

Clean metal contacts shall be applied to the electrodes so that the contact area is approximately the same size as, but no greater than, the electrodes, except where otherwise stated.

In the case of hoses of less than 50 mm bore, it is difficult to apply the conducting liquid accurately to the hose bore, and it

is preferable to use a brass plug of external diameter equal to the hose internal diameter, coated with conducting liquid, and then pushed 25 mm into the hose.

3.2 Preparation and cleaning for test

The surfaces of the hose or test piece shall be clean. If necessary, they may be cleaned by rubbing with fuller's earth (magnesium aluminium silicate) and water, washing with distilled water and allowing to dry. Do not use organic materials which attack or swell the rubber, and do not buff or abrade the test surfaces.

The surface of the hose shall not be deformed either during the application of the contacts or during test. When using test pieces, the supports shall be outside the test length. When using a long length of hose, the hose shall be uncoiled and laid straight on polyethylene or other insulating material. Care shall be taken to ensure that the hose is insulated from any leakage path along the length of hose.

3.3 Conditioning

The articles shall be conditioned for at least 16 h under one of the following standard conditions in accordance with ISO 291 or ISO 471:

23 ± 2 °C and 50 ± 5 % relative humidity

or

27 ± 2 °C and 65 ± 5 % relative humidity.

However, where very long lengths of hoses are being tested, it is permissible, by agreement between supplier and customer, to use the conditions prevailing in the factory, warehouse or laboratory, provided that the relative humidity is not greater than 70 %.

3.4 Procedure for hoses with conducting lining

(on full hose length)

Apply the electrodes as specified in 3.1.2 on the inside surface at each end of the hose. The edge of the electrode band shall be coincident with the end of the hose. When using a conducting liquid, care shall be taken to avoid creating a leakage path between the lining and the reinforcement or cover of the hose.

Apply the metal contacts to the electrodes.

Apply the test voltage and measure the resistance 5 ± 1 s after the application of that voltage.

3.5 Procedure for hoses with conducting cover

3.5.1 Method 1 (on full hose length)

Apply the electrodes as specified in 3.1.2 on the outside surface at each end of the hose.

Apply the metal contacts.

Apply the test voltage and measure the resistance 5 ± 1 s after the application of that voltage.

3.5.2 Method 2 (on test pieces)

3.5.2.1 Test pieces

Prepare the test pieces by cutting five lengths of hose approximately 300 mm long from samples taken at random from a production run. Condition the test pieces in accordance with 3.3.

Position the electrodes as specified in 3.1.2 symmetrically along the test piece so that the distance between their nearest edges is 100 ± 1 mm. (See the figure.)

Ensure that contact is maintained with the electrodes around the circumference and that the contact pieces are sufficiently long for the two free ends to be held securely by a tensioning clip (see the figure) such that the fit of the electrodes is as tight as possible, consistent with the means employed.

3.5.2.2 Test procedure

Place the test piece on blocks of polyethylene, or other insulating material, to provide a resistance of greater than 10¹¹ Ω between the test piece and the surface on which the blocks are supported. Ensure that the leads from the instrument do not touch each other, the hose, or any part except the terminal to which each is connected. Connect the leads from the testing instrument to the appropriate contact piece.

Apply the test voltage and measure the resistance 5 ± 1 s after the application of that voltage.

NOTE — Care should be taken to avoid breathing on the test surfaces and thus creating condensation that may lead to inaccuracies.

3.6 Procedure for hoses with conducting compounds throughout

3.6.1 Method 1 (hoses up to 6 m in length)

3.6.1.1 Apply the electrodes as specified in 3.1.2 on the inside surface at one end of the hose (end A) and on the outside surface at the other end (end B).

Apply the metal contacts to the electrodes.

Apply the test voltage and measure the resistance 5 ± 1 s after the application of that voltage.

3.6.1.2 Repeat the test, applying the electrodes to the outside surface at end A and to the inside surface at end B.

3.6.2 Method 2 (hoses over 6 m in length)

3.6.2.1 Apply the electrodes as specified in 3.1.2 on the inside surface at one end of the hose and on the outside surface at distances of 3 m and 6 m from the same end.

Apply the metal contacts to the inside electrode and to the outside electrode at 3 m from the inside electrode.

Apply the test voltage and measure the resistance 5 ± 1 s after the application of that voltage.

3.6.2.2 Repeat the test between the inside electrode and the outside electrode at 6 m from the inside electrode. The difference between these resistance values shall be regarded as the resistance for 3 m of the hose.

3.6.2.3 Repeat the tests at the other end of the hose length.

NOTE — The purpose of this test is not only to measure and compare the resistance of the end 3 m of hose but to ensure that the homogeneity of the hose construction is maintained throughout during manufacture.

3.7 Hose assemblies fitted with metal end couplings

3.7.1 When it is required that the resistance of a hose assembly be measured, the leads of the test instrument shall be attached directly to the metal end couplings.

3.7.2 Some hoses, especially thermoplastics hoses, have conductive layers within the hose construction. These hoses shall be tested as assemblies made with fittings and assembly techniques called for by the hose and fitting manufacturer.

4 Measurement of electrical continuity

In certain types of hose construction, electrical continuity is provided between the end fittings by means of a continuous wire or wires bonded to each coupling. When the construction is such that there are internal and external wires, the electrical continuity of both wires shall be established using a suitable ohmmeter as described in 3.1.1.2.

It is essential that contact resistance between the end fittings and the meter is minimized.

5 Measurement of electrical discontinuity

In certain types of hose containing wire in the construction, it is required that such wire be insulated from the end fittings. In these cases, condition the hose in accordance with 3.3 and measure the resistance between the fittings as described in 3.7.

It is essential that contact resistance between the end fittings and the meter is minimized.

6 Test report

The test report shall include items a) to d) and, as appropriate, e) to k):

- a) the hose type and nominal bore;
- b) a reference to this International Standard;
- c) the conditioning and test atmosphere, i.e. the temperature and relative humidity;
- d) the distance between the electrodes;
- e) the electrode material used;
- f) the resistance, in ohms per metre, of the hose lining, and the test method used;
- g) the resistance, in ohms per metre, of the hose cover, and the test method used, detailing the individual readings;
- h) the resistance, in ohms per metre, of the hose from lining to cover, and the test method used, detailing the individual readings;
- i) the resistance, in ohms per metre, of the hose assembly between couplings, and the test method used;
- j) whether electrical continuity has been established;
- k) the insulation resistance, in ohms, obtained when establishing electrical discontinuity.

Dimensions in millimetres

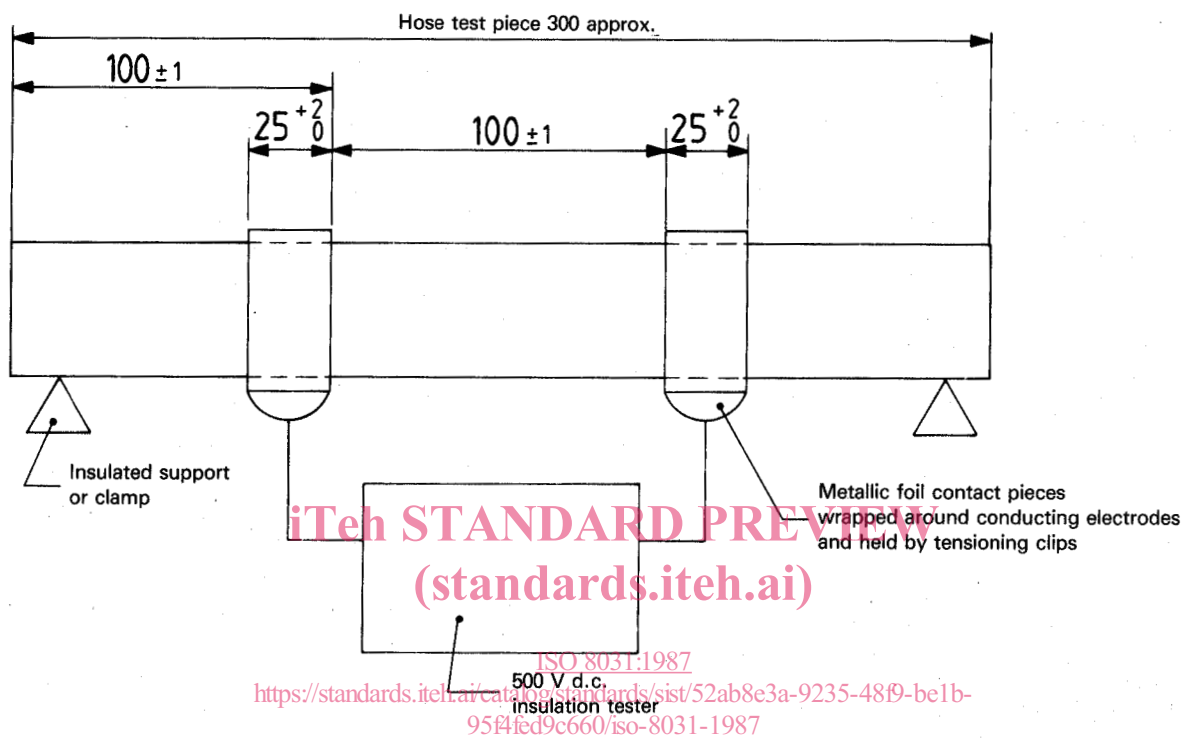

Figure — Electrodes and contacts for testing as described in 3.5.2.1

iTeh STANDARD PREVIEW
(standards.iteh.ai)

ISO 8031:1987

<https://standards.iteh.ai/catalog/standards/sist/52ab8e3a-9235-48f9-be1b-95f4fed9c660/iso-8031-1987>

iTeh STANDARD PREVIEW
(standards.iteh.ai)

ISO 8031:1987

<https://standards.iteh.ai/catalog/standards/sist/52ab8e3a-9235-48f9-be1b-95f4fed9c660/iso-8031-1987>

UDC 621.643.33 : 621.317.33

Descriptors : rubber products, plastics products, hoses, tests, electrical tests, determination, electrical resistance.

Price based on 4 pages
