



SLOVENSKI STANDARD
SIST EN 12958:2002

01-januar-2002

Footwear - Test methods for shanks - Fatigue resistance

Footwear - Test methods for shanks - Fatigue resistance

Schuhe - Prüfverfahren für Gelenke - Ermüdungswiderstand

Chaussures - Méthodes d'essai pour cambrions - Résistance à la fatigue

Ta slovenski standard je istoveten z: EN 12958:2000

[SIST EN 12958:2002](https://standards.iteh.ai/catalog/standards/sist/5598ce47-ac2b-4a1a-b12c-8e6e9c1e0f50/sist-en-12958-2002)

<https://standards.iteh.ai/catalog/standards/sist/5598ce47-ac2b-4a1a-b12c-8e6e9c1e0f50/sist-en-12958-2002>

ICS:

61.060

Obuvala

Footwear

SIST EN 12958:2002

en

iTeh STANDARD PREVIEW
(standards.iteh.ai)

SIST EN 12958:2002

<https://standards.iteh.ai/catalog/standards/sist/5598ce47-ac2b-4a1a-b12c-8e6e9c1e0f50/sist-en-12958-2002>

EUROPEAN STANDARD
NORME EUROPÉENNE
EUROPÄISCHE NORM

EN 12958

February 2000

ICS 61.060

English version

Footwear — Test methods for shanks — Fatigue resistance

Chaussures — Méthodes d'essai pour cambrions — Schuhe — Prüfverfahren für Gelenke —
Résistance à la fatigue Ermüdungswiderstand

This European Standard was approved by CEN on 1 January 2000.

CEN members are bound to comply with the CEN/CENELEC Internal Regulations which stipulate the conditions for giving this European Standard the status of a national standard without any alteration. Up-to-date lists and bibliographical references concerning such national standards may be obtained on application to the Central Secretariat or to any CEN member.

This European Standard exists in three official versions (English, French, German). A version in any other language made by translation under the responsibility of a CEN member into its own language and notified to the Central Secretariat has the same status as the official versions.

CEN members are the national standards bodies of Austria, Belgium, Czech Republic, Denmark, Finland, France, Germany, Greece, Iceland, Ireland, Italy, Luxembourg, Netherlands, Norway, Portugal, Spain, Sweden, Switzerland and United Kingdom.

CEN

European Committee for Standardization
Comité Européen de Normalisation
Europäisches Komitee für Normung

Central Secretariat: rue de Stassart 36, B-1050 Brussels

Foreword

This European Standard has been prepared by Technical Committee CEN/TC 309, Footwear, the Secretariat of which is held by AENOR.

This European Standard shall be given the status of a national standard, either by publication of an identical text or by endorsement, at the latest by August 2000, and conflicting national standards shall be withdrawn at the latest by August 2000.

According to the CEN/CENELEC Internal Regulations, the national standards organizations of the following countries are bound to implement this European Standard: Austria, Belgium, Czech Republic, Denmark, Finland, France, Germany, Greece, Iceland, Ireland, Italy, Luxembourg, Netherlands, Norway, Portugal, Spain, Sweden, Switzerland and the United Kingdom.

Contents

| | Page |
|-----------------------------|------|
| Foreword | 2 |
| 1 Scope | 3 |
| 2 Normative references | 3 |
| 3 Definitions | 3 |
| 4 Apparatus and materials | 3 |
| 5 Sampling and conditioning | 3 |
| 6 Test method | 3 |
| 7 Expression of results | 3 |
| 8 Test report | 3 |

iTeh STANDARD PREVIEW
(standards.iteh.ai)

[SIST EN 12958:2002](https://standards.iteh.ai/catalog/standards/sist/5598ce47-ac2b-4a1a-b12c-8e6e9c1e0f50/sist-en-12958-2002)

<https://standards.iteh.ai/catalog/standards/sist/5598ce47-ac2b-4a1a-b12c-8e6e9c1e0f50/sist-en-12958-2002>

1 Scope

This European Standard specifies a method for assessing the fatigue resistance of steel shanks used for the reinforcement of the waist region of women's shoes and of some men's and children's shoes.

2 Normative references

This European Standard incorporates by dated or undated reference, provisions from other publications. These normative references are cited at the appropriate places in the text and the publications are listed hereafter. For dated references, subsequent amendments to or revisions of any of these publications apply to this European Standard only when incorporated in it by amendment or revision. For undated references the latest edition of the publication referred to applies.

EN 12222, *Footwear — Standard atmospheres for conditioning and testing of footwear and components for footwear.*

3 Definitions

For the purposes of this standard the following definition applies.

3.1

fatigue resistance

the resistance of a shank, under specified conditions, to repeated loading cycles

4 Apparatus and materials

A test machine shall be used to measure the fatigue resistance of steel shanks. For multi station machines each station shall include the items described in a) to d).

- A fixed lower jaw with flat hardened steel face plates of height $32 \text{ mm} \pm 2 \text{ mm}$ and of width suitable to securely clamp the shank.
- An adjustable upper jaw with flat hardened steel face plates with a means of exerting a force of $49 \text{ N} \pm 2 \text{ N}$ on the shank perpendicular to the plane of the lower clamp faces at a rate of four cycles per second. One complete cycle being the application of the load in a forward and reverse direction as in a simple harmonic motion.

An illustration of suitable upper and lower jaw configuration is given in Figure 1.

- A method of counting the number of complete cycles up to break of the specimen.
- A method of controlling the clamping force of the jaws see items a) and b), to $4\,900 \text{ N}\cdot\text{mm} \pm 50 \text{ N}\cdot\text{mm}$.

NOTE A torque wrench is suitable.

5 Sampling and conditioning

The test specimen shall be a complete shank.

At least four samples of each type of shank shall be tested.

Condition samples for 48 h prior to testing in a controlled atmosphere in accordance with EN 12222.

Tests shall be carried out in a suitable conditioned atmosphere in accordance with EN 12222, or, where this is not possible tests shall be carried out within 15 minutes of removing the test specimen from the conditioned atmosphere.

6 Test method

The shank is clamped at its rear end as it would be in a shoe and bent as a cantilever beam by an alternating force applied to the shank. The number of loading cycles required to break the shank is termed the fatigue life.

Insert the heel end of the shank centrally in the lower jaw [see 4a)] so that 32 mm of shank are clamped with the end of the shank level with the bottom edge of the jaw and the specimen is perpendicular to the clamping forces of the lower jaw.

Close and tighten the lower jaw [see 4a)] ensuring that the torque exerted at the upper edge of the jaw is $4\,900 \text{ N}\cdot\text{mm}$ by using a device according to 4d). Such a high torque does not need to be applied to the lower edge of the clamp, but apply sufficient to ensure that the lower edge is secure and that the faces of the jaws remain parallel.

Place the upper jaw [see 4b)] on the specimen so that the distance between the top edge of the lower clamp [see 4a)] and the center of the upper jaw [see 4b)] is $70 \text{ mm} \pm 2 \text{ mm}$. Uniformly close and tighten the upper jaw [see 4b)] ensuring that the total torque exerted is $4\,900 \text{ N}\cdot\text{mm}$ see 4d).

7 Expression of results

Operate the testing machine and record the total number of load cycles as each specimen breaks.

For each specimen report the total number of load cycles to break and calculate the arithmetic mean of the four results.

8 Test report

The test report shall include the following information:

- results, expressed in accordance with clause 7;
- reference to this test method;
- full description of the samples tested including commercial styles codes, colours, nature, etc.;
- the number of test specimens if other than four;
- any deviations from this standard method;
- date of testing.

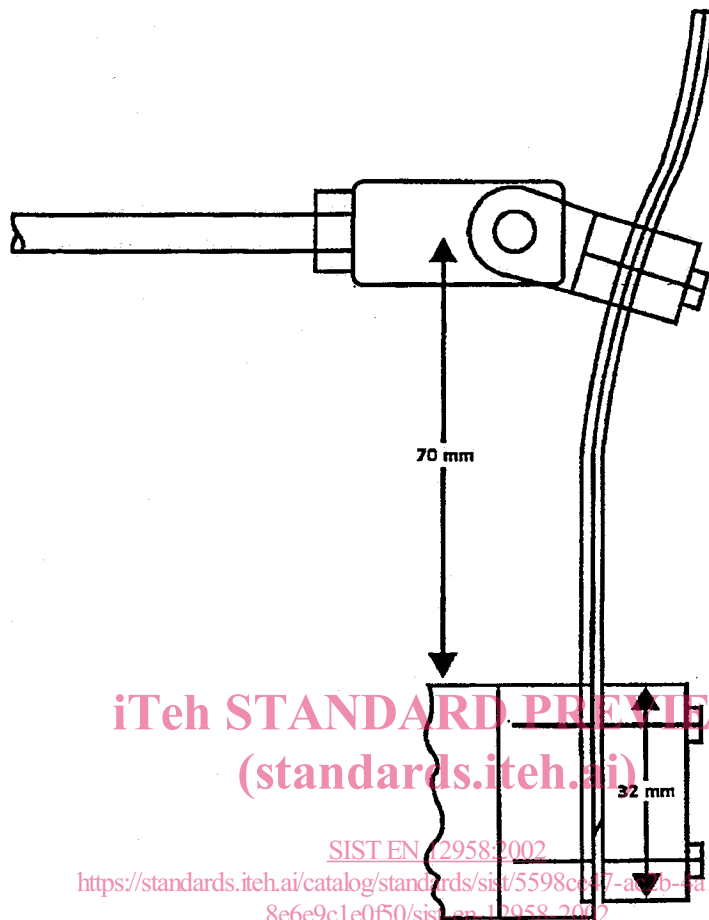

Figure 1