



SLOVENSKI STANDARD

SIST ISO 8082:1995

01-november-1995

Gozdarski stroji z lastnim pogonom - Zaščitne strukture proti prevrnitvi - Laboratorijski preskusi in zahtevane lastnosti

Self-propelled machinery for forestry -- Roll-over protective structures -- Laboratory tests and performance requirements

iTeh STANDARD PREVIEW

Machines forestières automotrices -- Structures de protection au retournement -- Essais de laboratoire et critères de performance

[SIST ISO 8082:1995](https://standards.iteh.ai/catalog/standards/sist/df71ca21-3c2d-4173-883a-5481379988b4/sist-iso-8082-1995)

Ta slovenski standard je istoveten z: **ISO 8082:1994**

ICS:

65.060.80 Gozdarska oprema Forestry equipment

SIST ISO 8082:1995

en

iTeh STANDARD PREVIEW
(standards.iteh.ai)

[SIST ISO 8082:1995](#)

<https://standards.iteh.ai/catalog/standards/sist/df71ca21-3c2d-4173-883a-5481379988b4/sist-iso-8082-1995>

INTERNATIONAL
STANDARD

ISO
8082

First edition
1994-02-15

**Self-propelled machinery for forestry —
Roll-over protective structures —
Laboratory tests and performance
requirements**
(standards.iteh.ai)

*Machines forestières automotrices — Structures de protection au
retournement — Essais de laboratoire et critères de performance*
<https://standards.iteh.ai/catalog/standards/sist/df71ca21-3c2d-4173-883a-5481379988b4/sist-iso-8082-1995>



Reference number
ISO 8082:1994(E)

ISO 8082:1994(E)**Foreword**

ISO (the International Organization for Standardization) is a worldwide federation of national standards bodies (ISO member bodies). The work of preparing International Standards is normally carried out through ISO technical committees. Each member body interested in a subject for which a technical committee has been established has the right to be represented on that committee. International organizations, governmental and non-governmental, in liaison with ISO, also take part in the work. ISO collaborates closely with the International Electrotechnical Commission (IEC) on all matters of electrotechnical standardization.

Draft International Standards adopted by the technical committees are circulated to the member bodies for voting. Publication as an International Standard requires approval by at least 75 % of the member bodies casting a vote.

International Standard ISO 8082 was prepared by Technical Committee ISO/TC 23, *Tractors and machinery for agriculture and forestry*, Subcommittee SC 15, *Machinery for forestry*.

Annex A forms an integral part of this International Standard.

© ISO 1994

All rights reserved. Unless otherwise specified, no part of this publication may be reproduced or utilized in any form or by any means, electronic or mechanical, including photocopying and microfilm, without permission in writing from the publisher.

International Organization for Standardization
Case Postale 56 • CH-1211 Genève 20 • Switzerland

Printed in Switzerland

Self-propelled machinery for forestry — Roll-over protective structures — Laboratory tests and performance requirements

1 Scope

This International Standard establishes a consistent, reproducible means of evaluating force-deflection characteristics of Roll-Over Protective Structures (ROPS) under static loading, and prescribes performance requirements for a representative specimen under such loading.

It applies to mobile and self-propelled specially designed machinery for forestry such as forwarders, skidders, processors, harvesters and loaders as defined in ISO 6814.

2 Normative references

The following standards contain provisions which, through reference in this text, constitute provisions of this International Standard. At the time of publication, the editions indicated were valid. All standards are subject to revision, and parties to agreements based on this International Standard are encouraged to investigate the possibility of applying the most recent editions of the standards indicated below. Members of IEC and ISO maintain registers of currently valid International Standards.

ISO 148:1983, *Steel — Charpy impact test (V-notch)*.

ISO 898-1:1988, *Mechanical properties of fasteners — Part 1: Bolts, screws and studs*.

ISO 898-2:1992, *Mechanical properties of fasteners — Part 2: Nuts with specified proof load values — Coarse thread*.

ISO 3164:1992, *Earth-moving machinery — Laboratory evaluations of roll-over and falling-object protective structures — Specifications for deflection-limiting volume*.

ISO 6814:1983, *Machinery for forestry — Mobile and self-propelled machinery — Identification vocabulary*.

ISO 8083:1989, *Machinery for forestry — Falling-object protective structures — Laboratory tests and performance requirements*.

ISO 8084:1993, *Machinery for forestry — Operator protective structures — Laboratory tests and performance requirements*.

3 Definitions

For the purposes of this International Standard, the following definitions apply.

3.1 roll-over protective structure (ROPS): System of structural members whose primary purpose is to reduce the possibility of a seat-belted operator being crushed should the machine roll over. Structural members include any subframe, bracket, mounting, socket, bolt, pin, suspension or flexible shock absorber used to secure the system to the machine frame, but exclude mounting provisions that are integral with the machine frame.

3.2 deflection-limiting volume (DLV): That volume, related to the operator, which serves to set limits and deflections permissible when performing laboratory evaluations of ROPS, FOPS and OPS. The volume, an approximation, is based on the seated dimensions of the large operator. (See ISO 3164:1992, figure 1.)

3.3 falling-object protective structure (FOPS): System of structural members arranged in such a way as to provide operators with reasonable protection from falling objects (for example, trees, rocks). (See ISO 8083.)

3.4 operator protective structure (OPS): System of structural members arranged in such a way as to provide operators with reasonable protection from penetrating objects. (See ISO 8084.)

3.5 simulated ground plane (SGP): Flat surface on which a forestry machine after rolling over is assumed to come to rest.

3.5.1 lateral simulated ground plane (LSGP): For a machine coming to rest on its side, the plane 15° away from the DLV about the horizontal axis within the plane established in the vertical plane passing through the outermost point. This establishes the

LSGP. The LSGP is established on an unloaded ROPS and moves with the member to which load is applied while maintaining its 15° angle with respect to the vertical.

3.5.2 vertical simulated ground plane (VSGP): For a machine coming to rest in an upside-down position, the plane is defined by the top cross-member of the ROPS and that front (rear) part of the machine likely to come in contact with flat ground at the same time as the ROPS and capable of supporting the upside-down machine. The VSGP moves with the deformed ROPS. (See figure 2.)

NOTE 1 The VSGP applies only to rollbar ROPS.

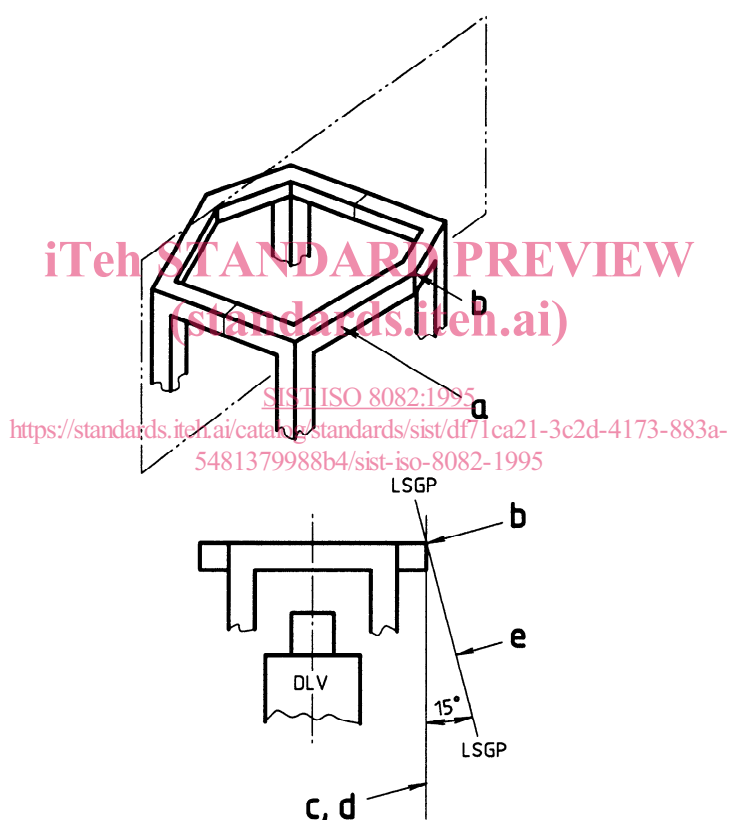

Key

- a Upper ROPS member to which the lateral load is applied
- b Outermost point from the end view of member a
- c Vertical line through point b
- d Vertical plane parallel to the machine longitudinal centreline through line c
- e Lateral simulated ground plane

Figure 1 — Determination of lateral simulated ground plane (LSGP)

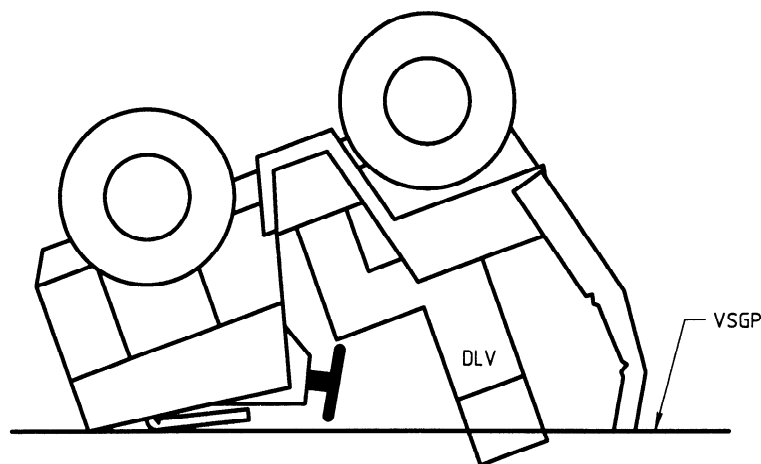

Figure 2 — Intrusion of vertical simulated ground plane (VSGP) into DLV

4 Symbols

The following symbols are used in this International Standard.

4.1 *U*: Energy absorbed by the structure, related to the machine mass, expressed in joules.

4.2 *F*: Force, expressed in newtons.

4.3 *M*: Machine mass, expressed in kilograms, is

- a) the maximum mass declared by the manufacturer, including attachments in the operating condition and with tools, ROPS and all reservoirs filled, but excluding towed equipment such as chippers, planters and discs, and the load carried on the machine;
- b) for articulated machines where, when moving, one member can roll about the longitudinal axis unrestrained by the remaining member of the machine, the mass is the manufacturer's declared mass for the ROPS-bearing member only (normally the prime mover).

Unrestrained is understood to mean unlimited rotation about the longitudinal axis, between the members: if stops or locks are provided which, during driving, limit roll about the longitudinal axis, the whole machine mass is used. (See figure 3.)

4.4 Δ : Deflection of the ROPS, expressed in millimetres.

5 Static laboratory tests

5.1 Facilities

Facilities for securing the ROPS/machine frame assembly to the bedplate, as described below, and for applying the lateral and vertical loads shall be provided.

The DLV and its location shall be in accordance with ISO 3164. The DLV shall be fixed firmly to the same part of the machine to which the operator's seat is normally secured, and shall remain there during the entire formal test period.

5.2 Instruments

The test apparatus shall be equipped with instruments for measuring the force applied to the protective structure and the deflection (deformation) of the structure. The instrument accuracy shall meet the requirements given in table 1.

Table 1 — Instrument accuracy requirements

Measurement	Accuracy ¹⁾
Deflection of ROPS	$\pm 5\%$ of maximum deflection measured
Force applied to ROPS	$\pm 5\%$ of maximum force measured

1) The percentages are nominal ratings of the accuracy of the instrumentation and shall not be taken to indicate that compensating overtest is required.

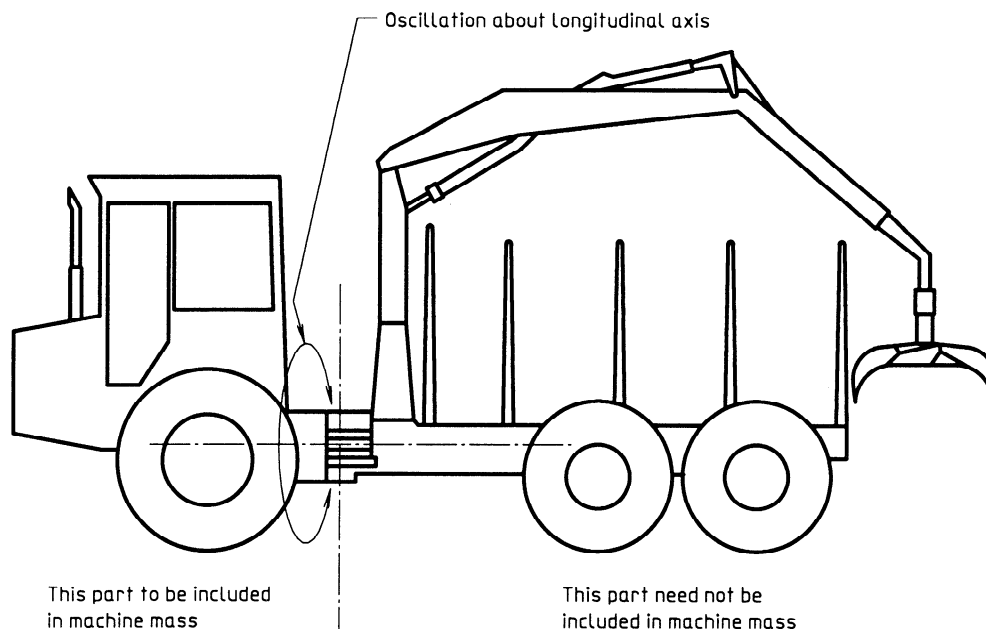

Figure 3 — Machine mass

iTeh STANDARD PREVIEW (standards.iteh.ai)

5.3 Apparatus

5.3.1 General

5.3.1.1 Assembly of ROPS to machine frame

The ROPS shall be attached to the machine frame as it would be on an operating machine. A complete machine is not required for the evaluation: however, the machine frame and ROPS mounting shall represent an operating installation. All normally detachable windows, panels, doors and other non-structural elements shall be removed so that they neither contribute to nor detract from the structural evaluation.

5.3.1.2 ROPS/machine attachment to bedplate

The ROPS/machine frame assembly shall be secured to the bedplate so that the members connecting the assembly and bedplate experience minimal deflection during testing. During lateral loading, the ROPS/machine frame assembly shall not receive any support from the bedplate, other than that due to the initial attachment.

Connections to the bedplate shall be directly from the machine frame at or near the front-axle support and the rear drive support. For articulated machines, if both frames are used in the evaluation, the hinge shall be locked so that the frames are in a straight line. If the frame on which the ROPS is mounted is used alone, the connections shall be at or near the extreme ends of the frame (see figure 4).

5.3.1.3 Elimination of energy absorbers

The assembly shall be secured and/or modified so that any machine element that might be considered as a suspension (rubber, gas, gas-oil or mechanical spring) shall be effectively eliminated as an energy absorber. However, the ROPS-structural members as defined in 3.1 may include suspension or flexible shock absorbers which shall not be altered.

5.3.2 Vertical loading, all machines

For vertical loading there is no limitation on securing or supporting the ROPS/machine frame assembly, except that no repair or straightening of the assembly shall be carried out.

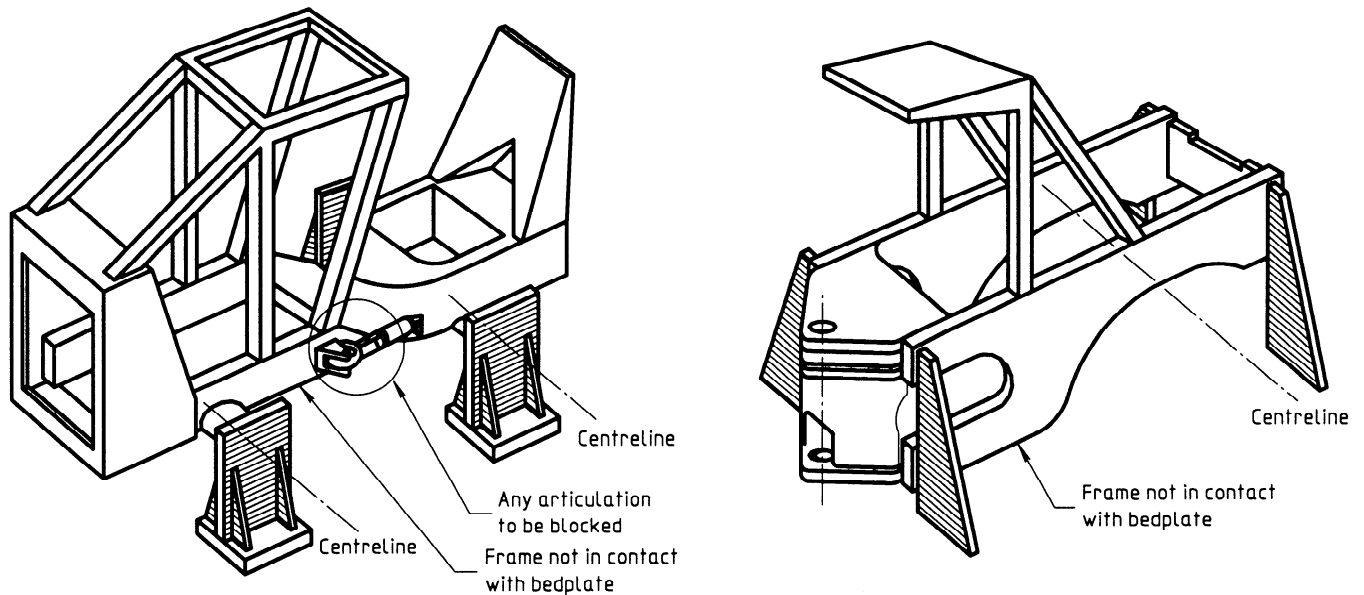

Figure 4 — Machine attachment to bedplate

5.4 Procedure

NOTE 2 The figures referred to in 5.4 are illustrative and are not intended to restrict the design of loading devices.

5.4.1 General

The test procedures shall consist of the operations specified in 5.4.2 and 5.4.3 in the order listed.

No repair or straightening of any ROPS/machine member shall be carried out during or between the lateral and vertical loading.

5.4.2 Lateral loading

5.4.2.1 The force-deflection characteristics shall be determined by lateral loading of the top major longitudinal members of the ROPS.

For a ROPS having more than two posts, the lateral loading shall be applied through a load-distribution device having a length not greater than 80 % of the horizontal distance, L , between the front and rear posts of the ROPS (see figure 5).

5.4.2.2 For a ROPS having a two-post system, the lateral loading shall be applied through a load-distribution device having a length not greater than 80 % of the horizontal distance L of the top longitudinal member of the ROPS at a distance $L/3$ from the rear main frame (see figure 6).

5.4.2.3 The initial direction of loading shall be horizontal and perpendicular to a vertical plane through the machine's longitudinal centreline. As loading continues, the ROPS/machine frame deformations may cause the direction of loading to change: this is permissible.

5.4.2.4 Should the operator's seat be off the machine's longitudinal centreline, the loading shall be against the outermost side nearest the seat. For on-centreline seats, if mounting of the ROPS is such that different force-deflection relations are obtained from loading from left or right, the side loaded shall be that which will place the most severe requirements on the ROPS/machine assembly.

5.4.2.5 The rate of application of deflection (load) shall be such that it can be considered static. At deflection increments no greater than 15 mm at the point of application of the resultant load, the force and deflection shall be recorded and plotted. The loading shall be continued until the ROPS has achieved both the force and energy requirements. The area under the resulting force-deflection curve equals the energy (see figure 7). The deflection(s) used in calculating energy shall be that of the ROPS along the line(s) of action of the force(s). Any deflection of members used to support load-application devices shall not be included in deflection measurements used for calculation of energy.