

INTERNATIONAL STANDARD

**ISO
8083**

First edition
1989-12-15

Machinery for forestry — Falling-object protective structures — Laboratory tests and performance requirements

iTeh STANDARD PREVIEW
(standards.iteh.ai)

*Matériel forestier — Structures de protection contre les chutes d'objets — Essais de
laboratoire et critères de performance*

[ISO 8083:1989](https://standards.iteh.ai/catalog/standards/sist/3edd4137-4e32-435c-8924-404562fc082d/iso-8083-1989)

[https://standards.iteh.ai/catalog/standards/sist/3edd4137-4e32-435c-8924-
404562fc082d/iso-8083-1989](https://standards.iteh.ai/catalog/standards/sist/3edd4137-4e32-435c-8924-404562fc082d/iso-8083-1989)



Reference number
ISO 8083 : 1989 (E)

Foreword

ISO (the International Organization for Standardization) is a worldwide federation of national standards bodies (ISO member bodies). The work of preparing International Standards is normally carried out through ISO technical committees. Each member body interested in a subject for which a technical committee has been established has the right to be represented on that committee. International organizations, governmental and non-governmental, in liaison with ISO, also take part in the work. ISO collaborates closely with the International Electrotechnical Commission (IEC) on all matters of electrotechnical standardization.

Draft International Standards adopted by the technical committees are circulated to the member bodies for approval before their acceptance as International Standards by the ISO Council. They are approved in accordance with ISO procedures requiring at least 75 % approval by the member bodies voting.

International Standard ISO 8083 was prepared by Technical Committee ISO/TC 23, *Tractors and machinery for agriculture and forestry*.

[ISO 8083:1989](https://standards.iteh.ai/catalog/standards/sist/3edd4137-4e32-435c-8924-4043621c062d/iso-8083-1989)

Annex A forms an integral part of this International Standard. Annex B is for information only.

© ISO 1989

All rights reserved. No part of this publication may be reproduced or utilized in any form or by any means, electronic or mechanical, including photocopying and microfilm, without permission in writing from the publisher.

International Organization for Standardization

Case postale 56 • CH-1211 Genève 20 • Switzerland

Printed in Switzerland

Machinery for forestry — Falling-object protective structures — Laboratory tests and performance requirements

1 Scope

This International Standard establishes a consistent, repeatable means of evaluating characteristics of falling-object protective structures (FOPS) under loading; it sets performance requirements for these structures under such loading in a representative test.

It applies to mobile or self-propelled specially-designed machines used in forestry as defined in ISO 6814.

2 Normative references

The following standards contain provisions which, through reference in this text, constitute provisions of this International Standard. At the time of publication, the editions indicated were valid. All standards are subject to revision, and parties to agreements based on this International Standard are encouraged to investigate the possibility of applying the most recent editions of the standards indicated below. Members of IEC and ISO maintain registers of currently valid International Standards.

ISO 898-1 : 1988, *Mechanical properties of fasteners — Part 1 : Bolts, screws and studs.*

ISO 898-2 : 1980, *Mechanical properties of fasteners — Part 2 : Nuts with specified proof load values.*

ISO 3164 : 1979, *Earth-moving machinery — Laboratory evaluations of roll-over and falling-object protective structures — Specifications for the deflection-limiting volume.*

ISO 3471-1 : 1986, *Earth-moving machinery — Roll-over protective structures — Laboratory tests and performance requirements — Part 1 : Crawler, wheel loaders and tractors, backhoe loaders, graders, tractor scrapers, articulated steer dumpers.*

ISO 6814 : 1983, *Machinery for forestry — Mobile and self-propelled machinery — Identification vocabulary.*

3 Definitions

For the purposes of this International Standard, the following definitions apply.

NOTE — The definitions are repeated, for the convenience of the user of this International Standard, from ISO 3449 : 1984.

3.1 roll-over protective structure (ROPS) : System of structural members arranged on a machine in such a way as to accomplish its primary purpose of reducing the possibility of an

operator, when wearing a seat belt, being crushed should his machine roll over. Structural members include any subframe, bracket, mounting, socket, bolt, pin suspension or flexible shock absorber used to secure the system to the machine frame but excludes mounting provisions which are integral with the machine frame.

3.2 deflection-limiting volume (DLV) : That volume, related to the operator, which serves to set limits and deflections permissible when performing laboratory evaluations of FOPS and ROPS. The volume, an approximation, is based on the seated dimensions of a large operator.

3.3 falling-object protective structure (FOPS) : System of structural members arranged in such a way as to provide operators with reasonable protection from falling objects (for example, trees, rocks).

4 Laboratory tests

4.1 Equipment

The items indicated in 4.1.1 to 4.1.5 will be needed.

4.1.1 Standard laboratory drop test object, made of steel, as shown in figure 1.

4.1.2 Means of raising the standard object to the required height.

4.1.3 Means of releasing the standard object so that it drops without restraint.

4.1.4 Hard surface, of such firmness that it is not penetrated by the vehicle or test bed under the loading of the drop test.

4.1.5 Measuring device, to determine whether the FOPS enters the deflection-limiting volume during the drop test.

4.2 Test conditions

4.2.1 DLV and location

The DLV and its location shall be in accordance with ISO 3164. The DLV should be fixed firmly to the same part of the machine as that to which the operator's seat is secured, and should remain there during the entire formal test period.

4.2.2 Measuring accuracy

The measuring device (4.1.5) used to measure the deflection of the FOPS shall be accurate to within $\pm 5\%$ of maximum deflection measured, or ± 1 mm.

4.2.3 Machine or test bed condition

4.2.3.1 The FOPS to be evaluated shall be attached to the machine structure as it would be in actual machine use. A complete machine is not required; however, the portion to which the FOPS is mounted shall be identical to the actual structure, and the vertical stiffness of any test bed used shall be not less than that of an actual machine as described in 4.2.3.2.

4.2.3.2 If the FOPS is mounted on a machine, the following requirements apply :

- a) there are no limitations on customary attachments and/or payload;
- b) all suspension systems, including pneumatic tyres, shall be set at operating levels; variable suspensions shall be in the maximum stiffness range;
- c) all cab elements, such as normally removable windows, panels or non-structural fittings, shall be removed so that they do not contribute to the strength of the FOPS.

4.3 Test procedure

The test procedure shall consist of the operations given in 4.3.1 to 4.3.5, in the order listed.

4.3.1 Place the standard laboratory drop test object (4.1.1), on the FOPS top (small end of the object down) at the location designated in 4.3.2.

4.3.2 The small end of the object shall be entirely within the vertical projection of the DLV, on the FOPS top. The centre of the object shall be at a point which depends on whether major, upper, horizontal members of the FOPS do or do not enter the vertical projection of the DLV on the upper part of the FOPS :

- Case 1 : When major, upper, horizontal members of FOPS do not enter the vertical projection of the DLV on the upper part of the FOPS.

The centre of the drop test object shall be at that point which has the greatest possible sum of perpendicular distances ($x + y$ in figure 2) from the major, upper, horizontal structural members.

- Case 2 : When major, upper, horizontal members do enter the vertical projection of the DLV on the upper part of the FOPS.

Where the covering material of all the surface areas above the operator is the same but of unknown thickness, the centre of the drop test object shall be in the surface of greatest area. This area is the projected area of the DLV without major, upper, horizontal members. The centre of

the drop test object shall be at that point, within the surface of greatest area, which has the greatest possible sum of perpendicular distances ($x + y$ in figure 2) from the major, upper, horizontal structural members.

Where different materials are used in different areas above the operator, each area in turn shall be subjected to a drop test.

4.3.3 Raise the drop test object vertically to a height above the position indicated in 4.3.1 and 4.3.2 to develop an energy of 5 800 J or 11 600 J based on the mass of an object shaped as shown in figure 1. Two energy levels are given : national authorities may choose the level of requirement according to local conditions such as log size, etc. The drop test object shall be aimed to impact at a location on the FOPS to produce the maximum deflection.

4.3.4 Release the drop test object so that it falls freely onto the FOPS.

4.3.5 As it is unlikely that the free fall will result in the drop test object hitting at the location and/or in the attitude of 4.3.1 and 4.3.2, the limits given in 4.3.5.1 to 4.3.5.3 are placed on deviations.

4.3.5.1 The initial impact of the small end of the drop test object shall be entirely within a circle of 200 mm radius (the centre of this circle is to coincide with the vertical centre line of the drop test object as positioned according to 4.3.1 and 4.3.2) but not on any major, upper, horizontal member.

4.3.5.2 The first contact between the drop test object and the FOPS shall only be along the small end of the drop test object and/or the radius contiguous to that end (see figure 1).

4.3.5.3 There is no limitation on location or attitude of subsequent impacts due to rebound.

5 Performance requirements

5.1 Protective properties

The protective properties of the FOPS system shall be estimated by the ability of the cabin or protective structure to retain its safety zone intact after the impact. The DLV as defined in 3.2 and specified in 4.2.1 shall not be entered by any part of the protective structure under the first or subsequent impact of the drop test object. If the drop test object penetrates the DLV, the FOPS shall be deemed to have failed.

5.2 Additional ROPS requirements

Where the structure is intended to fulfil both ROPS and FOPS requirements, it shall also meet the performance requirements for the appropriate ROPS as given in ISO 3471-1. Where roll-over protection is not required, a different structure may be used to support the FOPS as long as the DLV is not entered in the test.

Should the same structure be used for both ROPS and FOPS evaluations, the drop test procedure shall precede the ROPS loading : the removal of impact dents or replacement of the FOPS cover is permitted.

NOTE — It is not required that the included volume of a ROPS and FOPS having four or more vertical members entirely enclose the DLV. Nor is it intended that a simple (two-post) frame be excluded as either a FOPS or ROPS.

5.3 Temperature/material requirements

5.3.1 Laboratory evaluations shall be performed with FOPS and machine frame members soaked to $-18\text{ }^{\circ}\text{C}$ or below.

5.3.2 If the evaluations are not performed at this temperature, the following minimum material requirements shall be met.

5.3.2.1 Bolts and nuts used to attach the FOPS (or FOPS cover and its supporting structure) to the machine frame and to connect structural parts to the FOPS cover shall be property class 8.8 or 10.9 bolts and property class 8 or 10 nuts as given in ISO 898-1 and ISO 898-2 respectively.

5.3.2.2 Structural members of the FOPS and ROPS (or FOPS cover) and the mounts which attach them to the machine frame shall be made from steels or equivalent materials that have one of the following Charpy V-notch impact strengths, at $-30\text{ }^{\circ}\text{C}$:

- 10 mm × 10 mm specimen : 10,8 J
- 10 mm × 7,5 mm specimen : 9,5 J

— 10 mm × 5 mm specimen : 7,5 J

— 10 mm × 2,5 mm specimen : 5,5 J

Specimens shall be longitudinal and taken from flat stock, tubular, or structural sections before forming or welding for use in FOPS. Specimens from tubular or structural sections shall be taken from the middle of the biggest side and not include welds.

In those countries using the inch system, the grade of the bolts and nuts used shall be equivalent, as given in national standards, to the FOPS material grade.

NOTE — The requirements of 5.3.2.2 are given as information until such time as an International Standard is developed.

5.3.3 Apparatus used shall be finished to eliminate sharp corners and edges adjacent to operator or service personnel work areas.

6 Test report

The test report shall include the results of the test and be presented in a typical test report in accordance with annex A. Additional information, as presented in annex B shall be reported only to the originator of the test request.

<https://standards.iteh.ai/catalog/standards/sist/3edd4137-4e32-435c-8924-404562fc082d/iso-8083-1989>

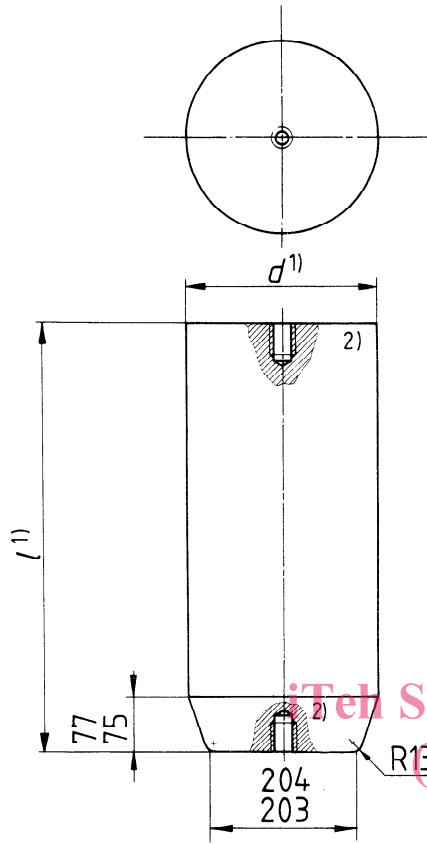

1) Dimensions d and l are optional, depending on the mass of the test object required to match the drop height that will provide the energy specified in 4.3.3.

For example, for a drop test object mass of 227 kg :

$d = 255$ to 260

$l = 583$ to 585

2) May be drilled and tapped for a lifting eye.

STANDARD PREVIEW
standards.iteh.ai)

ISO 8083:1989

<https://standards.iteh.ai/catalog/standards/sist/3edd4137-4e32-435c-8924-404562fc082d/iso-8083-1989>

Figure 1 — Standard laboratory drop test object

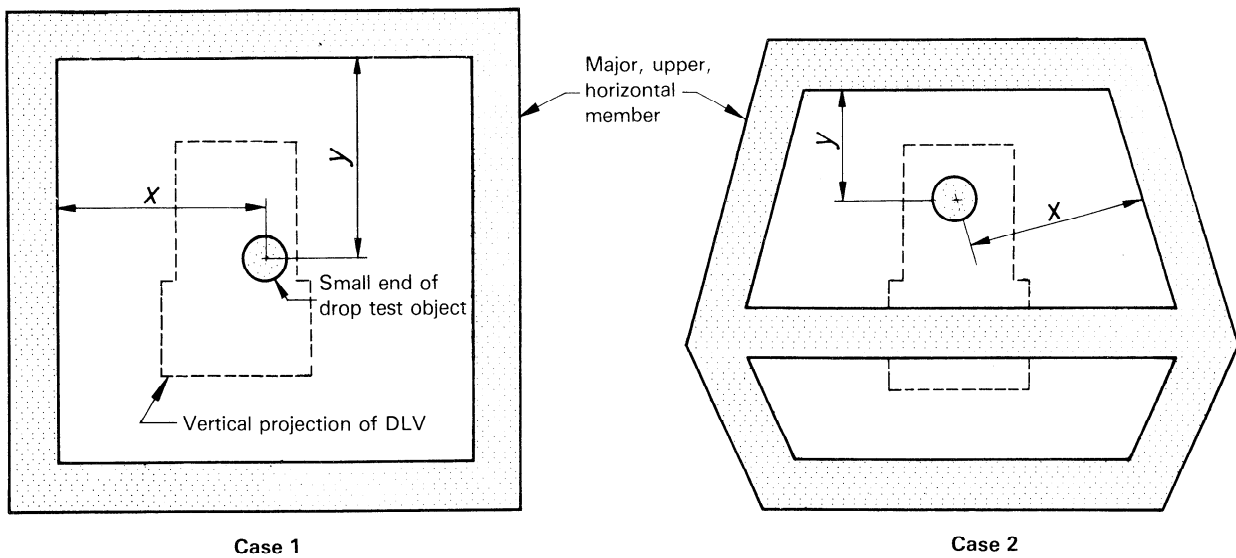

Case 1

Case 2

Figure 2 — Drop test impact points

Annex A
(normative)

Standard test report

(See clause 6)

A.1 Identification

A.1.1 Machine(s)

Type:

Manufacturer:

Model:

Serial number (if any):

Machine (frame part number):

A.1.2 FOPS

Manufacturer:

Model:

Serial number (if any):

FOPS (may include ROPS) part number:

A.2 Information supplied by manufacturer(s)

Location of DLV:

A.3 Conclusion

Confirm the test results by the following:

- a) The minimum performance requirements of ISO 8083 were met (not met) in this test.
- b) Date of test.
- c) Name and address of the test facility.
- d) Tested by (signature).
- e) Date of report.

iTeh STANDARD PREVIEW
(standards.iteh.ai)

<https://standards.iteh.ai/catalog/standards/sist/3edd4137-4e32-435c-8924-404562fc082d/iso-8083-1989>

Annex B
(informative)

Test report — Additional information for originator of test request

(See clause 6)

B.1 Drop test object

B.1.1 Standard:

- diameter: mm
- length: mm
- mass: kg

B.1.2 Height of fall for the test m

B.2 Photographs

B.2.1 One photograph of drop test object and test arrangement before application of drop test(s).

B.2.2 Photographs as necessary to show top and bottom of FOPS structure after application of drop test(s)

B.3 Test results

B.3.1 Drop test

Energy imparted by drop test objects with no penetration by any part of the FOPS structure into the DLV nor penetration of the FOPS by the drop test object.

..... J

B.3.2 Material temperature

a) The test performed with FOPS and machine frame members soaked to °C or verification of the Charpy V-notch impact strength requirements for FOPS and ROPS (or FOPS cover) structural metallic members.

b) Verification of the property class requirements for bolts and nuts (see 5.3.2.1).

ITEH STANDARD PREVIEW
(standards.iteh.ai)
<https://standards.iteh.ai/catalog/standards/sist/3edd4137-4e32-435c-8924-404562fc082d/iso-8083-1989>

UDC 630 : 62-783 : 620.1

Descriptors : forest equipment, safety devices, protection against falling objects, specifications, tests, laboratory tests.

Price based on 6 pages
