



SLOVENSKI STANDARD
SIST EN ISO 19958:2005

01-marec-2005

Obutev – Preskusne metode za pete in napetnike – Vzdržljivost napetnika (ISO 19958:2004)

Footwear - Test methods for heels and top pieces - Top piece retention strength (ISO 19958:2004)

Schuhe - Prüfverfahren für Absätze und Oberflecken - Haltefestigkeit von Oberflecken (ISO 19958:2004)

Chaussures - Méthodes d'essai relatives aux talons et aux bonbouts - Force de rétention du bonbout (ISO 19958:2004)

Ta slovenski standard je istoveten z: EN ISO 19958:2004

ICS:

61.060

Obuvala

Footwear

SIST EN ISO 19958:2005

en

iTeh STANDARD PREVIEW
(standards.iteh.ai)

SIST EN ISO 19958:2005

<https://standards.iteh.ai/catalog/standards/sist/3aa33614-c72e-4932-9a6a-469b6b45b1d3/sist-en-iso-19958-2005>

EUROPEAN STANDARD

EN ISO 19958

NORME EUROPÉENNE

EUROPÄISCHE NORM

September 2004

ICS 61.060

English version

Footwear - Test methods for heels and top pieces - Top piece retention strength (ISO 19958:2004)

Chaussures - Méthodes d'essai relatives aux talons et aux
bonbouts - Force de rétention du bonbout (ISO
19958:2004)

Schuhe - Prüfverfahren für Absätze und Oberflecken -
Haltefestigkeit von Oberflecken (ISO 19958:2004)

This European Standard was approved by CEN on 16 January 2004.

CEN members are bound to comply with the CEN/CENELEC Internal Regulations which stipulate the conditions for giving this European Standard the status of a national standard without any alteration. Up-to-date lists and bibliographical references concerning such national standards may be obtained on application to the Central Secretariat or to any CEN member.

This European Standard exists in three official versions (English, French, German). A version in any other language made by translation under the responsibility of a CEN member into its own language and notified to the Central Secretariat has the same status as the official versions.

CEN members are the national standards bodies of Austria, Belgium, Cyprus, Czech Republic, Denmark, Estonia, Finland, France, Germany, Greece, Hungary, Iceland, Ireland, Italy, Latvia, Lithuania, Luxembourg, Malta, Netherlands, Norway, Poland, Portugal, Slovakia, Slovenia, Spain, Sweden, Switzerland and United Kingdom.

[SIST EN ISO 19958:2005](https://standards.iteh.ai/catalog/standards/sist/3aa33614-c72e-4932-9a6a-469b6b45b1d3/sist-en-iso-19958-2005)

<https://standards.iteh.ai/catalog/standards/sist/3aa33614-c72e-4932-9a6a-469b6b45b1d3/sist-en-iso-19958-2005>



EUROPEAN COMMITTEE FOR STANDARDIZATION
COMITÉ EUROPÉEN DE NORMALISATION
EUROPÄISCHES KOMITEE FÜR NORMUNG

Management Centre: rue de Stassart, 36 B-1050 Brussels

Contents	page
Foreword.....	3
1 Scope	4
2 Normative references	4
3 Terms and definitions	4
4 Apparatus and materials	4
5 Sampling and conditioning.....	4
5.1 General.....	4
5.2 Preparation	5
6 Test method.....	8
6.1 Principle.....	8
6.2 Procedure	9
7 Expression of results	9
8 Test report	9

iTeh STANDARD PREVIEW
(standards.iteh.ai)

[SIST EN ISO 19958:2005](https://standards.iteh.ai/catalog/standards/sist/3aa33614-c72e-4932-9a6a-469b6b45b1d3/sist-en-iso-19958-2005)

<https://standards.iteh.ai/catalog/standards/sist/3aa33614-c72e-4932-9a6a-469b6b45b1d3/sist-en-iso-19958-2005>

Foreword

This document (EN ISO 19958:2004) has been prepared by Technical Committee CEN /TC 309 "Footwear", the secretariat of which is held by AENOR, in collaboration with Technical Committee ISO/TC 216 "Footwear".

This European Standard shall be given the status of a national standard, either by publication of an identical text or by endorsement, at the latest by March 2005, and conflicting national standards shall be withdrawn at the latest by March 2005.

According to the CEN/CENELEC Internal Regulations, the national standards organizations of the following countries are bound to implement this European Standard: Austria, Belgium, Cyprus, Czech Republic, Denmark, Estonia, Finland, France, Germany, Greece, Hungary, Iceland, Ireland, Italy, Latvia, Lithuania, Luxembourg, Malta, Netherlands, Norway, Poland, Portugal, Slovakia, Slovenia, Spain, Sweden, Switzerland and United Kingdom.

iTeh STANDARD PREVIEW (standards.iteh.ai)

[SIST EN ISO 19958:2005](https://standards.iteh.ai/catalog/standards/sist/3aa33614-c72e-4932-9a6a-469b6b45b1d3/sist-en-iso-19958-2005)

<https://standards.iteh.ai/catalog/standards/sist/3aa33614-c72e-4932-9a6a-469b6b45b1d3/sist-en-iso-19958-2005>

EN ISO 19958:2004 (E)

1 Scope

This European Standard specifies a test method for measuring the force required to detach the top piece from the underside of the shoe heel. The test is applicable to heels with the top piece already attached which have been removed from complete shoes, to heels alone with the top piece attached and, in some instances, to heels with separate push-in top pieces. All heels, except reinforced slender heels with top pieces attached by steel spigots and built stacked heels, can be tested by this method.

2 Normative references

The following referenced document is indispensable for the application of this document. For dated references, only the edition cited applies. For undated references, the latest edition of the referenced document (including any amendments) applies.

EN ISO 7500-1 *Metallic materials - Verification of static uniaxial testing machines - Part 1: Tension/compression testing machines (ISO 7500-1:1999)*.

3 Terms and definitions

For the purposes of this European Standard, the following term and definition apply.

top piece retention strength

maximum force, expressed in Newton, required to pull off a top piece from the heel

4 Apparatus and materials

4.1 The following apparatus and materials shall be used.

4.2 **Tensile testing machine**, complying with the requirements of EN ISO 7500-1 class 2, with a range of 0 N to 1000 N and a constant-rate-of-loading of 15 N/s \pm 5 N/s. A constant-rate-of-traverse tester, for which increase of force produces an appreciable movement of the load jaw (e.g. a "pendulum" tester), may be used if the rate of traverse is set to give, on average, the specified rate of force application when a test is carried out. Alternatively, a constant-rate-of-traverse tester for which there is little movement on the load jaw may be used if the top piece is attached to one jaw of the tester via one or more extensible cords which are substantially elastic over the force range of the test and the rate of traverse is adjusted until the specified rate of force application is obtained.

4.3 **Drill**, with twist drill beats of suitable sizes (see 5.2.1.4 and 5.2.1.5).

4.4 **Bolt**, of size M 4 or size M 3 for slender heels, and preferably of length 40 mm or more with a small metal ring or loop attached to its head by brazing. If only low heels are being tested, however, the bolt need not be longer than about 20 mm.

4.5 **Rod**, of diameter 2 mm and appropriate length or one or more strong extensible cords, e.g. nylon shoes laces.

5 Sampling and conditioning

5.1 General

The form of the test piece needs to be varied according to the height of the heels. For medium and high heels the type of test piece shown in Figure 1 is convenient, in which the heel is held by one cord or rod. For heels of less than about 20 mm in height this cord is likely to interfere with the bolt attached to the top piece. In such cases the form of attachment shown in Figure 2 should be used.

5.2 Preparation

5.2.1 Medium and high heels

5.2.1.1 The prepared test piece is illustrated in Figure 1.

5.2.1.2 It is permissible to test heels and top pieces supplied separately, provided the top piece can be attached in the laboratory by essentially the same method as in production. Push-in top pieces shall be inserted fully by pneumatic pressure. Some types of these top pieces are additionally attached by short nails inserted through holes moulded in the top piece. This also may be inserted in the laboratory, by hammering or pneumatic pressure, but the correct nail shall be used. The top piece may be attached by staples using a staple gun provided the staples are the same as those used in production.

The attachment of the top piece may precede or follow the other details of the preparation described in 5.2.1.3, 5.2.1.4 and 5.2.1.5.

5.2.1.3 Cut through the heel stem parallel to the top piece and approximately 30 mm from it, in order to gain access to the cavity and inner side of the top piece or top piece spigot. This may be done with the heel still attached to the shoe or, if preferred, the heel may be detached first by removing the heel attaching pins. For fairly low heels the amount cut off may be reduced to approximately 20 mm provided there is still enough room for the bolt (see 6.2.2). Otherwise the procedure for low heels described in 5.2 should be used. In the case of heels having the "Autoloc" type of top piece attachment which do not have a full height centre cavity in the stem, it is necessary to drill a hole down the centre of the stem from the cut surface to the "Autoloc" cavity or recess on the underside of the heel. The diameter of this hole should be not less than 10 mm.

5.2.1.4 Drill a hole vertically through the centre of the top piece just large enough to accommodate a suitable bolt of the type described in 4.4.

5.2.1.5 Drill the heel stem horizontally from one side to the other approximately 5 mm above the cut surface, as shown in Figure 1, so that the drilled hole, which should be large enough to take the rod or cord described in 4.5, is parallel to the heel breast and passes through the vertical centreline of the top piece.

5.2.2 Low heels

5.2.2.1 The prepared test piece is shown in Figure 2. Where the heel is attached to a shoe, remove it by extracting the heel attaching pins.

5.2.2.2 Cut out any rib or ribs across the centre cavity in the heel, taking care not to damage the top piece when doing this.

5.2.2.3 Drill a hole vertically through the centre of the top piece just large enough to accommodate a suitable bolt of the type described in 4.4.

5.2.2.4 Drill two holes horizontally through the heel from one side to the other, large enough to take the cord described in 4.5. They shall be parallel to the heel breast, approximately 6 mm from the heel/top piece interface and approximately 12 mm on each side of the centre of the top piece.

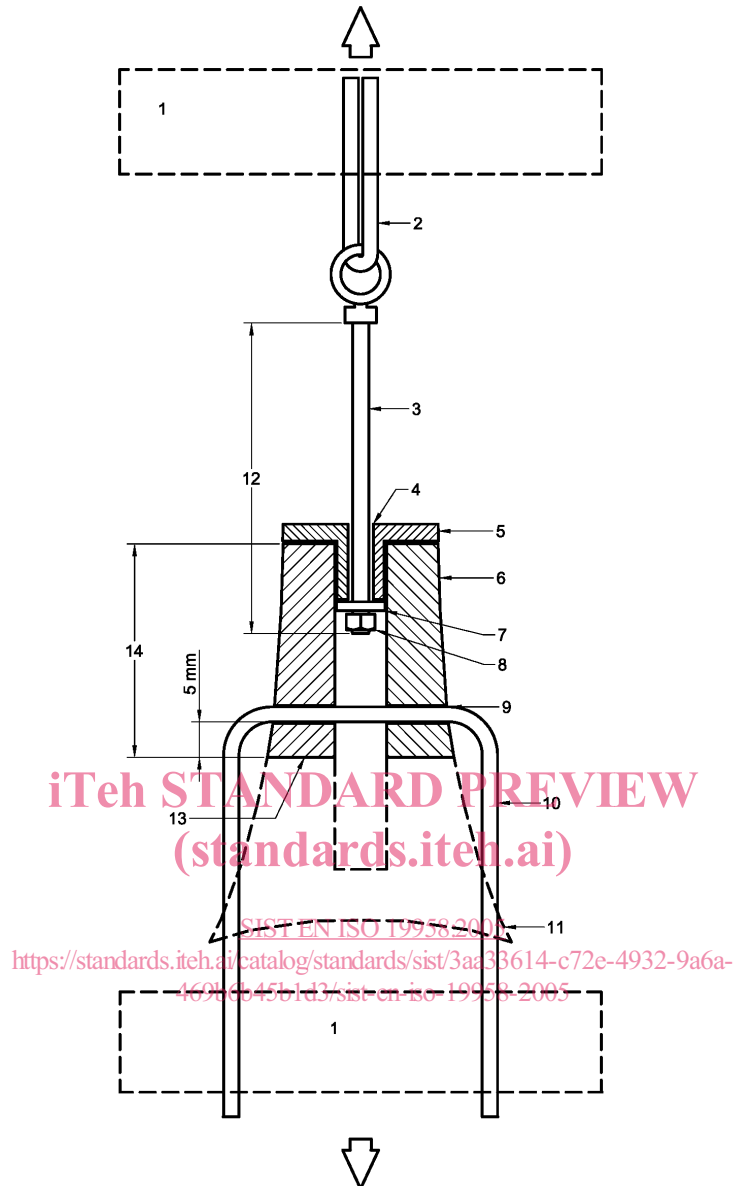

Key

- 1 Tensile machine jaw
- 2 Rod to top jaw
- 3 Bolt
- 4 Drilled hole in top-piece for bolt
- 5 Top-piece
- 6 Heel
- 7 Washer
- 8 Nut
- 9 Drilled hole for rod or cord
- 10 Rod or cord to bottom jaw
- 11 Part of heel not required for test
- 12 At least 40 mm
- 13 Heel cut along this line
- 14 Approximately 30 mm

Figure 1 — Testing of high and medium heels. Side view of testing assembly and section through heel

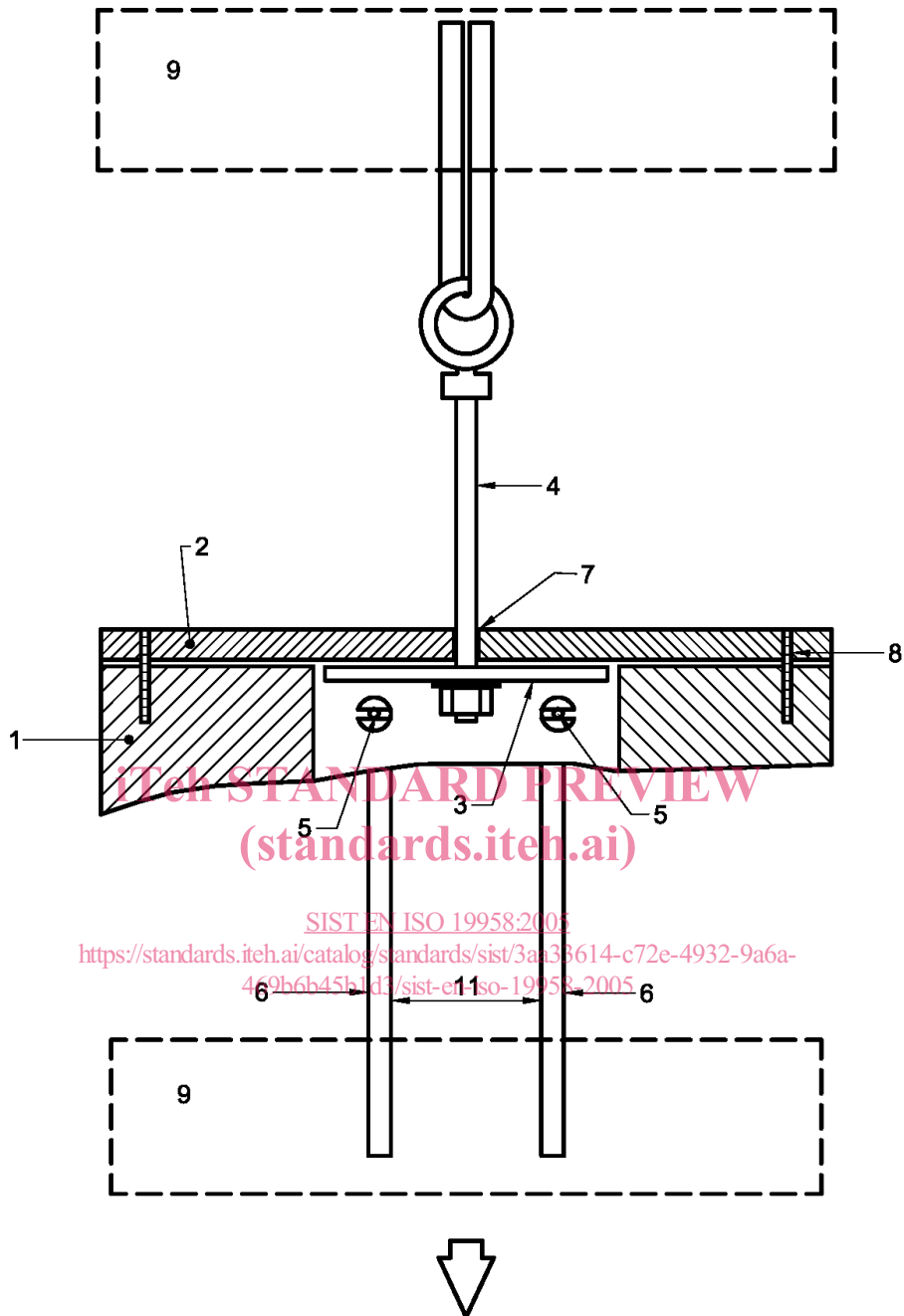

Figure 2a - Side view of test assembly and section through heel and top piece in the heel/toe direction