



SLOVENSKI STANDARD
SIST EN ISO 19953:2004

01-oktober-2004

Footwear - Test methods for heels - Resistance to lateral impact (ISO 19953:2004)

Footwear - Test methods for heels - Resistance to lateral impact (ISO 19953:2004)

Schuhe - Prüfverfahren für Absätze - Widerstand gegen seitlichen Schlag (ISO 19953:2004)

Chaussures - Méthodes d'essai relatives aux talons - Résistance aux chocs latéraux (ISO 19953:2004)

ITeH STANDARD PREVIEW
(standards.iteh.ai)

Ta slovenski standard je istoveten z: EN ISO 19953:2004

SIST EN ISO 19953:2004
<https://standards.iteh.ai/catalog/standards/sist/9379-f01f12614c90/sist-en-iso-19953-2004>

ICS:

61.060

Obuvala

Footwear

SIST EN ISO 19953:2004

en

iTeh STANDARD PREVIEW
(standards.iteh.ai)

SIST EN ISO 19953:2004

<https://standards.iteh.ai/catalog/standards/sist/9397281e-7462-4941-9379-f01f12614c90/sist-en-iso-19953-2004>

EUROPEAN STANDARD
NORME EUROPÉENNE
EUROPÄISCHE NORM

EN ISO 19953

July 2004

ICS 61.060

English version

**Footwear - Test methods for heels - Resistance to lateral impact
(ISO 19953:2004)**

Chaussures - Méthodes d'essai relatives aux talons -
Résistance aux chocs latéraux (ISO 19953:2004)

Schuhe - Prüfverfahren für Absätze - Widerstand gegen
seitlichen Schlag (ISO 19953:2004)

This European Standard was approved by CEN on 10 December 2003.

CEN members are bound to comply with the CEN/CENELEC Internal Regulations which stipulate the conditions for giving this European Standard the status of a national standard without any alteration. Up-to-date lists and bibliographical references concerning such national standards may be obtained on application to the Central Secretariat or to any CEN member.

This European Standard exists in three official versions (English, French, German). A version in any other language made by translation under the responsibility of a CEN member into its own language and notified to the Central Secretariat has the same status as the official versions.

CEN members are the national standards bodies of Austria, Belgium, Cyprus, Czech Republic, Denmark, Estonia, Finland, France, Germany, Greece, Hungary, Iceland, Ireland, Italy, Latvia, Lithuania, Luxembourg, Malta, Netherlands, Norway, Poland, Portugal, Slovakia, Slovenia, Spain, Sweden, Switzerland and United Kingdom.

[SIST EN ISO 19953:2004](https://standards.iteh.ai/catalog/standards/sist/9397281e-7462-4941-9379-f01f12614c90/sist-en-iso-19953-2004)

<https://standards.iteh.ai/catalog/standards/sist/9397281e-7462-4941-9379-f01f12614c90/sist-en-iso-19953-2004>



EUROPEAN COMMITTEE FOR STANDARDIZATION
COMITÉ EUROPÉEN DE NORMALISATION
EUROPÄISCHES KOMITEE FÜR NORMUNG

Management Centre: rue de Stassart, 36 B-1050 Brussels

Contents

	page
Foreword.....	3
1 Scope	4
2 Apparatus and material	4
2.1 General.....	4
2.2 Lateral impact tester.....	4
2.3 Metal mounting trays.....	6
2.4 Metal alloy.....	6
3 Sampling and conditioning.....	6
4 Test method.....	6
4.1 Principle.....	6
4.2 Procedure	7
5 Expression of results	7
6 Test report	7

[SIST EN ISO 19953:2004](https://standards.iteh.ai/catalog/standards/sist/9397281e-7462-4941-9379-f01f12614c90/sist-en-iso-19953-2004)
<https://standards.iteh.ai/catalog/standards/sist/9397281e-7462-4941-9379-f01f12614c90/sist-en-iso-19953-2004>

Foreword

This document (EN ISO 19953:2004) has been prepared by Technical Committee CEN /TC 309, "Footwear", the secretariat of which is held by AENOR, in collaboration with ISO/TC 216 "Footwear".

This European Standard shall be given the status of a national standard, either by publication of an identical text or by endorsement, at the latest by January 2005, and conflicting national standards shall be withdrawn at the latest by January 2005.

According to the CEN/CENELEC Internal Regulations, the national standards organizations of the following countries are bound to implement this European Standard: Austria, Belgium, Cyprus, Czech Republic, Denmark, Estonia, Finland, France, Germany, Greece, Hungary, Iceland, Ireland, Italy, Latvia, Lithuania, Luxembourg, Malta, Netherlands, Norway, Poland, Portugal, Slovakia, Slovenia, Spain, Sweden, Switzerland and United Kingdom.

iTeh STANDARD PREVIEW (standards.iteh.ai)

[SIST EN ISO 19953:2004](https://standards.iteh.ai/catalog/standards/sist/9397281e-7462-4941-9379-f01f12614c90/sist-en-iso-19953-2004)

<https://standards.iteh.ai/catalog/standards/sist/9397281e-7462-4941-9379-f01f12614c90/sist-en-iso-19953-2004>

EN ISO 19953:2004 (E)

1 Scope

This European Standard specifies a test method for determining the impact strength of the heels of ladies' shoes. The result provides an assessment of the liability to failure under the occasional heavy blows received during wear.

NOTE While the test method is applicable to all types of high heels, of whatever construction, it is particularly useful for injection-moulded plastics heels which incorporate a steel dowel reinforcement, giving information on the suitability of the dowels' hardness or softness. Normally, heels which by virtue of their shape have a high lateral impact resistance do not need to be tested in this way.

2 Apparatus and material

2.1 General

The following apparatus and material shall be used.

2.2 Lateral impact tester

2.2.1 General

An example of a suitable apparatus is being shown in Figure 1. The apparatus is clamped either onto a solid built-in bench, or onto a rigid free-standing frame anchored to the floor.

The lateral impact tester shall include the following.

2.2.2 Pendulum, consisting of a circular steel bob of diameter (108 ± 1) mm and thickness (49 ± 2) mm, which is fixed by a circular steel shaft of diameter $(25 \pm 0,5)$ mm to a hub, on the bearing axle of diameter (75 ± 1) mm. The distance from the centre of the bob to the centre of the hub is (432 ± 2) mm. The moment of the pendulum when it is held horizontally is $(17,3 \pm 0,2)$ N·m.

2.2.3 Striker head, consisting of a strip of metal $(6,0 \pm 0,5)$ mm thick, $(25,0 \pm 0,5)$ mm wide and (35 ± 2) mm long with the striking edge rounded to a radius of $(3,0 \pm 0,5)$ mm. The head is fixed rigidly to the pendulum bob so that the striker tip and centre of the bob lie on the same circle of swing of the pendulum and are (89 ± 2) mm apart.

2.2.4 Energy scale for the pendulum, calibrated in increment of 0,68 J, from 0 J to 18,3 J. A marker attached to the pendulum moves over this scale and enables the pendulum to be set up to the desired energy of blow.

2.2.5 Base clamp, for holding the metal mounting tray (3.2) and for adjusting it vertically and horizontally to achieve correct alignment of the heel tip.

NOTE If the apparatus is not firmly mounted there is partial loss of energy on impact, thereby producing false results.

Dimensions in millimetres

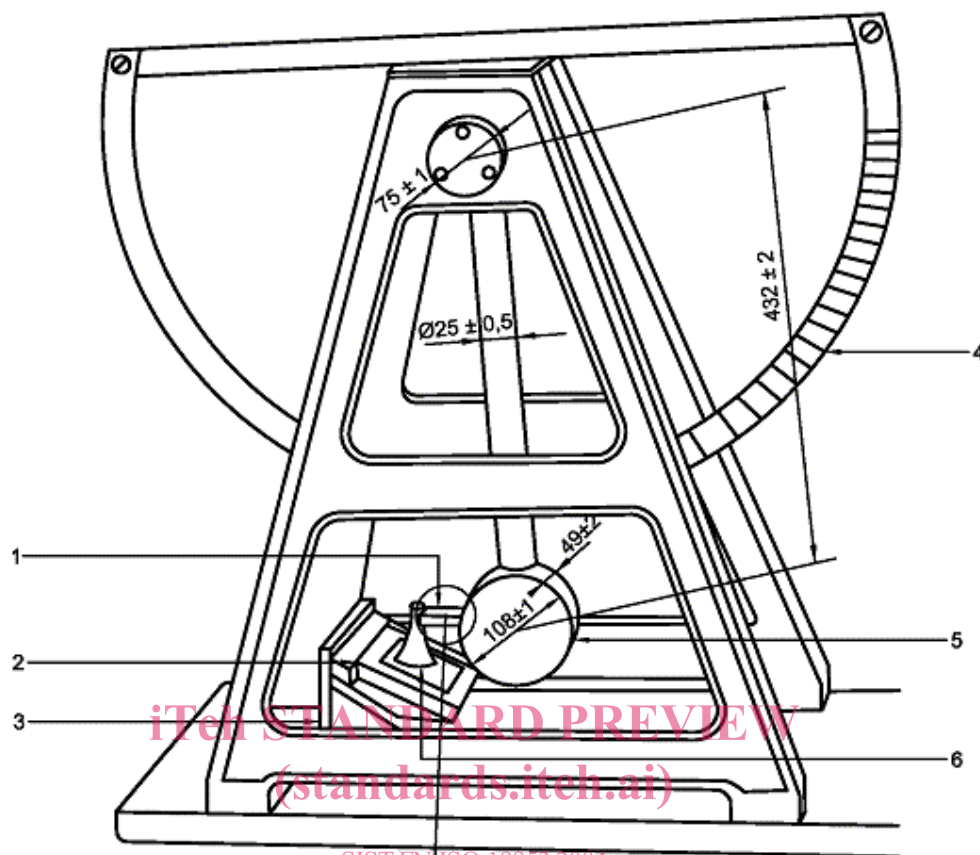

SIST EN ISO 19953:2004

<https://standards.itech.ai/catalog/standards/sist/9397281e-7462-4941-9379-f01f12614c90/sist-en-iso-19953-2004>

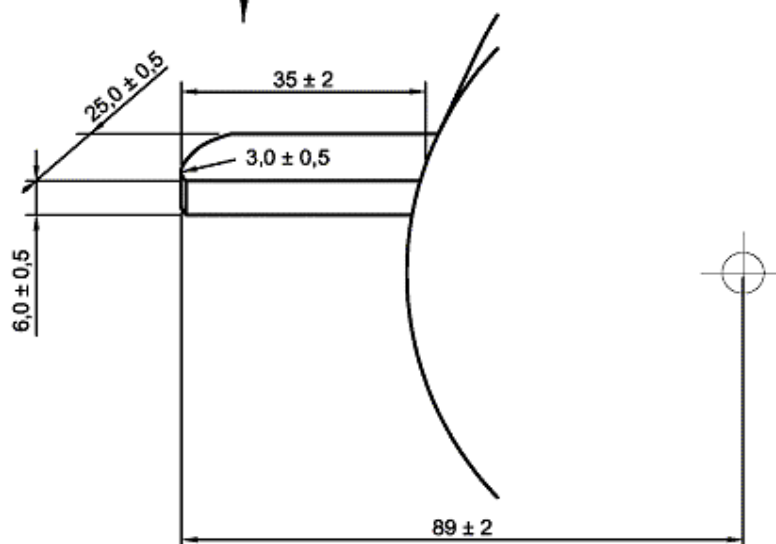
**Key**

- | | | | |
|---|--------------|---|---------------|
| 1 | Striker head | 4 | Energy scale |
| 2 | Heel tray | 5 | Pendulum |
| 3 | Base clamp | 6 | Test specimen |

Figure 1 — Lateral impact tester

EN ISO 19953:2004 (E)

2.3 Metal mounting trays

An example of a suitable apparatus is shown in Figure 2. Each to contain a heel set in metal alloy of melting point between 100° C and 150° C.

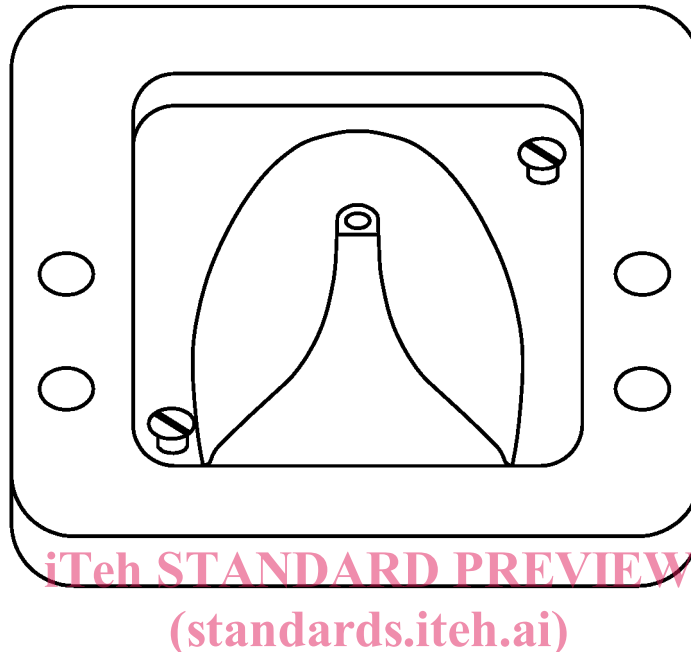

Figure 2 — Metal mounting tray with heel in position before addition of molten alloy

[SIST EN ISO 19953:2004](https://standards.iteh.ai/catalog/standards/sist/9397281e-7462-4941-9379-f01f12614c90/sist-en-iso-19953-2004)

2.4 Metal alloy

<https://standards.iteh.ai/catalog/standards/sist/9397281e-7462-4941-9379-f01f12614c90/sist-en-iso-19953-2004>

Melting point between 100° C and 150° C.

3 Sampling and conditioning

3.1 Take free heels and set each heel in a dry metal mounting tray (3.2), using the procedure described in 3.2 or, for very short heel (usually those below 40 mm in height), the procedure described in 3.3, to obtain a test specimen assembly.

3.2 Place the heel centrally in the tray so that the seat breast edge is against a flat end of the tray and the heel tip points upwards (see Figure 2). Heat the metal alloy (3.3) until it is at the lowest temperature at which it will flow into all parts of the tray, filling the space around the heel to within 3 mm from the top. Allow the alloy to cool and set thereby providing a rigid mounting for the heel.

3.3 Since some very short heels cannot be struck correctly by the striker if mounted in accordance with 4.2 (because the bottom of the pendulum catches the base clump assembly), a different method of mounting is necessary. In such cases mount the heel with the rear of the heel seat against a flat end of the tray. Cut a small amount from the rear of the heel so as to set the heel further towards the rear of the mounting tray if this allows the striker to strike the heel correctly.

4 Test method

4.1 Principle

A heel, clamped with the tip uppermost and the stem approximately vertical, is subjected repeatedly to measured blows from a pendulum striker, the energy of the blows increasing successively until the heel fails.