



SLOVENSKI STANDARD
SIST ISO 8133:1998
01-december-1998

Fluidna tehnika - Hidravlika - Valji z enostransko batnico kompaktne vrste 16 MPa (160 barov) - Vgradne mere pribora

Hydraulic fluid power -- Single rod cylinders, 16 MPa (160 bar) compact series -- Accessory mounting dimensions

iTeh STANDARD PREVIEW

Transmissions hydrauliques -- Vérins 16 MPa (160 bar) à simple tige, série compacte -- Dimensions d'interchangeabilité des accessoires

[SIST ISO 8133:1998](https://standards.iteh.ai/catalog/standards/sist/a492ddb-3176-4d97-a886-0d44e27d7d6b/sist-iso-8133-1998)

Ta slovenski standard je istoveten z: ISO 8133:1991

ICS:

23.100.20 Pomožna oprema Cylinders

SIST ISO 8133:1998 en

iTeh STANDARD PREVIEW
(standards.iteh.ai)

SIST ISO 8133:1998

<https://standards.iteh.ai/catalog/standards/sist/a492ddb-3176-4d97-a886-0d44e27d7d6b/sist-iso-8133-1998>

INTERNATIONAL STANDARD

ISO
8133

First edition
1991-09-15

Hydraulic fluid power — Single rod cylinders, 16 MPa (160 bar) compact series — Accessory mounting dimensions

iTeh STANDARD PREVIEW

(Standards.iteh.ai)
*Transmissions hydrauliques — Vérins 16 MPa (160 bar) à simple tige,
série compacte — Dimensions d'interchangeabilité des accessoires*

[SIST ISO 8133:1998](https://standards.iteh.ai/catalog/standards/sist/a492dddb-3176-4d97-a886-0d44e27d7d6b/sist-iso-8133-1998)

<https://standards.iteh.ai/catalog/standards/sist/a492dddb-3176-4d97-a886-0d44e27d7d6b/sist-iso-8133-1998>



Reference number
ISO 8133:1991(E)

ISO 8133:1991(E)

Foreword

ISO (the International Organization for Standardization) is a worldwide federation of national standards bodies (ISO member bodies). The work of preparing International Standards is normally carried out through ISO technical committees. Each member body interested in a subject for which a technical committee has been established has the right to be represented on that committee. International organizations, governmental and non-governmental, in liaison with ISO, also take part in the work. ISO collaborates closely with the International Electrotechnical Commission (IEC) on all matters of electrotechnical standardization.

Draft International Standards adopted by the technical committees are circulated to the member bodies for voting. Publication as an International Standard requires approval by at least 75% of the member bodies casting a vote.

International Standard ISO 8133 was prepared by Technical Committee ISO/TC 131, *Fluid power systems*, Sub-Committee SC 3, *Cylinders*.

[SIST ISO 8133:1998](https://standards.iteh.ai/catalog/standards/sist/a492dddb-3176-4d97-a886-0d44e27d7d6b/sist-iso-8133-1998)

<https://standards.iteh.ai/catalog/standards/sist/a492dddb-3176-4d97-a886-0d44e27d7d6b/sist-iso-8133-1998>

© ISO 1991

All rights reserved. No part of this publication may be reproduced or utilized in any form or by any means, electronic or mechanical, including photocopying and microfilm, without permission in writing from the publisher.

International Organization for Standardization
Case Postale 56 • CH-1211 Genève 20 • Switzerland

Printed in Switzerland

Introduction

In hydraulic fluid power systems, power is transmitted and controlled through a liquid under pressure within an enclosed circuit.

One component of such systems is the fluid power cylinder. This is a device which converts power into linear mechanical force and motion. It consists of a movable element, i.e. a piston and piston rod, operating within a cylindrical bore.

iTeh STANDARD PREVIEW (standards.iteh.ai)

[SIST ISO 8133:1998](#)

<https://standards.iteh.ai/catalog/standards/sist/a492dddb-3176-4d97-a886-0d44e27d7d6b/sist-iso-8133-1998>

iTeh STANDARD PREVIEW
(standards.iteh.ai)

This page intentionally left blank

SIST ISO 8133:1998

<https://standards.iteh.ai/catalog/standards/sist/a492dddb-3176-4d97-a886-0d44e27d7d6b/sist-iso-8133-1998>

Hydraulic fluid power — Single rod cylinders, 16 MPa (160 bar) compact series — Accessory mounting dimensions

1 Scope

This International Standard specifies the mounting dimensions required for interchangeability of accessories for 16 MPa (160 bar¹⁾) compact cylinders conforming to ISO 6020-2. The accessories have been designed specifically for use with cylinders manufactured in accordance with ISO 6020-2, but this does not limit their application.

This International Standard covers the following accessories:

- rod eye for spherical bearing (see figure 1 and table 1);
- clevis bracket for spherical bearing (see figure 2 and table 2);
- pivot pin for spherical bearing (cotter pin or snap ring type) (see figure 3 and table 3);
- pivot pin for spherical bearing, with locking plate (see figure 4 and table 4);
- locking plate for spherical bearing (see figure 5 and table 5);
- plain rod clevis (see figure 6 and table 6);
- plain rod eye (see figure 7 and table 7);
- plain eye bracket (see figure 8 and table 8);
- plain clevis bracket (see figure 9 and table 9);
- plain pivot pin (cotter pin or snap ring type) (see figure 10 and table 10).

These accessories are used on hydraulic cylinders for mechanically transmitting the cylinder force. The

design of these accessories is based on the maximum forces resulting from the specified internal diameters of the cylinders and pressures according to ISO 3320 and ISO 3322.

2 Normative references

The following standards contain provisions which, through reference in this text, constitute provisions of this International Standard. At the time of publication, the editions indicated were valid. All standards are subject to revision, and parties to agreements based on this International Standard are encouraged to investigate the possibility of applying the most recent editions of the standards indicated below. Members of IEC and ISO maintain registers of currently valid International Standards.

ISO 286-2:1988, *ISO system of limits and fits — Part 2: Tables of standard tolerance grades and limit deviations for holes and shafts.*

ISO 3320:1987, *Fluid power systems and components — Cylinder bores and piston rod diameters — Metric series.*

ISO 3322:1985, *Fluid power systems and components — Cylinders — Nominal pressures.*

ISO 5598:1985, *Fluid power systems and components — Vocabulary.*

ISO 6020-2:1981, *Hydraulic fluid power — Single rod cylinders — Mounting dimensions — 160 bar (16 000 kPa) series — Part 2: Compact series.*

3 Definitions

For the purposes of this International Standard, the definitions given in ISO 5598 apply.

1) 1 bar = 0,1 MPa = 10⁵ Pa; 1 MPa = 1 N/mm²

4 Mounting dimensions

The mounting dimensions for accessories are shown in figures 1 to 10 and given in tables 1 to 10.

5 General

5.1 Material

5.1.1 The accessories shall be made of material having a minimum proof stress of non-proportional elongation, $R_{p0,2}$, of 250 N/mm² and a percentage elongation after fracture, A min., of at least 12 %.

5.1.2 The radial spherical plain bearings mounted in the rod ends shall be made of steel with a minimum surface hardness of 50 HRC.

5.2 Load capacity

All cross-sections shall be selected so that, under the maximum tensile load produced by the cylinder, the yield strength of the material used for the accessories is at least 2,5 times the maximum tensile load.

6 Application instructions

6.1 Installation

6.1.1 A tolerance of f8 is recommended for plain bearing shafts (see ISO 286-2).

Usually a tolerance of h6 shall be used for the shaft fitting the spherical plain bearing bore. However, in exceptional cases (for example where there are difficulties in cylinder installation), a tolerance of f7 may be admitted. In this instance, a case-hardened shaft is recommended since movement will occur between the shaft and the bearing bore, and lubrication should be carried out through the shaft.

6.1.2 The specified tilting angle of $\pm 3^\circ$ for the spherical bearing can still be obtained even after the clevis is in place next to the side faces of the spherical plain bearing's inner ring.

6.1.3 The rod clevis and the rod eye shall be screwed firmly against the piston rod shoulder before locking.

6.2 Life of spherical plain bearing

6.2.1 The life of the spherical plain bearing is influenced by many factors, such as the specific load, angle of oscillation, type of lubricant and frequency of lubrication.

6.2.2 The spherical plain bearings are designed to give an acceptable bearing life under normal operating conditions.

6.2.3 Where a constant unidirectional load is applied or other unusual operating conditions exist, consultation with the supplier is recommended.

6.3 Lubrication

6.3.1 Sufficient lubrication for the satisfactory performance of these accessories shall be provided.

6.3.2 The method and frequency of such lubrication depends on the particular operating conditions.

7 Example of ordering designation

A plain rod eye with a bore $CK = 28$ mm and of type 30 shall be designated as follows:

Plain rod eye ISO 8133 - 30

8 Identification statement (Reference to this International Standard)

Use the following statement in test reports, catalogues and sales literature when electing to comply with this International Standard:

"Interchangeable cylinder mounting dimensions selected in accordance with ISO 8133, *Hydraulic fluid power — Single rod cylinders, 16 MPa (160 bar) compact series — Accessory mounting dimensions.*"

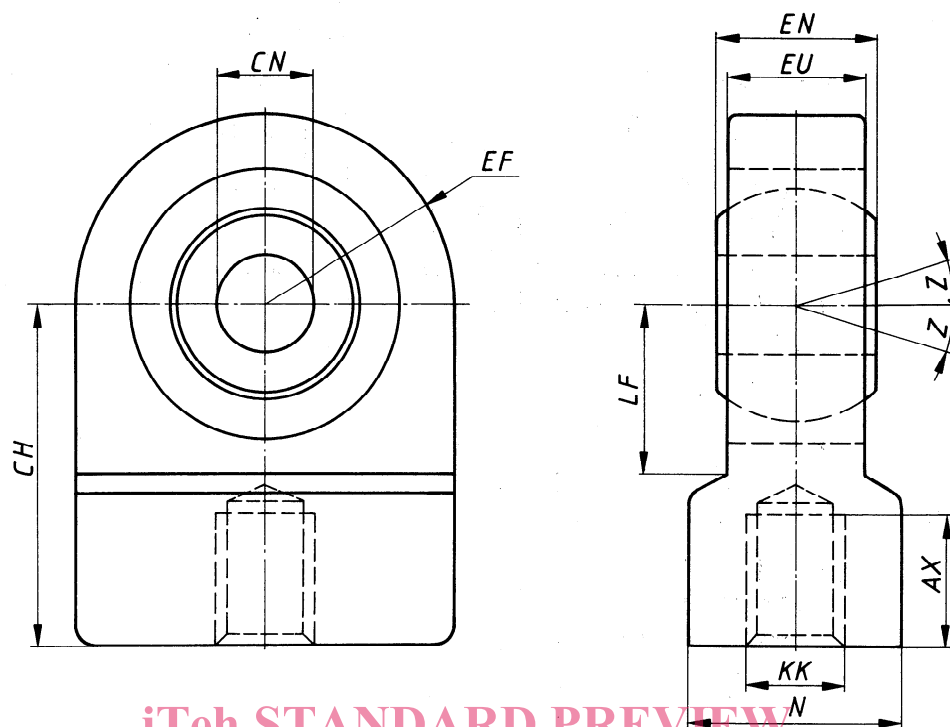

iTeh STANDARD PREVIEW
(standards.iteh.ai)

NOTE — A suitable locking device shall be used.

Figure 1 — Rod eye with spherical bearing

SIST ISO 8133:1998

<https://standards.iteh.ai/catalog/standards/sist/a492dddb-3176-4d97-a886-0d44e27d7d6b/sist-iso-8133-1998>

Table 1 — Dimensions of rod eye with spherical bearing

Dimensions in millimetres

Type	Nominal force N	N max.	KK	CN		EN		EF max.	CH js13	AX min.	LF min.	EU h13	Tilting angle Z min.
				tol. μm	tol. μm	tol. μm	tol. μm						
12	8 000	17	M10 × 1,25	12	0	10		20	42	15	16	8	3°
16	12 500	21	M12 × 1,25	16	-8	14		22,5	48	17	20	11	
20	20 000	25	M14 × 1,5	20		16		27,5	58	19	25	13	
25	32 000	30	M16 × 1,5	25		20	0	32,5	68	23	30	17	
30	50 000	36	M20 × 1,5	30	0	22	-120	40	85	29	35	19	
40	80 000	45	M27 × 2	40	-12	28		50	105	37	45	23	
50	125 000	55	M33 × 2	50		35		62,5	130	46	58	30	
60	200 000	68	M42 × 2	60	0	44	0	80	150	57	68	38	
80	320 000	90	M48 × 2	80	-15	55	-150	102,5	185	64	92	47	
100	500 000	110	M64 × 3	100	0	70	-200	120	240	86	116	57	