

INTERNATIONAL STANDARD

**ISO
8140**

Second edition
1991-12-01

Pneumatic fluid power — Cylinders, 1 000 kPa (10 bar) series — Rod end clevis — Mounting dimensions

iTeh STANDARD PREVIEW

(standards.iteh.ai) *Transmissions pneumatiques — Vérins 1 000 kPa (10 bar) — Chapes
d'extrémité de tige de piston — Dimensions d'interchangeabilité*

ISO 8140:1991

<https://standards.iteh.ai/catalog/standards/sist/29ba4bd1-6efd-4cbe-9e5-c0fe645acb88/iso-8140-1991>



Reference number
ISO 8140:1991(E)

Foreword

ISO (the International Organization for Standardization) is a worldwide federation of national standards bodies (ISO member bodies). The work of preparing International Standards is normally carried out through ISO technical committees. Each member body interested in a subject for which a technical committee has been established has the right to be represented on that committee. International organizations, governmental and non-governmental, in liaison with ISO, also take part in the work. ISO collaborates closely with the International Electrotechnical Commission (IEC) on all matters of electrotechnical standardization.

Draft International Standards adopted by the technical committees are circulated to the member bodies for voting. Publication as an International Standard requires approval by at least 75 % of the member bodies casting a vote.

International Standard ISO 8140 was prepared by Technical Committee ISO/TC 131, *Fluid power systems*, Sub-Committee SC 3, *Cylinders*.

This second edition cancels and replaces the first edition (ISO 8140:1986), figure 1 and table 1 of which have been technically revised.

Annex A of this International Standard is for information only.

Introduction

In pneumatic fluid power, power is transmitted and controlled through a gas under pressure within a circuit.

One component of such systems is the pneumatic fluid power cylinder. This is a device which converts power into linear mechanical force and motion. It consists of a movable element, i.e. a piston and piston rod, operating within a cylindrical bore.

iTeh STANDARD PREVIEW (standards.iteh.ai)

[ISO 8140:1991](#)

<https://standards.iteh.ai/catalog/standards/sist/29ba4bd1-6efd-4cbe-9e5-c0fe645acb88/iso-8140-1991>

iTeh STANDARD PREVIEW
(standards.iteh.ai)

This page intentionally left blank
ISO 8140:1991

<https://standards.iteh.ai/catalog/standards/sist/29ba4bd1-6efd-4cbe-9ef5-c0fe645acb88/iso-8140-1991>

Pneumatic fluid power — Cylinders, 1 000 kPa (10 bar) series — Rod end clevis — Mounting dimensions

1 Scope

This International Standard specifies the mounting dimensions required for interchangeability of rod end clevis of pneumatic cylinders. The rod end clevis have been designed specifically for use with 1 000 kPa [10 bar¹⁾] series cylinders manufactured in accordance with ISO 6430, ISO 6431 and ISO 6432 but this does not limit their application.

The clevis are used on piston rods of pneumatic cylinders for mechanically transmitting the cylinder force. The design of the clevis is based on the maximum forces resulting from the specified internal diameter of the cylinders and pressure according to ISO 6430, ISO 6431 and ISO 6432.

2 Normative references

The following standards contain provisions which, through reference in this text, constitute provisions of this International Standard. At the time of publication, the editions indicated were valid. All standards are subject to revision, and parties to agreements based on this International Standard are encouraged to investigate the possibility of applying the most recent editions of the standards indicated below. Members of IEC and ISO maintain registers of currently valid International Standards.

ISO 286-2:1988, *ISO system of limits and fits — Part 2: Tables of standard tolerance grades and limit deviations for holes and shafts.*

ISO 5598:1985, *Fluid power systems and components — Vocabulary.*

ISO 6430:—²⁾, *Pneumatic fluid power — Single rod cylinders with integral mountings — 1 000 kPa (10 bar) series — Bores from 32 mm to 250 mm — Mounting dimensions.*

ISO 6431:—³⁾, *Pneumatic fluid power — Single rod cylinders with detachable mountings — 1 000 kPa (10 bar) series — Bores from 32 mm to 320 mm — Mounting dimensions.*

ISO 6432:1985, *Pneumatic fluid power — Single rod cylinders — 10 bar (1 000 kPa) series — Bores from 8 to 25 mm — Mounting dimensions.*

3 Definitions

For the purposes of this International Standard, the definitions given in ISO 5598 apply.

4 Mounting dimensions

See figure 1 and table 1.

1) 1 bar = 100 kPa = 10⁵ Pa; 1 Pa = 1 N/m².

2) To be published. (Revision of ISO 6430:1983)

3) To be published. (Revision of ISO 6431:1983)

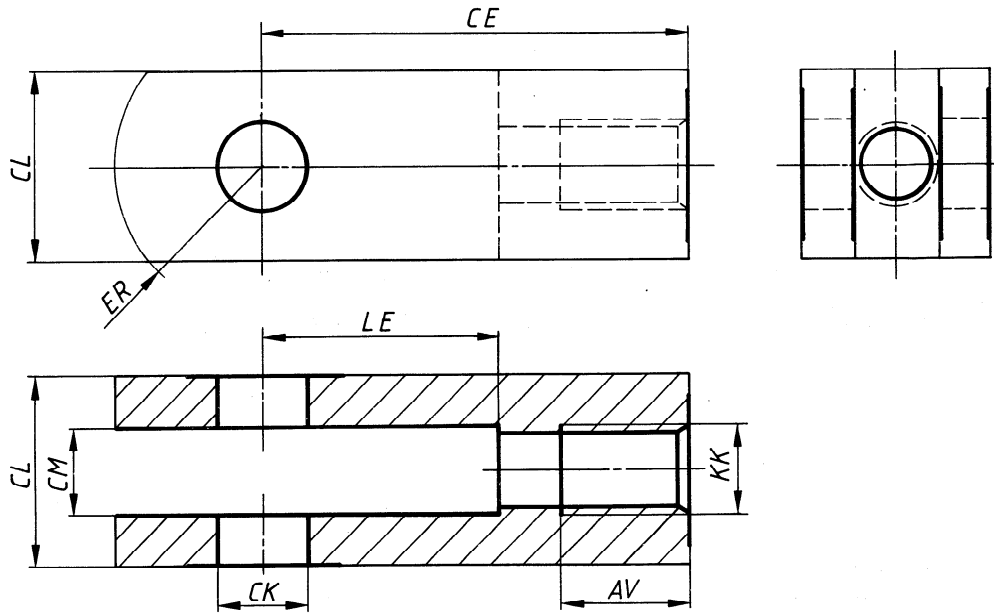

Figure 1 — Rod end clevis

Table 1 — Dimensions of rod end clevis
(standards.itech.ai)

Dimensions in millimetres

KK	AV min.	CK H9	CE	CL max.	CM	LE min.	ER max.
M4 × 0,7	8	4	16	8	4 ^{+0,4} _{+0,1}	8	6,5
M6 × 1	12	6	24	12	6 ^{+0,4} _{+0,1}	12	9,5
M8 × 1,25	16	8	32	16	8 ^{+0,50} _{+0,15}	16	13
M10 × 1,25	20	10	40	20	10 ^{+0,50} _{+0,15}	20	16
M12 × 1,25	22	12	48	24	12 ^{+0,50} _{+0,15}	24	19
M16 × 1,5	28	16	64	32	16 ^{+0,50} _{+0,15}	32	25
M20 × 1,5	33	20	80	40	20 ^{+0,60} _{+0,15}	40	32
M24 × 2 ¹⁾	42	25	100	50	25 ^{+0,60} _{+0,15}	50	41
M27 × 2	51	30	110	55	30 ^{+0,60} _{+0,15}	54	45
M36 × 2	56	35	144	70	35 ^{+0,60} _{+0,15}	72	57
M42 × 2	60	40	168	85	40 ^{+0,60} _{+0,15}	84	77
M48 × 2	65	50	192	96	50 ^{+0,60} _{+0,15}	96	88

1) This thread will be progressively abandoned and shall not be considered for new designs.

5 Application instructions

5.1 Installation

5.1.1 The tolerance of f8 is recommended for the bearing shaft (see ISO 286-2).

5.1.2 The rod end clevis shall be locked with a locking nut.

5.2 Lubrication

5.2.1 Sufficient lubrication shall be provided for the satisfactory performance of the rod end clevis.

5.2.2 The method and frequency of such lubrication depends on the particular operating conditions.

6 Example of ordering designation

A rod end clevis with male thread of $KK = M12 \times 1,25$ shall be designed as follows:

Rod end ISO 8140 - M12 × 1,25

7 Identification statement (Reference to this International Standard)

Use the following statement in test reports, catalogues and sales literature when electing to comply with this International Standard:

“Cylinder rod end clevis mounting dimensions selected in accordance with ISO 8140, *Pneumatic fluid power — Cylinders, 1000 kPa (10 bar) series — Rod end clevis — Mounting dimensions.*”

iTeh STANDARD PREVIEW (standards.iteh.ai)

ISO 8140:1991

<https://standards.iteh.ai/catalog/standards/sist/29ba4bd1-6efd-4cbe-9e5-c0fe645acb88/iso-8140-1991>

Annex A
(informative)

Bibliography

- [1] ISO 6099:1985, *Fluid power systems and components — Cylinders — Identification code for mounting dimensions and mounting types.*

iTeh STANDARD PREVIEW
(standards.iteh.ai)

ISO 8140:1991

<https://standards.iteh.ai/catalog/standards/sist/29ba4bd1-6efd-4cbe-9ef5-c0fe645acb88/iso-8140-1991>

iTeh STANDARD PREVIEW
(standards.iteh.ai)

ISO 8140:1991

<https://standards.iteh.ai/catalog/standards/sist/29ba4bd1-6efd-4cbe-9e5-c0fe645acb88/iso-8140-1991>

UDC 621.5-222:621.8.031

Descriptors: pneumatic fluid power, pneumatic equipment, pneumatic cylinders, piston-rods, dimensions, mounting dimensions, designation, interchangeability.

Price based on 4 pages
