

INTERNATIONAL
STANDARD

ISO
8144-1

First edition
1995-10-15

**Thermal insulation — Mineral wool mats
for ventilated roof spaces —**

Part 1:

Specification for applications with restricted
ventilation

<https://standards.iteh.ai/catalog/standards/sist/84582fbc9e-41f9-a0a9-667161372c10/iso-8144-1-1995>
ISO 8144-1:1995
Isolation thermique — Feutres en laine minérale pour sous-toitures
ventilées

Partie 1: Spécifications pour application dans des conditions de ventilation
restreinte

INTERNATIONAL

ISO



Reference number
ISO 8144-1:1995(E)

Foreword

ISO (the International Organization for Standardization) is a worldwide federation of national standards bodies (ISO member bodies). The work of preparing International Standards is normally carried out through ISO technical committees. Each member body interested in a subject for which a technical committee has been established has the right to be represented on that committee. International organizations, governmental and non-governmental, in liaison with ISO, also take part in the work. ISO collaborates closely with the International Electrotechnical Commission (IEC) on all matters of electrotechnical standardization.

Draft International Standards adopted by the technical committees are circulated to the member bodies for voting. Publication as an International Standard requires approval by at least 75 % of the member bodies casting a vote.

International Standard ISO 8144-1 was prepared by Technical Committee ISO/TC 163, *Thermal insulation*, Subcommittee SC 3, *Insulation products for building applications*.

ISO 8144 consists of the following parts, under the general title *Thermal insulation — Mineral wool mats for ventilated roof spaces*:

- Part 1: *Specification for applications with restricted ventilation*
- Part 2: *Specification for horizontal applications with unrestricted ventilation*

Annexes A, B and C form an integral part of this part of ISO 8144. Annexes D, E and F are for information only.

© ISO 1995

All rights reserved. Unless otherwise specified, no part of this publication may be reproduced or utilized in any form or by any means, electronic or mechanical, including photocopying and microfilm, without permission in writing from the publisher.

International Organization for Standardization
Case Postale 56 • CH-1211 Genève 20 • Switzerland

Printed in Switzerland

Thermal insulation — Mineral wool mats for ventilated roof spaces —

Part 1: Specification for applications with restricted ventilation

1 Scope

This part of ISO 8144 specifies the properties and acceptable tolerances for bonded man-made mineral wool thermal insulating mats (batts and rolls). The mats specified in this part of ISO 8144 are for use within ventilated roof spaces of buildings where the essential ventilation of the roof space may be restricted if the thickness recovery of the insulation is excessive. [See annex E and ISO/TR 9774:1990 (figure 1, sketches 1 and 5) for typical locations.] They may be supplied flat, folded or in the form of a roll.

The properties to be declared by the manufacturer at the time of delivery are specified, as are some test methods for the determination of these properties. Essentially, mats do not change their properties and are dimensionally stable for the temperature and humidity conditions within a ventilated roof.

This part of ISO 8144 provides limiting values for most of the properties. These limiting values are for specification purposes only; design values may be derived from these by taking into account the environmental factors affecting the thermal performance of the product, the influence of the product properties on installation, and the effect of workmanship on the thermal performance. For converting declared R - or λ -values to design values, see, for example, ISO 10456.

Mats may be supplied with a factory-applied facing, but facings are not covered by this part of ISO 8144.

In general, mats are not designed to support any applied load. For this reason, only the mechanical properties required for adequate handling during application are specified.

The sampling and conformity control procedures described in annex D, and the certification procedure described in annex F, are recommendations only.

2 Normative references

The following standards contain provisions which, through reference in this text, constitute provisions of this part of ISO 8144. At the time of publication, the editions indicated were valid. All standards are subject to revision, and parties to agreements based on this part of ISO 8144 are encouraged to investigate the possibility of applying the most recent editions of the standards indicated below. Members of IEC and ISO maintain registers of currently valid International Standards.

ISO 7345:1987, *Thermal insulation — Physical quantities and definitions*.

ISO 8301:1991, *Thermal insulation — Determination of steady-state thermal resistance and related properties — Heat flow meter apparatus*.

ISO 8302:1991, *Thermal insulation — Determination of steady-state thermal resistance and related properties — Guarded hot plate apparatus.*

ISO/TR 9774:1990, *Thermal-insulation materials — Application categories and basic requirements — Guidelines for the harmonization of International Standards and other specifications.*

ISO 10456:—¹⁾, *Thermal insulation — Building materials and products — Determination of declared and design thermal values.*

3 Definitions

For the purposes of this part of ISO 8144, the following definitions apply.

3.1 mineral wool: Vitreous fibres having a woolly consistency made from rock, slag or glass.

3.2 mat: Flexible fibrous insulation supplied in the form of rolls or batts, which may be faced but not enclosed.

3.3 batt: Portion of a mat in the form of a rectangular piece, generally between 1 m and 3 m in length and usually supplied flat or folded.

3.4 roll: Mat supplied in the form of spirally wound cylindrical packages.

4 Sampling and conformity control

For the purposes of sampling and conformity control by inspection lots, the procedures described in annex D are recommended.

In plants where different product types are manufactured on the same production line within short intervals as regards time and quantity, it is recommended that production be subjected to a third-party certification system as described in annex F.

NOTE 1 Annexes D and F, which are not normative parts of this part of ISO 8144, provide some possible procedures for attestation of conformity which have to be agreed between the manufacturer and the consumer. A general International Standard on the procedure of attestation of conformity for all thermal insulation products is being prepared and will replace the common clauses of annexes.

1) To be published.

5 Required properties

5.1 Dimensions

The manufacturer shall declare the nominal length, width and thickness of the mats.

These dimensions shall be measured in accordance with annex A and shall be subject to the tolerances detailed in table 1. Tighter tolerances may be necessary for certain applications; these shall be agreed to by the supplier and purchaser.

5.2 Fire behaviour

These insulation materials, including any facings, shall meet the fire regulations and codes that apply in the locality in which they are applied.

Table 1 — Dimensional tolerances

Dimension	Permissible deviations of measured values from nominal dimensions	Test method
Length, <i>l</i>	− 2 %, + excess permitted on average of measured values for each single specimen	Clause A.1
Width, <i>b</i>	± 2 % or + 10 mm, whichever is less, on average of measured values for each single specimen	Clause A.1
Thickness, <i>d</i>	− 5 %, + 20 %, (the plus tolerance is limited to a maximum of + 15 mm) on average of all specimens tested For any single specimen, the measured thickness at each individual measuring point shall not deviate by more than 10 mm from the mean of measurement on that specimen	Clause A.2
Squareness of batts (rolls need not be tested)	For each 100 mm along the shortest face dimension, the maximum deviation shall not be more than 1 mm	Clause A.3

5.3 Thermal transmission properties

The thermal transmission properties of a product shall be declared by the manufacturer as either thermal resistance, *R*, or thermal conductivity, *λ* (see ISO 7345). The mean test temperature shall also be declared.

R and λ shall be determined in accordance with annex C (see also ISO 8301 or ISO 8302), and shall be subject to the tolerances given below.

Thermal transmission properties may be measured directly or they may be determined from measurements on other thicknesses of the material, provided that

- a) the material is of the same quality (density, fibre diameter and distribution, etc.) and is produced on the same production line;
- b) it can be demonstrated that λ does not vary by more than 2 % over the range of thicknesses where the calculation is applied.

The maximum thermal conductivity shall be equal to or less than the manufacturer's declared values.

The thermal resistance shall be equal to or greater than 95 % of the manufacturer's declared values.

NOTES

2 The apparent discrepancy between the requirements for thermal conductivity compared to thermal resistance arises from the negative tolerance on thickness permitted in table 1.

3 Because of the differences in manufacturing processes, two manufacturers may have the same thermal resistance but at slightly different thicknesses and/or densities.

5.4 Handling properties

The product shall have sufficient strength to be handled, transported and installed. When tested in accordance with the test method in annex B, the specimen shall support twice the mass of the mat or twice the mass of a specimen 10 m in length, whichever is less. It is normally not necessary to test faced products.

5.5 General properties

5.5.1 There are no test procedures specified for the following properties: however, for the requirements in 5.5.2 and 5.5.4, visual inspection and simple odour are respectively recommended.

For the properties of 5.5.3 and 5.5.5, the manufacturer shall be consulted and shall provide technical information.

5.5.2 The insulation shall be free of extraneous and coarse material and the fibre shall be distributed evenly.

5.5.3 The insulation shall not sustain the growth of fungus.

5.5.4 The insulation shall be free from objectionable odours.

5.5.5 The insulation shall not accelerate the corrosion of metallic surfaces with which it may come into contact in normal use.

6 Marking

Mineral wool insulation shall be delivered with the following information marked on the product or the package:

- a) manufacturer's name and product designation;
- b) manufacturing origin (location);
- c) type of facing (if any);
- d) production code;
- e) nominal length, width, thickness and area of insulation in the package;
- f) nominal R -value or nominal λ -value and mean temperature;
- g) additional markings as required by the national regulations of countries where the product is to be used, such as design values for R or λ , reaction to fire, and safety and health information;
- h) reference to this part of ISO 8144.

7 Test report

The test report shall be prepared by the laboratory that carried out the tests and shall include the following information:

- a) manufacturer's name and product designation;
- b) type of product and other description about facing and type;
- c) nominal dimensions;
- d) production code;
- e) information about sampling;
- f) manufacturer's declared R -value or λ -value and corresponding mean temperature;

- g) report of all test results, including maximum and minimum values, and deviation of individual thickness measurements from mean specimen thickness;
- h) comparison of test results and assessment with the manufacturer's claim and the requirements of this part of ISO 8144;
- i) statement of conformity with this part of ISO 8144;
- j) name and location of laboratory carrying out the tests.

iTeh STANDARD PREVIEW **(standards.iteh.ai)**

[ISO 8144-1:1995](https://standards.iteh.ai/catalog/standards/sist/8a84582f-bc9e-41f9-a0a9-667b61372c10/iso-8144-1-1995)

<https://standards.iteh.ai/catalog/standards/sist/8a84582f-bc9e-41f9-a0a9-667b61372c10/iso-8144-1-1995>

Annex A (normative)

Determination of dimensions of mats (batts or rolls)

A.1 Determination of length and width

A.1.1 Measuring device

A steel tape graduated in millimetres shall be used as a measurement device.

A.1.2 Specimens

All mats (batts or rolls) contained in one package, but not more than five batts selected by random sampling, shall be tested.

After opening the package, the mats shall be laid carefully on a flat surface (the rolls unrolled) and the dimensions measured.

A.1.3 Procedure

Place the steel tape (A.1.1) across the surface of the insulation material parallel to one edge and at right angles to the adjacent edge.

Take measurements at two positions on one face for length l , and three positions on one face for width b , as shown in figure A.1.

Measurements of length shall be read and rounded to the nearest 5 mm, and of width to the nearest 2 mm.

The length and width recorded shall be the mean of these measurements for each specimen.

Note the results in the test report.

A.1.4 Test report

The test report shall indicate the mean of the measurements of length and width for each specimen.

A.2 Determination of thickness

A.2.1 Principle

Measurement of the distance between a hard surface compatible with the specimen and on which the test specimen rests, and a pressure plate resting freely on the surface of that specimen.

A.2.2 Measuring device

The measuring device consists of a pressure plate and a pin.

The plate may be made from clear or transparent plastic or another suitable material. It shall be 200 mm square, fitted with a suitable thumb grip. The total mass of the plate and the grip shall be within the range 198 g to 210 g, so that it exerts a pressure on the specimen of $50 \text{ Pa} \pm 1,5 \text{ Pa}$ (see figure A.2).

The pin is made from steel rod 3 mm in diameter, and is sufficiently long to penetrate the full thickness of the specimen (see figure A.3), with 20 mm of one end sharpened to a point.

NOTE 4 Other measuring devices such as a dial gauge may be used, provided that the pressure plate exerts a load of $50 \text{ Pa} \pm 1,5 \text{ Pa}$ over an area 200 mm square.

A.2.3 Specimens

All mats (batts or rolls) contained in one package shall be tested.

Immediately after opening the package, batts shall be placed on a hard, flat, horizontal reference surface. If faced, the facing shall be placed downwards against this surface.

Rolls shall be completely unrolled and cut into pieces 1 m to 1,5 m long, discarding the first and last 0,5 m length of the roll. These pieces shall then be placed

on a horizontal hard reference surface with the facing, if any, downwards.

Before thickness measurements are taken, the products which have been compressed in the package, and which in the package have a thickness less than 90 % of the nominal thickness, shall be conditioned according to the following procedure:

- a) hold the piece vertically in both hands by the long edge, so that the other long edge is approximately 450 mm above the floor;
- b) drop the piece once so that it strikes the floor;
- c) repeat operations a) and b) on the opposite edge for all mats in the package or all the pieces cut from a roll;
- d) before taking any measurements, wait at least 5 min for the pieces to reach a state of equilibrium.

A.2.4 Procedure

At each point marked as shown in figure A.4, place the pressure plate on the specimen, lowering the plate slowly until it comes in contact with the surface, allowing it to rest freely under its own weight.

Force the pin with a rotating motion vertically downward through the specimen to the surface below.

Grasp the pin firmly at the thumb grip, and remove both the pin and the plate. Measure the distance from the point of the pin to the plate, to the nearest 1 mm. This distance is the thickness of the specimen at that point.

The thickness of the specimen shall be the average of the measurements made at all points on the specimen (see figure A.4).

Calculate the average of all the specimen thicknesses and report this as the average sample thickness.

Record the deviation of each thickness measurement from the mean of thickness measurements for each specimen.

Note the results in the test report.

A.2.5 Test report

The test report shall include the following information:

- a) the average thickness of each specimen;
- b) the average thickness of all the specimens as the average sample thickness;
- c) the deviation of each thickness measurement from the mean of the thickness measurements for each specimen.

A.3 Determination of squareness

A.3.1 Principle

Determination of the deviation from the squareness of the corners for a batt with a length less than 3 m.

A.3.2 Measuring devices

A carpenter's steel square with limbs at least 500 mm long and a steel tape graduated in millimetres shall be used as measuring devices.

A.3.3 Specimens

All batts contained in one package, but not more than five, randomly selected, shall be tested.

A.3.4 Procedure

Lay the specimen material on a flat surface and measure the deviation from squareness of the corners as follows.

Position the carpenter's steel square along one side of the parallel sides of the insulation, with the right angle of the square aligned against the adjoining edge as in figure A.5.

Measure the distance, a , at the point of greatest deviation between the edge of the specimen and the edge of the square. Record the distance in millimetres.

Calculate the deviation from squareness for the corners, expressed in millimetres per 100 mm, for each batt, and note the result in a test report.

A.3.5 Test report

The test report shall indicate the maximum deviation from squareness for batts, expressed in millimetres per 100 mm.

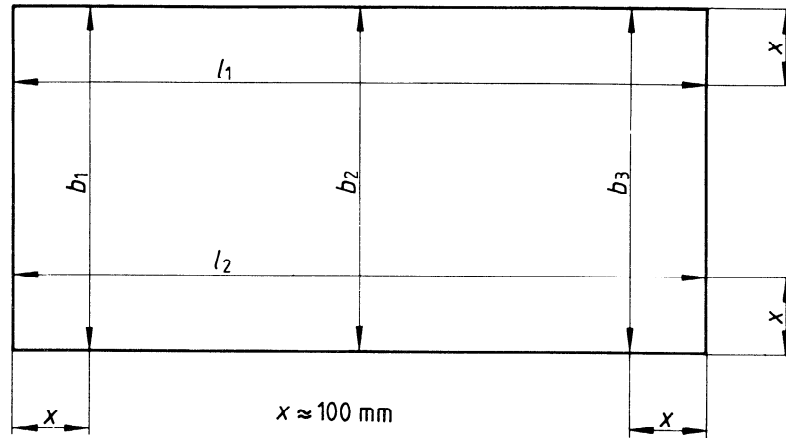

Figure A.1 — Location of measurements for length and width

iTeh STANDARD PREVIEW
 (standards.iteh.ai)

Dimensions in millimetres

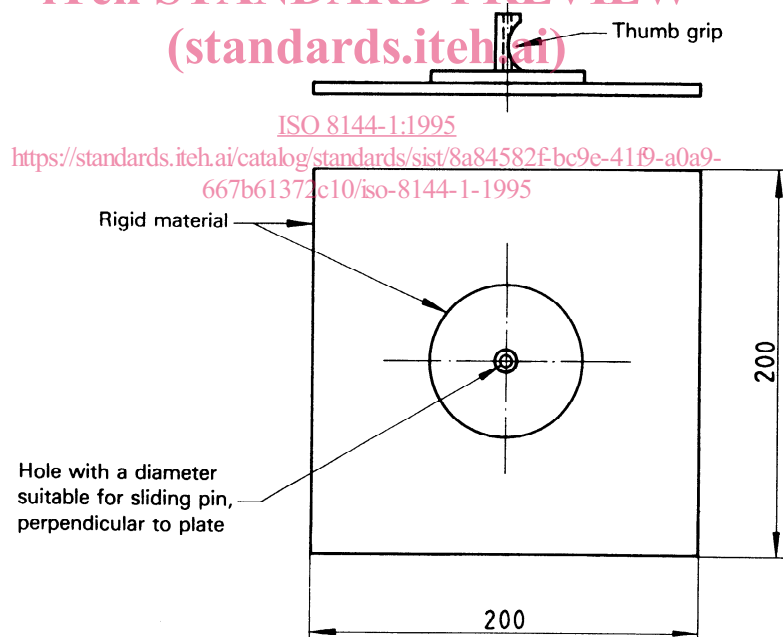

Figure A.2 — Pressure plate

Dimensions in millimetres

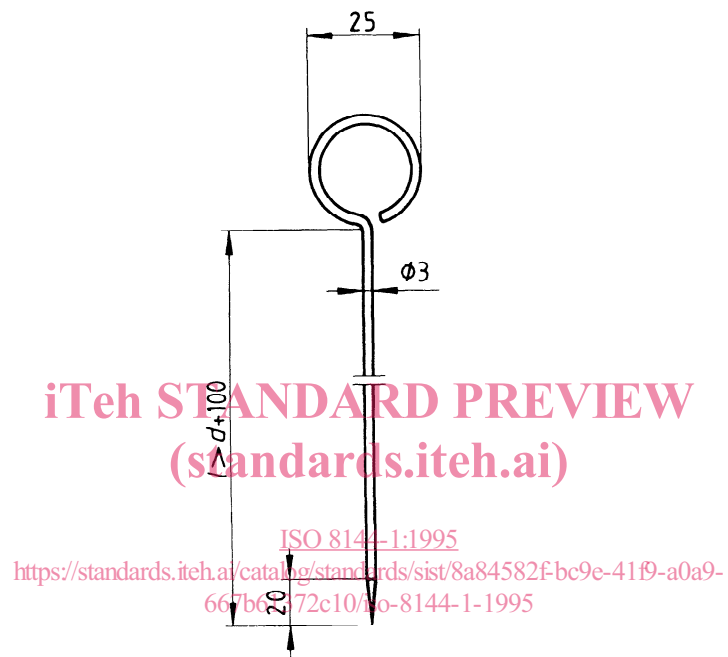

Figure A.3 — Pin

Dimensions in millimetres

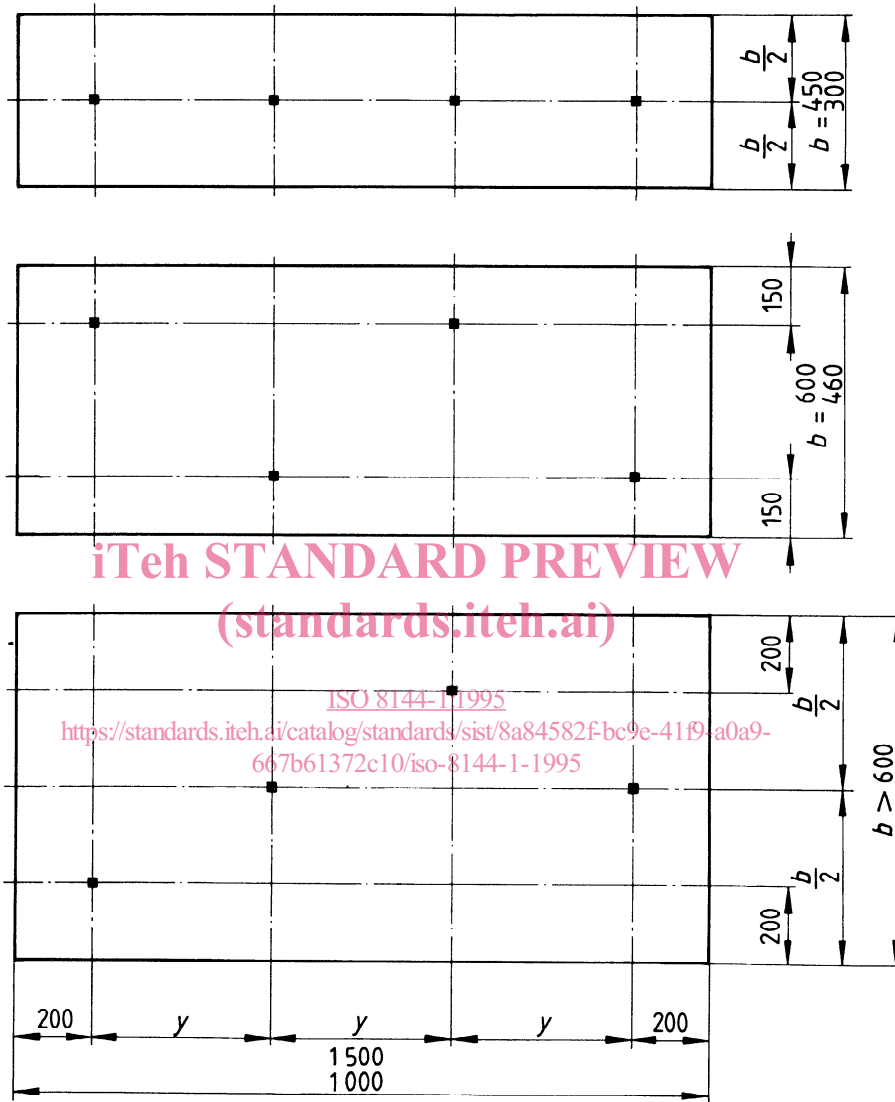

Figure A.4 — Locations for thickness measurements