

---

# International Standard



# 8220

---

INTERNATIONAL ORGANIZATION FOR STANDARDIZATION • МЕЖДУНАРОДНАЯ ОРГАНИЗАЦИЯ ПО СТАНДАРТИЗАЦИИ • ORGANISATION INTERNATIONALE DE NORMALISATION

---

## Aluminium oxide primarily used for the production of aluminium — Determination of the fine particle size distribution (less than 60 $\mu\text{m}$ ) — Method using electroformed sieves

iTeh STANDARD PREVIEW

*Oxyde d'aluminium principalement utilisé pour la production de l'aluminium — Détermination de la distribution granulométrique fine (inférieure à 60  $\mu\text{m}$ ) — Méthode par emploi de tamis électroformés*

First edition — 1986-09-15

ISO 8220:1986

<https://standards.iteh.ai/catalog/standards/sist/6907130f-d325-4c49-952e-dd00fd1b3a7/iso-8220-1986>

---

UDC 661.862.22 : 669.713 : 621.928

Ref. No. ISO 8220-1986 (E)

**Descriptors** : industrial products, aluminium oxide, tests, determination, particle size, test equipment, sieves, separation methods, aluminium, production.

Price based on 3 pages

## Foreword

ISO (the International Organization for Standardization) is a worldwide federation of national standards bodies (ISO member bodies). The work of preparing International Standards is normally carried out through ISO technical committees. Each member body interested in a subject for which a technical committee has been established has the right to be represented on that committee. International organizations, governmental and non-governmental, in liaison with ISO, also take part in the work.

Draft International Standards adopted by the technical committees are circulated to the member bodies for approval before their acceptance as International Standards by the ISO Council. They are approved in accordance with ISO procedures requiring at least 75 % approval by the member bodies voting.

International Standard ISO 8220 was prepared by Technical Committee ISO/TC 47, *Chemistry*.

Users should note that all International Standards undergo revision from time to time and that any reference made herein to any other International Standard implies its latest edition, unless otherwise stated.

# Aluminium oxide primarily used for the production of aluminium — Determination of the fine particle size distribution (less than 60 µm) — Method using electroformed sieves

## 1 Scope and field of application

This International Standard specifies a method for the determination of the particle size distribution (less than 60 µm) of aluminium oxide primarily used for the production of aluminium, using electroformed sieves.

NOTE — There is no correlation, for the calcined alumina, between the results obtained with the square-aperture and the round-aperture electroformed sieves.

The use of either kind of sieve should be clearly indicated in the compilation of the test report, as well as in the agreement protocols between suppliers and purchasers if the particle size distribution is indicated in the contract.

## 2 References

ISO 802, *Aluminium oxide primarily used for the production of aluminium — Preparation and storage of test samples.*

ISO 803, *Aluminium oxide primarily used for the production of aluminium — Determination of loss of mass at 300 °C (conventional moisture).*

ISO 3310/2, *Test sieves — Technical requirements and testing — Part 2 : Test sieves of metal perforated plate*

## 3 Principle

Quantitative separation by sieving of the particles in the range 63 to 16 µm suspended in an aqueous solution of a dispersing agent.

The sieves are square-aperture or round-aperture electroformed sieves, depending on their origin.

Drying and weighing of each sieved fraction.

## 4 Reagents and materials

During the analysis, use only reagents of recognized analytical grade and only distilled water or water of equivalent purity.

**4.1 Sodium hexametaphosphate** [(NaPO<sub>3</sub>)<sub>6</sub>], 1 g/l solution.

**4.2 Surface active agent**, non-ionic polyethoxyl, saturated solution.

## 5 Apparatus

Ordinary laboratory apparatus and

**5.1 Agitation device**, for the slow oscillation of the sieves (5.2) placed on a support, driven by a motor equipped with reduction gear and cam, capable of shaking the sieves with a frequency of 1 Hz and 10 mm amplitude.

A schematic drawing is shown in the figure.

**5.2 Set of electroformed sieves**, of maximal dimensions 75 mm (available diameter 65 mm), mounted on stainless steel frames and fitted with a cloth for supporting the electroformed membrane. The sizes of the apertures shall be 63 — 45 — 32 — 16 µm. The tolerances shall be those required by ISO 3310/2.

NOTE — Electroformed sieves of 80 and 100 µm are available. They may be used with test portions of about 2 g.

**5.3 Adjustable-height supports.**

**5.4 Crystallization vessels**, made of glass, diameter approximately 125 mm, height approximately 65 mm.

**5.5 Funnel**, made of polyethylene, diameter about 90 mm.

**5.6 Vacuum device.**

**5.7 Ultrasonic cleaner**, (maximum power : 100 W).

**5.8 Electric oven**, capable of being controlled at 110 ± 2 °C.

**5.9 Desiccator**, containing activated alumina or other suitable desiccant.

## 6 Procedure

### 6.1 Test portion

Depending on the sizes of the sieve apertures, weigh, to the nearest 0,000 1 g, the following masses of the sample, which have been taken in accordance with ISO 802 :

- 2 g for the 63 and 45 µm sieves;
- 1 g for the 32 µm sieve;
- 0,4 g for the 16 µm sieve.

NOTE — If the determination is carried out on a previously dried test portion, determine on a second test portion of mass equal to that taken for the determination, the "conventional moisture" at 300 °C, as specified in ISO 803. In this case, the final drying should be carried out at 300 °C.

It is necessary to use a second test portion in order to avoid any alteration of the primary granulometric composition (i.e., on the test portion as such).

### 6.2 Determination

Weigh the sieves to the nearest 0,000 1 g. Fit each sieve on one of the supporting arms of the agitation device (5.1), with the cam in the upper position. Place the crystallization vessels (5.4) on the adjustable-height supports (5.3) just below the sieves. Pour into the crystallization vessel an amount of the sodium metaphosphate solution (4.1) sufficient to touch the lower rim of each sieve. Add 4 or 5 drops of the surface active agent (4.2). Transfer the test portions into the sieves and start the agitation device.

If the alumina agglomerates, break up the lumps using a fine jet of water. Collect the alumina from time to time in the middle of the sieve using a jet of water.

After 15 min, stop the agitation, change the dispersing solution in the crystallization vessels and agitate again for 15 min. Repeat the change of dispersion solution and agitation until no further alumina passes through the sieve.

Fit the sieves onto the funnel (5.5), placed on the vacuum device (5.6), and remove the water. Wash both sieve and residue several times with water.

Dry the sieves with their contents in the electric oven (5.8), controlled at  $110 \pm 2$  °C, for at least 1 h. Weigh the sieve and residue to the nearest 0,000 1 g, after allowing to cool in the desiccator (5.9).

## 7 Expression of results

The particle size fraction passing through each sieve, expressed as a percentage by mass, is given by the formula

$$100 - \frac{m_2 - m_1}{m_0} \times 100$$

where

- $m_0$  is the mass, in grams, of the test portion;
- $m_1$  is the mass, in grams, of the empty sieve;
- $m_2$  is the mass, in grams, of the sieve with the residue.

NOTE — The precision parameters are under study and will be added later.

## 8 Cleaning of the sieves

Carefully remove the residual alumina from the sieve using a soft bristle brush. Immerse the sieve in the water contained in the tank of the ultrasonic cleaner (5.7). Start the cleaner and allow it to run for 2 min. Wash the sieve with water and dry it in the electric oven (5.8), controlled at  $110 \pm 2$  °C.

NOTE — It is important to examine the condition of the electroformed membrane microscopically. The membrane should be clean and completely free. Otherwise, it should be replaced.

## 9 Test report

The test report shall include the following particulars :

- a) an identification of the sample;
- b) the reference of the method used (square-aperture or round-aperture sieves);
- c) the results and the method of expression used;
- d) any unusual features noted during the determination;
- e) any operations not included in this International Standard or in the International Standard to which reference is made, or regarded as optional.

- 1 24 W motor — 60 rev/min
- 2 Double cam
- 3 Driving drum
- 4 Supporting rod
- 5 Sliding rod
- 6 Rod guide
- 7 Plane surface
- 8 Rod head
- 9 Supports
- 10 Ring for sieves

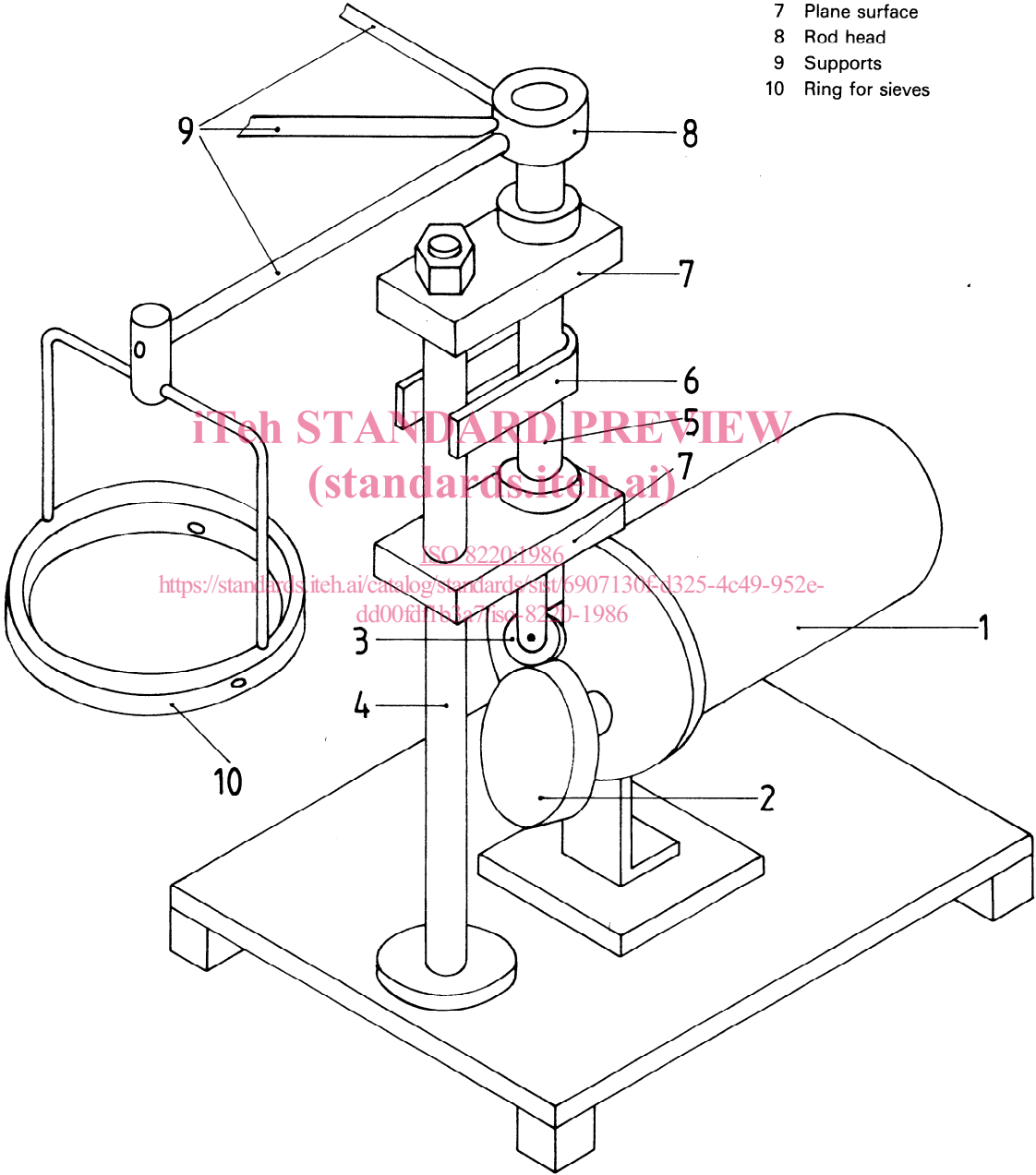

Figure — Typical agitation device for electroformed sieves

**iTeh STANDARD PREVIEW**  
**(standards.iteh.ai)**

This page intentionally left blank

ISO 8220:1986

<https://standards.iteh.ai/catalog/standards/sist/6907130f-d325-4c49-952e-dd00fd1b3a7/iso-8220-1986>

**iTeh STANDARD PREVIEW**  
**(standards.iteh.ai)**

This page intentionally left blank

[ISO 8220:1986](#)

<https://standards.iteh.ai/catalog/standards/sist/6907130f-d325-4c49-952e-dd00fd1b3a7/iso-8220-1986>

**iTeh STANDARD PREVIEW**  
**(standards.iteh.ai)**

This page intentionally left blank

ISO 8220:1986

<https://standards.iteh.ai/catalog/standards/sist/6907130f-d325-4c49-952e-dd00fd1b3a7/iso-8220-1986>