

INTERNATIONAL STANDARD

**High frequency inductive components – Electrical characteristics and measuring methods –
Part 2: Rated current of inductors for DC to DC converters**

<https://standards.iteh.ai/catalog/standards/sist/4b-06b4-4c34-9279-4ff8bbe49ad7/iec-62024-2-2008>

<https://standards.iteh.ai/catalog/standards/sist/4b-06b4-4c34-9279-4ff8bbe49ad7/iec-62024-2-2008>

Withstand



THIS PUBLICATION IS COPYRIGHT PROTECTED

Copyright © 2008 IEC, Geneva, Switzerland

All rights reserved. Unless otherwise specified, no part of this publication may be reproduced or utilized in any form or by any means, electronic or mechanical, including photocopying and microfilm, without permission in writing from either IEC or IEC's member National Committee in the country of the requester.

If you have any questions about IEC copyright or have an enquiry about obtaining additional rights to this publication, please contact the address below or your local IEC member National Committee for further information.

IEC Central Office
3, rue de Varembe
CH-1211 Geneva 20
Switzerland
Email: inmail@iec.ch
Web: www.iec.ch

About the IEC

The International Electrotechnical Commission (IEC) is the leading global organization that prepares and publishes International Standards for all electrical, electronic and related technologies.

About IEC publications

The technical content of IEC publications is kept under constant review by the IEC. Please make sure that you have the latest edition, a corrigenda or an amendment might have been published.

- Catalogue of IEC publications: www.iec.ch/searchpub

The IEC on-line Catalogue enables you to search by a variety of criteria (reference number, text, technical committee,...). It also gives information on projects, withdrawn and replaced publications.

- IEC Just Published: www.iec.ch/online_news/justpub

Stay up to date on all new IEC publications. Just Published details twice a month all new publications released. Available on-line and also by email.

- Electropedia: www.electropedia.org

The world's leading online dictionary of electronic and electrical terms containing more than 20 000 terms and definitions in English and French, with equivalent terms in additional languages. Also known as the International Electrotechnical Vocabulary online.

- Customer Service Centre: www.iec.ch/webstore/custserv

If you wish to give us your feedback on this publication or need further assistance, please visit the Customer Service Centre FAQ or contact us:

Email: csc@iec.ch
Tel.: +41 22 919 02 11
Fax: +41 22 919 03 00

INTERNATIONAL STANDARD

**High frequency inductive components – Electrical characteristics and measuring methods –
Part 2: Rated current of inductors for DC to DC converters**

<https://standards.iteh.ai/catalog/standards/sist/4b-06b4-4c34-9279-4ff8bbe49ad7/iec-62024-2-2008>

INTERNATIONAL
ELECTROTECHNICAL
COMMISSION

PRICE CODE



ICS 29.100.10

ISBN 978-2-88910-607-3

CONTENTS

FOREWORD.....	3
1 Scope.....	5
2 Normative references	5
3 Terms and definitions	5
4 Standard atmospheric conditions.....	6
4.1 Standard atmospheric conditions for testing	6
4.2 Reference conditions.....	6
5 Measuring method of DC saturation limited current.....	6
5.1 General.....	6
5.2 Test conditions.....	6
5.3 Measurement circuit and calculation.....	7
5.4 Attachment jig of inductor.....	8
5.5 Measuring method.....	8
5.6 Quality conformance inspection.....	8
6 Measuring method of temperature rise limited current	8
6.1 General.....	8
6.2 Test conditions.....	9
6.3 Measurement jig.....	9
6.3.1 Printed-wiring board method.....	9
6.3.2 Lead wire method.....	11
6.4 Measuring method and calculation.....	12
6.4.1 Resistance-substitution method.....	12
6.4.2 Thermo-couple method.....	13
6.5 Quality conformance inspection.....	14
7 Determination of rated current.....	14
8 Information to be given in the detail specification.....	14
8.1 Measuring method of DC saturation limited current	14
8.2 Measuring method of temperature rise limited current	15
Annex A (informative) Example of recommended description on product specification sheets and catalogues	16
Figure 1 – Inductance measurement circuit under application of DC saturation condition.....	7
Figure 2a) – Example of printed-wiring board for SMD type	10
Figure 2b) – Example of printed-wiring board for leaded type.....	11
Figure 2 – Example of printed-wiring board.....	11
Figure 3 – Temperature rise measurement circuit by resistance substitution method.....	12
Figure 4 – Temperature rise measurement circuit by thermo-couple method	13
Table 1 – Width of circuits	9
Table 2 – Wire size of circuits	12

INTERNATIONAL ELECTROTECHNICAL COMMISSION

HIGH FREQUENCY INDUCTIVE COMPONENTS – ELECTRICAL CHARACTERISTICS AND MEASURING METHODS –

Part 2: Rated current of inductors for DC to DC converters

FOREWORD

- 1) The International Electrotechnical Commission (IEC) is a worldwide organization for standardization comprising all national electrotechnical committees (IEC National Committees). The object of the IEC is to promote international co-operation on all questions concerning standardization in the electrical and electronic fields. To this end and in addition to other activities, IEC publishes International Standards, Technical Specifications, Technical Reports, Publicly Available Specifications (PAS) and Guides (hereafter referred to as "IEC Publication(s)"). Their preparation is entrusted to technical committees; any IEC National Committee interested in the subject dealt with may participate in this preparatory work. International, governmental and non-governmental organizations liaising with the IEC also participate in this preparation. IEC collaborates closely with the International Organization for Standardization (ISO) in accordance with conditions determined by agreement between the two organizations.
- 2) The formal decisions or agreements of IEC on technical matters express, as nearly as possible, an international consensus of opinion on the relevant subjects since each technical committee has representation from all interested IEC National Committees.
- 3) IEC Publications have the form of recommendations for international use and are accepted by IEC National Committees in that sense. While all reasonable efforts are made to ensure that the technical content of IEC Publications is accurate, IEC cannot be held responsible for the way in which they are used or for any misinterpretation by any end user.
- 4) In order to promote international uniformity, IEC National Committees undertake to apply IEC Publications transparently to the maximum extent possible in their national and regional publications. Any divergence between any IEC Publication and the corresponding national or regional publication shall be clearly indicated in the latter.
- 5) IEC provides no marking procedure to indicate its approval and cannot be rendered responsible for any equipment declared to be in conformity with an IEC Publication.
- 6) All users should ensure that they have the latest edition of this publication.
- 7) No liability shall attach to IEC or its directors, employees, servants or agents including individual experts and members of its technical committees and IEC National Committees for any personal injury, property damage or other damage of any nature whatsoever, whether direct or indirect, or for costs (including legal fees) and expenses arising out of the publication, use of, or reliance upon, this IEC Publication or any other IEC Publications.
- 8) Attention is drawn to the Normative references cited in this publication. Use of the referenced publications is indispensable for the correct application of this publication.
- 9) Attention is drawn to the possibility that some of the elements of this IEC Publication may be the subject of patent rights. IEC shall not be held responsible for identifying any or all such patent rights.

International Standard IEC 62024-2 has been prepared IEC technical committee 51: Magnetic components and ferrite materials.

The text of this standard is based on the following documents:

FDIS	Report on voting
51/937/FDIS	51/941/RVD

Full information on the voting for the approval of this standard can be found in the report on voting indicated in the above table.

This publication has been drafted in accordance with the ISO/IEC Directives, Part 2.

A list of all parts of IEC 62024 series, under the general title *High frequency inductive components – Electrical characteristics and measuring methods*, can be found on the IEC website.

The committee has decided that the contents of this publication will remain unchanged until the maintenance result date indicated on the IEC web site under "<http://webstore.iec.ch>" in the data related to the specific publication. At this date, the publication will be

- reconfirmed,
- withdrawn,
- replaced by a revised edition, or
- amended.

A bilingual version of this publication may be issued at a later date.



HIGH FREQUENCY INDUCTIVE COMPONENTS – ELECTRICAL CHARACTERISTICS AND MEASURING METHODS –

Part 2: Rated current of inductors for DC to DC converters

1 Scope

This part of IEC 62024 specifies the measuring methods of the rated direct current limits for small inductors.

Standardized measuring methods for the determination of ratings enable users to accurately compare the current ratings given in various manufacturers' data books.

This standard is applicable to leaded and surface mount inductors with dimensions according to IEC 62025-1 and generally with rated current less than 22 A, although inductors with rated current greater than 22 A are available that fall within the dimension restrictions of this standard (no larger than 12 mm × 12 mm footprint approximately). These inductors are typically used in DC to DC converters built on PCB, for electric and telecommunication equipment, and small size switching power supply units.

The measuring methods are defined by the saturation and temperature rise limitations induced solely by direct current.

2 Normative references

The following referenced documents are indispensable for the application of this document. For dated references, only the edition cited applies. For undated references, the latest edition of the referenced document (including any amendments) applies.

IEC 60068-1, *Environmental testing – Part 1: General and guidance*

IEC 62025-1, *High frequency inductive components – Non-electrical characteristics and measuring methods – Part 1: Fixed, surface mounted inductors for use in electronic and telecommunication equipment*

3 Terms and definitions

For the purposes of this document, the following terms and definitions apply.

3.1

DC saturation limited current

allowable value of DC current for which the decrease of the inductance is within the specified value

3.2

temperature rise limited current

allowable value of DC current for which the self-generation heat of the inductor results in temperature rise within the specified value

4 Standard atmospheric conditions

4.1 Standard atmospheric conditions for testing

Standard atmospheric conditions for testing shall be as follows (see 5.3.1 of IEC 60068-1):

- temperature: 15 °C to 35 °C;
- relative humidity: 25 % to 75 %;
- air pressure: 86 kPa to 106 kPa.

In the event of dispute or where required, the measurements shall be repeated using the referee temperatures and such other conditions as given in 4.2.

4.2 Reference conditions

For reference purposes, one of the standard atmospheric conditions for referee tests taken from 5.2 of IEC 60068-1 shall be selected and shall be as follows:

- temperature: 20 °C ± 2 °C;
- relative humidity: 60 % to 70 %;
- air pressure: 86 kPa to 106 kPa.

5 Measuring method of DC saturation limited current

5.1 General

When alternating current in which DC current is superimposed is supplied to an inductor, the inductance of the inductor decreases according to the DC current value.

In a typical application, the saturation current results from the peak current of the superposition of AC on DC current. In this standard, the saturation current is measured as DC current offsetting a small signal AC current.

NOTE It is not practical to set a standard for AC saturation limited current, because there are an unlimited number of different ways to apply AC current in an application. Therefore, manufacturers and users have generally defined DC saturation limited current as a common point of reference. This standard does the same.

5.2 Test conditions

Unless otherwise specified in the detail specification, the test conditions shall be in accordance with Clause 4.

NOTE The variation of the value of DC saturation limited current, as a function of temperature, is dependent on the magnetic material and the structure of the magnetic core of the inductor. However, measurement of DC saturating currents at elevated temperatures is generally not practical for inspection purposes. Therefore, the measurement at room temperature as provided by this standard is generally applied for specification purposes. Degrading curves indicating variation of DC saturation limited current as a function of maximum operating temperature of the inductor can be generated. These curves can be used to correlate the DC saturation limited current at room temperature to the DC saturation limited current at typical operating temperatures. In some cases, it will become necessary for the manufacturer and user to agree on an additional specification at a high temperature such as 85 °C, 105 °C or 125 °C.

5.3 Measurement circuit and calculation

a) Measuring circuit

The measuring circuit is as shown in Figure 1.

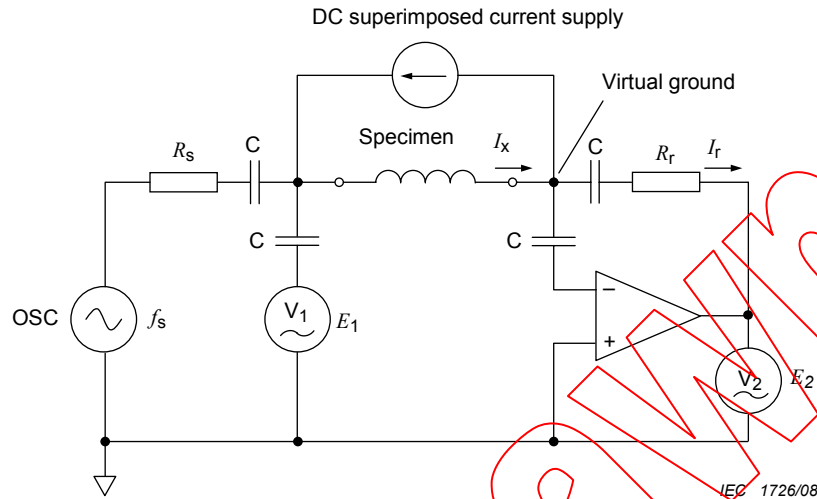

Components

R_s	source resistor $R = R_s$
R_r	range resistor $R = R_r$
V_1	voltmeter $V_1 = E_1$
V_2	voltmeter $V_2 = E_2$
C	DC current blocking capacitor

Supplies

f_s	frequency of source
I_r	supplied current to range resistor
I_x	supplied current to specimen
$I_x = I_r$	

Figure 1 – Inductance measurement circuit under application of DC saturation condition

b) Calculation

Voltages E_1 and E_2 shall be measured when frequency f_s and voltage E_s of the signal generator are supplied in accordance with the detail specification, and an initial value of the inductance shall be calculated by the following formulas.

$$Z_x = \frac{E_1}{I_r} = \frac{-E_1}{E_2} R_r$$

$$Z_x = |Z_x| \cos \theta + j |Z_x| \sin \theta$$

$$Z_x = R_x + jX_x$$

$$L_x = \frac{X_x}{\omega} = \frac{X_x}{2\pi f_s}$$

where

- R_x is the resistance of the specimen;
- X_x is the reactance of the specimen;
- Z_x is the impedance of the specimen;
- L_x is the equivalent series inductance of the specimen;
- E_1 is applied voltage to specimen;
- E_2 is applied voltage to range resistor ($= I_r R_r$) (E_2 can be regarded as current);
- θ is phase angle difference between E_1 and E_2 .

5.4 Attachment jig of inductor

Attachment jig of specimen shall be specified in the detail specification.

5.5 Measuring method

- a) Short compensation shall be done before measurement.
- b) The specimen shall be connected to the circuit shown in Figure 1, by using the attachment jig specified in 5.4.
- c) When the specimen is connected by soldering, it shall be left until it becomes cool enough.
- d) Voltages E_1 and E_2 shall be measured when frequency f_s and voltage E_s of the signal generator are supplied in accordance with the detail specification, and an initial value of the inductance shall be calculated by the formulas of 5.3 b).
- e) The value of the DC current that is superimposed on the specimen shall be modulated and the inductance value shall be measured.
- f) The decrease from the initial value of the inductance shall be calculated. DC saturation limited current shall be determined by measuring the DC current when the decrease in inductance matches the specified value in the detail specification.
- g) The decrease in inductance that is specified in the detail specification should be 10 % or 30 %.

NOTE 10 % is one of the design points typical for sharp-saturating inductors, and 30 % is one of the design points typical for soft-saturating inductors. See Annex A.

5.6 Quality conformance inspection

The DC current specified in the detail specification shall be supplied to a specimen in accordance with the methods specified in 5.3 to 5.5, and then inductance shall be measured. The decrease in inductance shall be within the specified value.

6 Measuring method of temperature rise limited current

6.1 General

When DC current is supplied to an inductor, the inductor generates heat by itself according to the supplied DC current value because of its DC current resistance.

NOTE 1 Temperature rise results from self-heating of the inductor. The sources of heating are DC copper losses, AC copper losses and AC core losses. This standard defines the temperature rise induced only by DC currents. In specific applications, it is necessary to consider AC copper losses and AC core losses for the temperature rise. AC losses are highly affected by waveform, amplitude and frequency.

NOTE 2 It is not practical to set a standard for AC temperature rise limited current, because there are an unlimited number of different ways to apply AC current in an application. In DC to DC converters, often AC loss is far smaller than DC loss. Therefore, manufacturers and users have generally defined DC temperature rise limited current as a common point of reference. This standard does the same.

6.2 Test conditions

Unless otherwise specified in the detail specification, the test conditions shall be in accordance with Clause 4.

Since the value of DC current resistance increases as a function of temperature, some applications require a high ambient temperature such as 85 °C, 105 °C or 125 °C for the temperature rise test.

NOTE 1 The overall power loss of an inductor is a combination of DC power loss due to DC current resistance, as well as AC power loss due to AC current in the windings and losses due to the corresponding AC flux induced in the magnetic core. The value of AC and DC current resistance (the conductor resistance) increases with temperature, thus the power loss associated with conductor resistance increases with temperature. The loss associated with the magnetic core is all due to AC excitation. The core loss decreases with increasing temperature up to a temperature typically referred to as the core loss minima temperature, above which point this loss begins to increase. The minima temperature and magnitude of loss is dependent on the magnetic material type and grade. Most ferrites exhibit sharp minima temperatures, while powder alloys do not. These considerations must be taken into account when applying temperature rise currents to applications with high operating temperatures and a non-trivial amount of AC power loss in addition to DC power loss. The overall total loss at any given temperature may be dominated by DC loss or AC loss dependent on the power loss distribution at room temperature as well as the variation of each of these power losses with temperature.

NOTE 2 Regarding DC temperature rise limited currents at high temperatures, the variation in DC temperature rise limited current with ambient temperature variation can be predicted. Moreover, measurement of DC temperature rise limited currents at elevated temperatures is generally not practical. Therefore, the measurement at room temperature as provided by this standard is generally applied.

6.3 Measurement jig

The measurement jig shall be either printed-wiring board method given in 6.3.1 or lead wire method given in 6.3.2, and shall be specified in the detail specification.

6.3.1 Printed-wiring board method

Printed-wiring board shall be made of epoxide woven glass (FR4). Unless otherwise specified in the detail specification, the dimensions shall be as shown in Table 1 and Figure 2.

Table 1 – Width of circuits

Rated current of inductor I A	Pattern width ^a W mm
$I \leq 1$	1,0 ± 0,2
$1 < I \leq 2$	2,0 ± 0,2
$2 < I \leq 3$	3,0 ± 0,3
$3 < I \leq 5$	5,0 ± 0,3
$5 < I \leq 7$	7,0 ± 0,5
$7 < I \leq 11$	11,0 ± 0,5
$11 < I \leq 16$	16,0 ± 0,5
$16 < I \leq 22$	22,0 ± 0,5
$22 < I$	According to the detail specification
^a See Figure 2.	