



Standard Specification for Aluminum-Alloy Permanent Mold Castings¹

This standard is issued under the fixed designation B 108; the number immediately following the designation indicates the year of original adoption or, in the case of revision, the year of last revision. A number in parentheses indicates the year of last reapproval. A superscript epsilon (ϵ) indicates an editorial change since the last revision or reapproval.

This standard has been approved for use by agencies of the Department of Defense.

1. Scope

1.1 This specification² covers aluminum-alloy permanent mold castings designated as shown in Table 1.

1.2 Alloy and temper designations are in accordance with ANSI H35.1. The equivalent unified numbering system alloy designations are in accordance with Practice E 527.

1.3 For acceptance criteria for inclusion of new aluminum and aluminum alloys and their properties in this specification, see Annex A1 and Annex A2.

1.4 The values stated in inch-pound units are to be regarded as the standard. The values given in parentheses are for information only.

2. Referenced Documents

2.1 The following documents of the issue in effect on the date of casting purchase form a part of this specification to the extent referenced herein:

2.2 ASTM Standards:

B 179 Specification for Aluminum Alloys in Ingot Form for Castings from all Casting Processes³

B 275 Practice for Codification of Certain Nonferrous Metals and Alloys, Cast and Wrought³

B 557 Test Methods for Tension Testing Wrought and Cast Aluminum- and Magnesium-Alloy Products³

B 597 Practice for Heat Treatment of Aluminum Alloys³

B 660 Practices for Packaging/Packing of Aluminum and Magnesium Products³

E 29 Practice for Using Significant Digits in Test Data to Determine Conformance with Specifications⁴

E 34 Test Methods for Chemical Analysis of Aluminum and Aluminum-Base Alloys⁵

E 88 Practice for Sampling Nonferrous Metals and Alloys in Cast Form for Determination of Chemical Composition⁵

E 94 Guide for Radiographic Testing⁶

E 155 Reference Radiographs for Examination of Aluminum and Magnesium Castings⁶

E 165 Test Method for Liquid Penetrant Examination⁶

E 227 Test Method for Optical Emission Spectrometric Analysis of Aluminum and Aluminum Alloys by the Point-to-Plane Technique⁵

E 527 Practice for Numbering Metals and Alloys (UNS)⁷

E 607 Test Method for Optical Emission Spectrometric Analysis of Aluminum and Aluminum Alloys by the Point-to-Plane Technique, Nitrogen Atmosphere⁸

E 716 Practices for Sampling Aluminum and Aluminum Alloys for Spectrochemical Analysis⁸

E 1251 Test Method for Optical Emission Spectrometric Analysis of Aluminum and Aluminum Alloys by the Argon Atmosphere, Point-to-Plane, Unipolar Self-Initiating Capacitor Discharge⁸

2.3 ANSI Standard:

H35.1 Alloy and Temper Designation Systems for Aluminum⁹

2.4 Military Standards:⁹

MIL-STD-129 Marking for Shipment and Storage

MIL-STD-276 Impregnation of Porous Nonferrous Metal Castings

MIL-STD-278 Welding and Allied Processes for Machinery for Ships

MIL-I-13857 Impregnation of Metal Castings

2.5 Federal Standard:¹⁰

Fed Std. No. 123 Marking for Shipment (Civil Agencies)

3. Terminology

3.1 Definitions:

3.1.1 *permanent mold casting*—a metal object produced by introducing molten metal by gravity or low pressure into a mold constructed of durable material, usually iron or steel, and allowing it to solidify.

¹ This specification is under the jurisdiction of ASTM Committee B07 on Light Metals and Alloys and is the direct responsibility of Subcommittee B07.01 on Aluminum Alloy Ingots and Castings.

Current edition approved May 10, 1999. Published July 1999. Originally published as B 108 – 36 T. Last previous edition B 108 – 98.

² For ASME Boiler and Pressure Code application see related SB-108.

³ *Annual Book of ASTM Standards*, Vol 02.02.

⁴ *Annual Book of ASTM Standards*, Vol 14.02.

⁵ *Annual Book of ASTM Standards*, Vol 03.05.

⁶ *Annual Book of ASTM Standards*, Vol 03.03.

⁷ *Annual Book of ASTM Standards*, Vol 01.01.

⁸ *Annual Book of ASTM Standards*, Vol 03.06.

⁹ Available from American National Standards Institute, 11 W. 42nd St., 13th Floor, NY 10036.

¹⁰ Available from Standardization Documents Order Desk, Bldg. 4, Section D, 700 Robbins Ave., Philadelphia, PA 19111-5094, Attn: NPODS.

TABLE 1 Chemical Composition Limits^{A,B,C}

| Alloy | | Composition, % | | | | | | | | | | | Other Elements ^E | |
|--------------------|--------|----------------|-----------|------------------|-----------|-------------------|----------------|-----------|---------|---------|---------|-----------|-----------------------------|--------------------|
| ANSI ^D | UNS | Aluminum | Silicon | Iron | Copper | Manga- nese | Magne- sium | Chromium | Nickel | Zinc | Tin | Titanium | Each | Total ^F |
| | | | | | | | | | | | | | | |
| 204.0 | A02040 | remainder | 0.20 | 0.35 | 4.2–5.0 | 0.10 | 0.15–0.35 | ... | 0.05 | 0.10 | 0.05 | 0.15–0.30 | 0.05 | 0.15 |
| 208.0 | A02080 | remainder | 2.5–3.5 | 1.2 | 3.5–4.5 | 0.50 | 0.10 | ... | 0.35 | 1.0 | ... | 0.25 | ... | 0.50 |
| 213.0 | A02130 | remainder | 1.0–3.0 | 1.2 | 6.0–8.0 | 0.6 | 0.10 | ... | 0.35 | 2.5 | ... | 0.25 | ... | 0.50 |
| 222.0 | A02220 | remainder | 2.0 | 1.5 | 9.2–10.7 | 0.50 | 0.15–0.35 | ... | 0.50 | 0.8 | ... | 0.25 | ... | 0.35 |
| 242.0 | A02420 | remainder | 0.7 | 1.0 | 3.5–4.5 | 0.35 | 1.2–1.8 | 0.25 | 1.7–2.3 | 0.35 | ... | 0.25 | 0.05 | 0.15 |
| 296.0 | | remainder | 2.0–3.0 | 1.2 | 4.0–5.0 | 0.35 | 0.05 | ... | 0.35 | 0.50 | ... | 0.25 | ... | 0.35 |
| 308.0 | | remainder | 5.0–6.0 | 1.0 | 4.0–5.0 | 0.50 | 0.10 | ... | ... | 1.0 | ... | 0.25 | ... | 0.50 |
| 319.0 | A03190 | remainder | 5.5–6.5 | 1.0 | 3.0–4.0 | 0.50 | 0.10 | ... | 0.35 | 1.0 | ... | 0.25 | ... | 0.50 |
| 332.0 ^G | A03320 | remainder | 8.5–10.5 | 1.2 | 2.0–4.0 | 0.50 | 0.50–1.5 | ... | 0.50 | 1.0 | ... | 0.25 | ... | 0.50 |
| 333.0 | A03330 | remainder | 8.0–10.0 | 1.0 | 3.0–4.0 | 0.50 | 0.05–0.50 | ... | 0.50 | 1.0 | ... | 0.25 | ... | 0.50 |
| 336.0 ^G | A03360 | remainder | 11.0–13.0 | 1.2 | 0.50–1.5 | 0.35 | 0.7–1.3 | ... | 2.0–3.0 | 0.35 | ... | 0.25 | 0.05 | ... |
| 354.0 | A03540 | remainder | 8.6–9.4 | 0.20 | 1.6–2.0 | 0.10 | 0.40–0.6 | ... | ... | 0.10 | ... | 0.20 | 0.05 | 0.15 |
| 355.0 | A03550 | remainder | 4.5–5.5 | 0.6 ^H | 1.0–1.5 | 0.50 ^H | 0.40–0.6 | 0.25 | ... | 0.35 | ... | 0.25 | 0.05 | 0.15 |
| C355.0 | A33550 | remainder | 4.5–5.5 | 0.20 | 1.0–1.5 | 0.10 | 0.40–0.6 | ... | ... | 0.10 | ... | 0.20 | 0.05 | 0.15 |
| 356.0 | A03560 | remainder | 6.5–7.5 | 0.6 ^H | 0.25 | 0.35 ^H | 0.20–0.45 | ... | ... | 0.35 | ... | 0.25 | 0.05 | 0.15 |
| A356.0 | A13560 | remainder | 6.5–7.5 | 0.20 | 0.20 | 0.10 | 0.25–0.45 | ... | ... | 0.10 | ... | 0.20 | 0.05 | 0.15 |
| 357.0 | | remainder | 6.5–7.5 | 0.15 | 0.05 | 0.03 | 0.45–0.6 | ... | ... | 0.05 | ... | 0.20 | 0.05 | 0.15 |
| A357.0 | A13570 | remainder | 6.5–7.5 | 0.20 | 0.20 | 0.10 | 0.40–0.7 | ... | ... | 0.10 | ... | 0.04–0.20 | 0.05 ^I | 0.15 |
| 359.0 | A03590 | remainder | 8.5–9.5 | 0.20 | 0.20 | 0.10 | 0.50–0.7 | ... | ... | 0.10 | ... | 0.20 | 0.05 | 0.15 |
| 443.0 | A04430 | remainder | 4.5–6.0 | 0.8 | 0.6 | 0.50 | 0.05 | 0.25 | ... | 0.50 | ... | 0.25 | ... | 0.35 |
| B443.0 | A24430 | remainder | 4.5–6.0 | 0.8 | 0.15 | 0.35 | 0.05 | ... | ... | 0.35 | ... | 0.25 | 0.05 | 0.15 |
| A444.0 | A14440 | remainder | 6.5–7.5 | 0.20 | 0.10 | 0.10 | 0.05 | ... | ... | 0.10 | ... | 0.20 | 0.05 | 0.15 |
| 513.0 ^G | A05130 | remainder | 0.30 | 0.40 | 0.10 | 0.30 | 3.5–4.5 | ... | ... | 1.4–2.2 | ... | 0.20 | 0.05 | 0.15 |
| 535.0 | A05350 | remainder | 0.15 | 0.15 | 0.05 | 0.10–0.25 | 6.2–7.5 | ... | ... | ... | ... | 0.10–0.25 | 0.05 ^J | 0.15 |
| 705.0 | A07050 | remainder | 0.20 | 0.8 | 0.20 | 0.40–0.6 | 1.4–1.8 | 0.20–0.40 | ... | 2.7–3.3 | ... | 0.25 | 0.05 | 0.15 |
| 707.0 | A07070 | remainder | 0.20 | 0.8 | 0.20 | 0.40–0.6 | 1.8–2.4 | 0.20–0.40 | ... | 4.0–4.5 | ... | 0.25 | 0.05 | 0.15 |
| 711.0 ^G | A07110 | remainder | 0.30 | 0.7–1.4 | 0.35–0.65 | 0.05 | 0.25–0.45 | ... | ... | 6.0–7.0 | ... | 0.20 | 0.05 | 0.15 |
| 713.0 | A07130 | remainder | 0.25 | 1.1 | 0.40–1.0 | 0.6 | 0.20–0.50 | 0.35 | 0.15 | 7.0–8.0 | ... | 0.25 | 0.10 | 0.25 |
| 850.0 | A08500 | remainder | 0.7 | 0.7 | 0.7–1.3 | 0.10 | 0.10 | ... | 0.7–1.3 | ... | 5.5–7.0 | 0.20 | ... | 0.30 |
| 851.0 ^G | A08510 | remainder | 2.0–3.0 | 0.7 | 0.7–1.3 | 0.10 | 0.10 | ... | 0.3–0.7 | ... | 5.5–7.0 | 0.20 | ... | 0.30 |
| 852.0 ^G | A08520 | remainder | 0.40 | 0.7 | 1.7–2.3 | 0.10 | 0.6–0.9 | ... | 0.9–1.5 | ... | 5.5–7.0 | 0.20 | ... | 0.30 |

^A When single units are shown, these indicate the maximum amounts permitted.

^B Analysis shall be made for the elements for which limits are shown in this table.

^C The following applies to all specified limits in this table: For purposes of determining conformance to these limits, an observed value or a calculated value obtained from analysis shall be rounded to the nearest unit in the last right-hand place of figures used in expressing the specified limit in accordance with the rounding method of Practice E 29.

^D ASTM alloy designations are recorded in Practice B 275.

^E *Others* includes listed elements for which no specific limit is shown as well as unlisted metallic elements. The producer may analyze samples for trace elements not specified in the specification. However, such analysis is not required and may not cover all metallic *Others* elements. Should any analysis by the producer or the purchaser establish that an *Others* element exceeds the limit of *Each* or that the aggregate of several *Others* elements exceeds the limit of *Total*, the material shall be considered nonconforming.

^F *Other Elements*—Total shall be the sum of unspecified metallic elements 0.010 % or more, rounded to the second decimal before determining the sum.

^G 336.0 formerly A332.0, 332.0 formerly F332.0, 513.0 formerly A514.0, 711.0 formerly C712.0, 851.0 formerly A850.0, 852.0 formerly B850.0.

^H If the iron content exceeds 0.45 %, manganese content shall not be less than one half of the iron.

^I Beryllium 0.04–0.07.

^J Beryllium 0.003–0.007, boron 0.005 max.

3.1.2 *semi-permanent mold casting*—a permanent mold casting which is made using an expendable core such as sand.

4. Ordering Information

4.1 Orders for material under this specification shall include the following information:

- 4.1.1 This specification designation (which includes the number, the year, and the revision letter, if applicable),
- 4.1.2 Alloy (see Section 7 and Table 1),
- 4.1.3 Temper (see Section 11 and Table 2),
- 4.1.4 Applicable drawing or part number,
- 4.1.5 The quantity in either pieces or pounds.

4.2 Additionally, orders for material to this specification shall include the following information when required by the purchaser.

- 4.2.1 Whether yield strength tests are required (see 11.1 and Table 2, Footnote F),
- 4.2.2 Whether castings or test bars, or both, are to be

artificially aged for Alloys 705.0-T5, 707.0-T5, and 713.0-T5 (see 11.3),

4.2.3 Whether test specimens cut from castings are required in addition to or instead of separately cast specimens (see Sections 11 and 15, and 13.2),

4.2.4 Whether repairs are permissible (see Section 18),

4.2.5 Whether inspection is required at the producer's works (see Section 19),

4.2.6 Whether certification is required (see Section 23),

4.2.7 Whether surface requirements will be checked visually or by observational standards where such standards are established (see 20.1),

4.2.8 Whether liquid penetrant inspection is required (see 20.2),

4.2.9 Whether radiographic inspection is required (see 20.3), and

4.2.10 Whether foundry control is required (see 10.2).

4.2.11 Whether the material shall be packaged, or marked, or both, in accordance with Practices B 660, MIL-STD-129, and Fed. Std. No. 123 (see 24.4).

TABLE 2 Tensile Requirements^{A,B}

| Alloy | | Temper ^C | Tensile Strength, min, ksi (MPa) ^E | Yield Strength ^D (0.2 % offset), min, ksi (MPa) ^E | Elongation in 2 in. or 4 × Diameter, min, % | Typical Brinell Hardness ^F 500-kgf load, 10-mm ball |
|-------------------|--------|-----------------------------------------------|-----------------------------------------------|-------------------------------------------------------------------------|---------------------------------------------|----------------------------------------------------------------|
| ANSI ^G | UNS | | | | | |
| 204.0 | A02040 | T4 separately cast specimens | 48.0 (331) | 29.0 (200) | 8.0 | ... |
| 208.0 | A02080 | T4 | 33.0 (228) | 15.0 (103) | 4.5 | 75 |
| | | T6 | 35.0 (241) | 22.0 (152) | 2.0 | 90 |
| | | T7 | 33.0 (228) | 16.0 (110) | 3.0 | 80 |
| 213.0 | A02130 | F | 23.0 (159) | ... | ... | ... |
| 222.0 | A02220 | T551 | 30.0 (207) | ... | H | 115 |
| | | T65 | 40.0 (276) | ... | H | 140 |
| 242.0 | A02420 | T571 | 34.0 (234) | ... | H | 105 |
| | | T61 | 40.0 (276) | ... | H | 110 |
| 319.0 | A03190 | F | 27.0 (186) | 14.0 (97) | 2.5 | 95 |
| 336.0' | A03360 | T551 | 31.0 (214) | ... | H | 105 |
| | | T65 | 40.0 (276) | ... | H | 125 |
| 332.0' | A03320 | T5 | 31.0 (214) | ... | H | 105 |
| 333.0 | A03330 | F | 28.0 (193) | ... | H | 90 |
| | | T5 | 30.0 (207) | ... | H | 100 |
| | | T6 | 35.0 (241) | ... | H | 105 |
| | | T7 | 31.0 (214) | ... | H | 90 |
| 354.0 | A03540 | T61 | | | | |
| | | separately cast specimens | 48.0 (331) | 37.0 (255) | 3.0 | |
| | | castings, designated area ^J | 47.0 (324) | 36.0 (248) | 3.0 | |
| | | castings, no location designated ^J | 43.0 (297) | 33.0 (228) | 2.0 | |
| | | T62 | | | | |
| | | separately cast specimens | 52.0 (359) | 42.0 (290) | 2.0 | |
| | | castings, designated area ^J | 50.0 (344) | 42.0 (290) | 2.0 | |
| | | castings, no location designated ^J | 43.0 (297) | 33.0 (228) | 2.0 | |
| 355.0 | A03550 | T51 | 27.0 (186) | ... | H | 75 |
| | | T62 | 42.0 (290) | ... | H | 105 |
| | | T7 | 36.0 (248) | ... | H | 90 |
| | | T71 | 34.0 (234) | 27.0 (186) | H | 80 |
| C355.0 | A33550 | T61 | | | | |
| | | separately cast specimens | 40.0 (276) | 30.0 (207) | 3.0 | 85–90 |
| | | castings, designated area ^J | 40.0 (276) | 30.0 (207) | 3.0 | |
| | | castings, no location designated ^J | 37.0 (255) | 30.0 (207) | 1.0 | 85 |
| 356.0 | A03560 | F | 21.0 (145) | 10.0 (69) | 3.0 | |
| | | T6 | 33.0 (228) | 22.0 (152) | 3.0 | 85 |
| | | T71 | 25.0 (172) | ... | 3.0 | 70 |
| A356.0 | A13560 | T61 | | | | |
| | | separately cast specimens | 38.0 (262) | 26.0 (179) | 5.0 | 80–90 |
| | | castings, designated area ^J | 33.0 (228) | 26.0 (179) | 5.0 | |
| | | castings, no location designated ^J | 28.0 (193) | 26.0 (179) | 3.0 | |
| 357.0 | | T6 | 45.0 (310) | ... | 3.0 | ... |
| A357.0 | A13570 | T61 | | | | |
| | | separately cast specimens | 45.0 (310) | 36.0 (248) | 3.0 | 100 |
| | | castings, designated area ^J | 46.0 (317) | 36.0 (248) | 3.0 | ... |
| | | castings, no location designated ^J | 41.0 (283) | 31.0 (214) | 3.0 | ... |
| 359.0 | A03590 | T61 | | | | |
| | | separately cast specimens | 45.0 (310) | 34.0 (234) | 4.0 | 90 |
| | | castings, designated area ^J | 45.0 (310) | 34.0 (234) | 4.0 | |
| | | castings, no location designated ^J | 40.0 (276) | 30.0 (207) | 3.0 | |
| | | T62 | | | | |
| | | separately cast specimens | 47.0 (324) | 38.0 (262) | 3.0 | 100 |
| | | castings, designated area ^J | 47.0 (324) | 38.0 (262) | 3.0 | |
| | | castings, no location designated ^J | 40.0 (276) | 30.0 (207) | 3.0 | |
| 443.0 | A04430 | F | 21.0 (145) | 7.0 (49) | 2.0 | 45 |
| B443.0 | A24430 | F | 21.0 (145) | 6.0 (41) | 2.5 | 45 |
| A444.0 | A14440 | T4 | | | | |
| | | separately cast specimens | 20.0 (138) | ... | 20 | ... |
| | | castings, designated area ^E | 20.0 (138) | ... | 20 | ... |
| 513.0' | A05130 | F | 22.0 (152) | 12.0 (83) | 2.5 | 60 |
| 535.0 | A05350 | F | 35.0 (241) | 18.0 (124) | 8.0 | ... |
| 705.0 | A07050 | T1 or T5 | 37.0 (255) | 17.0 (117) | 10.0 | |
| 707.0 | A07070 | T1 | 42.0 (290) | 25.0 (173) | 4.0 | |
| | | T7 | 45.0 (310) | 35.0 (241) | 3.0 | |
| 711.0' | A07110 | T1 | 28.0 (193) | 18.0 (124) | 7.0 | 70 |
| 713.0 | A07130 | T1 or T5 | 32.0 (221) | 22.0 (152) | 4.0 | |

TABLE 2 Continued

| Alloy | | Temper ^C | Tensile Strength, min, ksi (MPa) ^E | Yield Strength ^D (0.2 % offset), min, ksi (MPa) ^E | Elongation in 2 in. or 4 × Diameter, min, % | Typical Brinell Hardness ^F 500-kgf load, 10-mm ball |
|--------------------|--------|---------------------|-----------------------------------------------|-------------------------------------------------------------------------|---------------------------------------------|----------------------------------------------------------------|
| ANSI ^G | UNS | | | | | |
| 850.0 | A08500 | T5 | 18.0 (124) | ... | 8.0 | |
| 851.0 ^I | A08510 | T5 | 17.0 (117) | ... | 3.0 | |
| | | T6 | 18.0 (124) | ... | 8.0 | |
| 852.0 ^I | A08520 | T5 | 27.0 (186) | ... | 3.0 | |

^A If agreed upon by manufacturer and the purchaser, other mechanical properties may be obtained by other heat treatments such as annealing, aging, or stress relieving.

^B For purposes of determining conformance with this specification, each value for tensile strength and yield strength shall be rounded off to the nearest 0.1 ksi, and each value for elongation shall be rounded to the nearest 0.5 %, both in accordance with the rounding method of Practice E 29.

^C Temper designations:

F As fabricated.

O Annealed.

T1 Cooled from an elevated temperature shaping process and naturally aged to a substantially stable condition.

T4 Solution heat-treated and naturally aged to a substantially stable condition.

T5 Cooled from an elevated temperature shaping process and then artificially aged.

T6 Solution heat-treated and then artificially aged.

T7 Solution heat-treated and stabilized.

Additional digits, the first of which shall not be zero, may be added to designations T1 through T10 to indicate a variation in treatment that significantly alters the characteristics of the product.

^D Yield strength to be evaluated only when specified in contract or purchase order.

^E S1 units for information only. For explanation of the S1 Unit "MPa" see Appendix X2.

^F Hardness values given for information only, not required for acceptance.

^G ASTM alloy designations are recorded in Practice B 275.

^H Not required.

^I 336.0 formerly A332.0, 332.0 formerly F332.0, 513.0 formerly A514.0, 711.0 formerly C712.0, 851.0 formerly A850.0, 852.0 formerly B850.0.

^J These properties apply only to castings having section thicknesses not greater than 2 in. except that section thicknesses of ¾ in., max, shall apply to Alloy A444.0.

5. Responsibility for Quality Assurance

5.1 Unless otherwise specified in the contract or purchase order, the producer shall be responsible for the performance of all inspections and test requirements specified herein. Unless otherwise agreed upon, the producer may use his own or any other suitable facilities for the performance of the inspection and test requirements specified herein. The purchaser shall have the right to perform any of the inspections and tests set forth in the specification where such inspections are deemed necessary to confirm that material conforms to prescribed requirements.

6. Materials and Manufacture

6.1 The responsibility of furnishing castings that can be laid out and machined to the finished dimensions within the permissible variations specified, as shown on the blueprints or drawings, shall rest with the producer, except where mold equipment is furnished by the purchaser.

7. Chemical Composition

7.1 The castings shall conform to the chemical composition limits prescribed in Table 1. Conformance shall be determined by the producer by analyzing samples at the time the castings are poured, or samples taken from castings or tension test specimens representative of the castings. If the producer has determined the chemical composition of the material during the course of manufacture, he shall not be required to sample and analyze the finished product.

8. Sampling for Determination of Chemical Composition

8.1 A sample for determination of chemical composition shall be taken to represent one of the following:

8.1.1 Not more than 4000 lb (1814 kg) of clean castings (gates and risers removed) or a single casting poured from one furnace.

8.1.2 The castings poured continuously from one furnace in not more than eight consecutive hours.

8.2 Samples for determination of chemical composition shall be taken in accordance with one of the following methods:

8.2.1 *Samples for Chemical Analysis*— Samples for chemical analysis shall be taken by sawing, drilling, or milling the casting or test specimens in such a manner as to be representative of the material (Practice E 88). The weight of a prepared sample shall not be less than 75 g.

8.2.2 *Samples for Spectrochemical and Other Methods of Analysis*—Samples for spectrochemical analysis shall be taken in accordance with Practices E 716. Samples for other methods of analysis shall be suitable for the form of material being analyzed and the type of analytical methods used.

9. Methods for Determination of Chemical Composition

9.1 The determination of chemical composition shall be made in accordance with suitable chemical (Test Methods E 34), or spectrochemical (Test Methods E 227, E 607 and E 1251), methods. Other methods may be used only when no published ASTM method is available. In case of dispute, the method of analysis shall be agreed upon by the producer and the purchaser.

10. Requirements for Castings Produced for Governmental and Military Agencies

10.1 *Material Requirements:*

10.1.1 Unless otherwise specified, only aluminum alloy conforming to the requirements of Specification B 179 or producers foundry scrap, identified as being made from alloy conforming to Specification B 179, shall be used in the remelting furnace from which molten metal is taken for pouring directly into castings. Additions of small amounts of modifying and grain refining elements or alloys are permitted.

10.1.2 Pure materials, recycled materials, and master alloys may be used to make alloys conforming to this specification, provided chemical analysis can be taken and adjusted to conform to Table 1 prior to pouring any castings.

10.2 *Foundry Control*—When specified, castings shall be produced under foundry control approved by the purchaser. Foundry control shall consist of examination of castings by radiographic or other approved methods for determining internal discontinuities until the gating, pouring, and other foundry practices have been established to produce castings meeting the quality standards furnished by the purchaser or agreed upon by the purchaser and the producer. When foundry practices have been so established, the production method shall not be significantly changed without demonstrating to the satisfaction of the purchaser that the change does not adversely affect the quality of the castings. Minor changes of $\pm 50^{\circ}\text{F}$ ($\pm 28^{\circ}\text{C}$) from the established nominal temperature are permissible.

11. Tensile Requirements

11.1 The separately cast tension test specimens representing the castings shall meet the mechanical properties prescribed in Table 2.

11.2 When specified, the tensile strength and elongation of test specimens cut from castings shall be in accordance with Table 2 for Alloys 354.0, C355.0, A356.0, A357.0, and A444.0. For other alloys a minimum of 75 % of the tensile and yield strength values and not less than 25 % of the elongation values specified in Table 2 are required. The measurement of elongation is not required for test specimens cut from castings if 25% of the specified minimum elongation value published in Table 2 is 0.5 % or less. If grade D quality castings as described in Table 3 are specified, no tensile tests shall be specified nor tensile requirements be met on specimens cut from castings.

11.3 Although Alloys 705.0, 707.0, and 713.0 are most frequently used in the naturally aged condition, by agreement of the producer and the purchaser, the castings may be artificially aged. The producer and the purchaser may also agree to base the acceptance of castings on artificially aged test bars. The conditions of artificial aging shown in Practice B 597 shall be employed unless other conditions are accepted by mutual consent.

12. Test Specimens

12.1 Separately cast test specimens shall be cast in iron molds. A recommended gating method is shown in Fig. 1. The test section of the tension test specimen shall be cast to size in accordance with the dimensions shown in Fig. 1 and not machined prior to test. Grip ends may be machined to adapt them in such a manner as to ensure axial loading.

12.2 When properties of castings are to be determined, tension test specimens shall be cut from the locations designated on the drawings, unless otherwise negotiated. If no locations are designated, one or more specimens shall be taken to include locations having significant variation in casting thickness, except that specimens shall not be taken from areas directly under risers. The tension test specimens shall be the standard 0.500-in. diameter specimens shown in Fig. 9 of Test Methods B 557 or a round specimen of smaller size proportional to the standard specimens. In no case shall the dimensions of the smallest specimen be less than the following:

- Diameter of reduced section, 0.250 in.
- Length of reduced section, 1 1/4 in.
- Radius of fillet, 3/16 in.
- Diameter of end section, 3/8 in.
- Overall length:
 - With shouldered ends, 2 3/8 in.
 - With threaded ends, 3 in.
 - With plain cylindrical ends, 4 in.

12.3 When necessary, a rectangular specimen may be used proportional to that shown for the 0.500 in. wide specimen in Fig. 6 of Test Methods B 557, but in no case shall its dimensions be less than the following:

- Width of reduced section, 1/4 in.
- Length of reduced section, 1 1/4 in.
- Radius of fillet, 1/4 in.
- Overall length, 4 in.

The specified elongation values shall not apply to tests of rectangular specimens.

12.4 If the castings are to be heat treated and separately cast specimens are to be used, the specimens representing such castings shall be heat treated with the castings they represent. If castings are to be heat treated and tests are to be obtained on

TABLE 3 Discontinuity—Level Requirements for Aluminum Castings in Accordance with Reference Radiographs E 155

| Discontinuity | Grade A ^A | | Grade B | | Grade C | | Grade D | |
|----------------------------------------|-----------------------------|--------------|---------------|---------------------------------|---------------|--------------|---------------|--|
| | Section Thickness, in. (mm) | | | | | | | |
| | 1/4to 3/4 (6.4 to 19.0) | 1/4 (6.4) | 3/4 (19.0) | 1/4 (6.4) | 3/4 (19.0) | 1/4 (6.4) | 3/4 (19.0) | |
| Gas holes | none | 1 | 1 | 2 | 2 | 5 | 5 | |
| Gas porosity (round) | none | 1 | 1 | 3 | 3 | 7 | 7 | |
| Gas porosity (elongated) | none | 1 | 1 | 3 | 4 | 5 | 5 | |
| Shrinkage cavity | none | 1 | ^B | 2 | ^B | 3 | ^B | |
| Shrinkage porosity or sponge | none | 1 | 1 | 2 | 2 | 4 | 3 | |
| Foreign material (less dense material) | none | 1 | 1 | 2 | 2 | 4 | 4 | |
| Foreign material (more dense material) | none | 1 | 1 | 2 | 1 | 4 | 3 | |
| Segregation | none | | none | | none | | none | |
| Cracks | none | | none | | none | | none | |
| Cold shuts | none | | none | | none | | none | |
| Surface irregularity | | | | not to exceed drawing tolerance | | | | |
| Core shaft | | | | not to exceed drawing tolerance | | | | |

^A Caution should be exercised in requesting grade A because of the difficulty in obtaining this level.

^B No radiographs available.

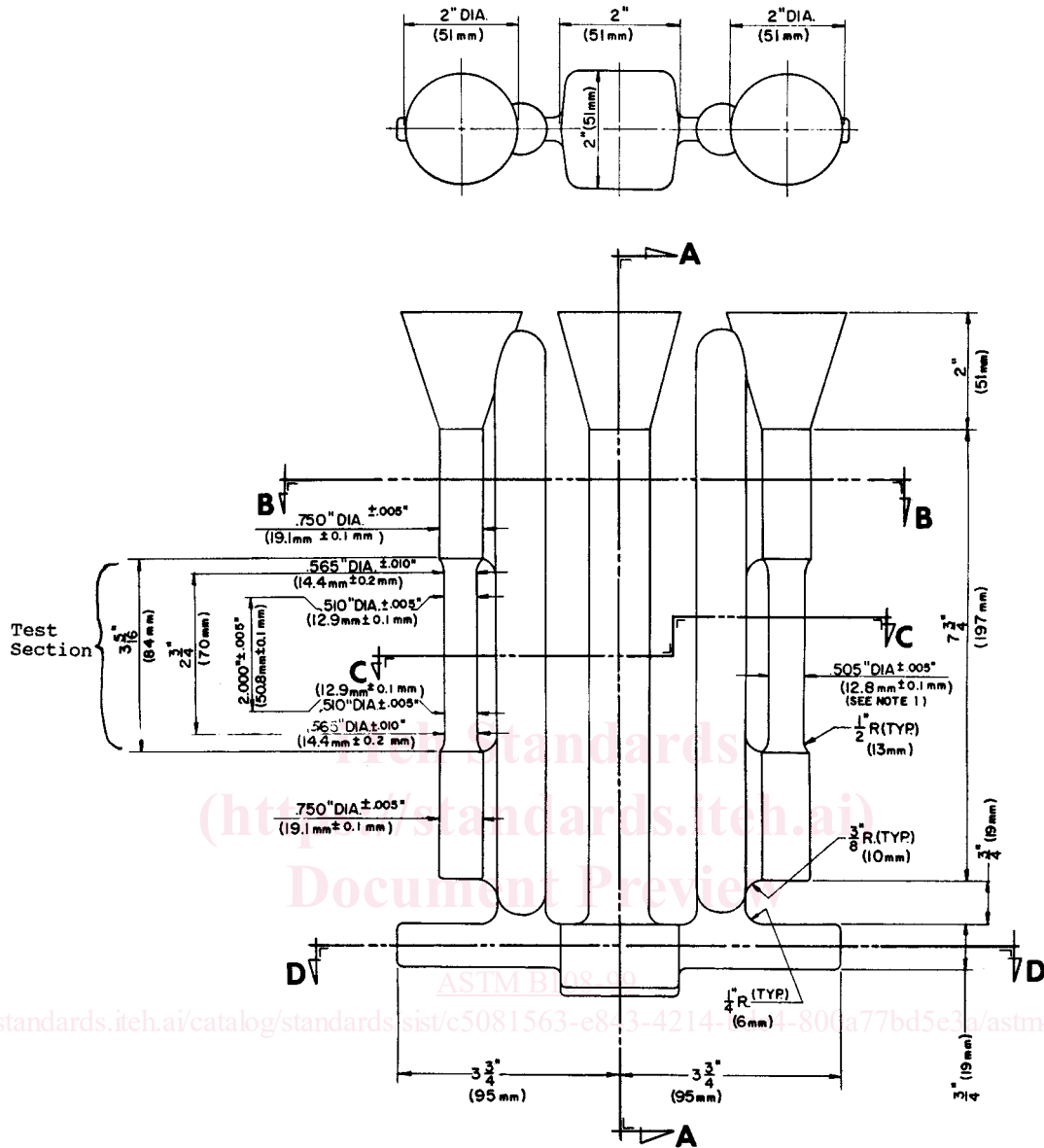

Nominal draft angle to be 20° on all square or rectangular sections in direction transverse to parting line.

NOTE 1—Test section of test bar: this section to be gradually tapered from the ends towards the center.

FIG. 1 Tension Test Specimen Casting

the castings, the test specimens shall be taken from the castings after heat treatment.

13. Number of Tests

13.1 Unless otherwise agreed upon by the purchaser and producer, two tension test specimens shall be separately cast and tested to represent the following:

13.1.1 Not more than 4000 lb (1814 kg) of clean castings (gates and risers removed) or a single casting poured from one furnace.

13.1.2 The castings poured continuously from one furnace in not more than eight consecutive hours.

13.2 When tensile properties of castings are to be determined, one per melt-heat combination shall be tested unless otherwise shown on the drawing or specified in the purchase order.

13.3 If any test specimen shows defective machining or flaws, it may be discarded, in which case the purchaser and the producer shall agree upon the selection of a replacement specimen.

14. Test Methods

14.1 The tensile properties shall be determined in accordance with Test Methods B 557.

15. Retests

15.1 If the results of the tension test do not conform to the requirements prescribed in Table 2, test bars representative of the castings may be retested in accordance with the replacement tests and retest provisions of Test Methods B 557 and the results of retests shall conform to the requirements as to mechanical properties specified in Table 2.