



Standard Practice for Steel Castings, Welding, Qualifications of Procedures and Personnel¹

This standard is issued under the fixed designation A 488/A 488M; the number immediately following the designation indicates the year of original adoption or, in the case of revision, the year of last revision. A number in parentheses indicates the year of last reapproval. A superscript epsilon (ϵ) indicates an editorial change since the last revision or reapproval.

This standard has been approved for use by agencies of the Department of Defense.

1. Scope

1.1 This practice establishes the qualification of procedures, welders, and operators for the fabrication and repair of steel castings by electric arc welding.

1.1.1 Qualifications of a procedure and either or both the operator or welder under Section IX of the ASME Boiler and Pressure Vessel Code shall automatically qualify the procedure and either or both the operator or welder under this practice. P-number designations in the ASME grouping of base metals for qualification may be different than the category numbers listed in Table 1. Refer to Appendix X1 for a comparison of ASTM category numbers with the corresponding ASME P-Number designations.

1.2 Each manufacturer or contractor is responsible for the welding done by his organization and shall conduct the tests required to qualify his welding procedures, welders, and operators.

1.3 Each manufacturer or contractor shall maintain a record of welding procedure qualification tests (Fig. 1), welder or operator performance qualification tests (Fig. 2), and welding procedure specification (Fig. 3), which shall be made available to the purchaser's representative on request.

1.4 The values stated in either inch-pound units or SI units are to be regarded separately as standard. Within the text, the SI units are shown in brackets. The values stated in each system are not exact equivalents; therefore, each system must be used independently of the other. Combining values from the two systems may result in nonconformance with this practice.

1.5 *This standard does not purport to address all of the safety concerns, if any, associated with its use. It is the responsibility of the user of this standard to establish appropriate safety and health practices and determine the applicability of regulatory limitations prior to use.*

2. Referenced Documents

2.1 ASTM Standards:

A 27/A 27M Specification for Steel Castings, Carbon, for

General Application²

A 148/A 148M Specification for Steel Castings, High Strength, for Structural Purposes²

A 216/A 216M Specification for Steel Castings, Carbon, Suitable for Fusion Welding, for High-Temperature Service²

A 217/A 217M Specification for Steel Castings, Martensitic Stainless and Alloy, for Pressure-Containing Parts, Suitable for High-Temperature Service²

A 351/A 351M Specification for Castings, Austenitic, Austenitic-Ferritic (Duplex), for Pressure-Containing Parts²

A 352/A 352M Specification for Steel Castings, Ferritic and Martensitic, for Pressure-Containing Parts, Suitable for Low-Temperature Service²

A 356/A 356M Specification for Steel Castings, Carbon, Low Alloy, and Stainless Steel, Heavy-Walled for Steam Turbines²

A 370 Test Methods and Definitions for Mechanical Testing of Steel Products³

A 389/A 389M Specification for Steel Castings, Alloy, Specially Heat-Treated, for Pressure-Containing Parts, Suitable for High-Temperature Service²

A 447/A 447M Specification for Steel Castings, Chromium-Nickel-Iron Alloy (25-12 Class), for High-Temperature Service²

A 487/A 487M Specification for Steel Castings Suitable for Pressure Service²

A 494/A 494M Specification for Castings, Nickel and Nickel Alloy²

A 732/A 732M Specification for Castings, Investment, Carbon and Low Alloy Steel for General Application, and Cobalt Alloy for High Strength at Elevated Temperatures²

A 743/A 743M Specification for Castings, Iron-Chromium, Iron-Chromium-Nickel, Corrosion-Resistant, for General Application²

A 744/A 744M Specification for Castings, Iron-Chromium-Nickel, Corrosion-Resistant, for Severe Service²

A 747/A 747M Specification for Steel Castings, Stainless, Precipitation Hardening²

¹ This practice is under the jurisdiction of ASTM Committee A01 on Steel, Stainless Steel and Related Alloys and is the direct responsibility of Subcommittee A01.18 on Castings.

Current edition approved Mar. 10, 2001. Published May 2001. Originally published as A 488 – 63 T. Last previous edition A 488/A 488M – 99.

² *Annual Book of ASTM Standards*, Vol 01.02.

³ *Annual Book of ASTM Standards*, Vol 01.03.

ASTM A 488/A 488M

RECOMMENDED FORM FOR MANUFACTURER'S RECORD OF WELDING PROCEDURE QUALIFICATION TESTS

Procedure No. _____ Date: _____ Welding Process: _____
 Material Specification: _____ to _____ of category No. _____ to category No. _____
 Plate Thickness: _____ Thickness Range Qualified _____
 Filler Metal F Group No. _____ Weld Deposit A-Group No.: _____
 Flux Designation: _____ Gas Composition: _____
 Gas Flow Rate: _____ Backing Strip, if any: _____
 Preheat Temperature Range: _____ Single or Multiple Pass: _____
 Position of Groove: _____ Filler Wire Diameter: _____
 Trade Name: _____ Type of Backing: _____
 Forehand or Backhand: _____ Amps: _____ Volts _____ Inches/min: _____
 Postheat Temperature _____ Time at Temperature _____

TENSION TEST RESULTS

Specimen No.	Width	Dimensions Thickness	Area	Ultimate Total Load, lb	Ultimate Unit Stress, psi	Nature of Failure and Location
--------------	-------	----------------------	------	-------------------------	---------------------------	--------------------------------

GUIDED BEND TEST RESULTS

Specimen No.	Results	Specimen No.	Results
--------------	---------	--------------	---------

Welder's Name: _____ Clock No. _____ Stamp No. _____

Who by virtue of these tests meets the welder performance qualification.

Test Conducted By: _____ Test No. _____
 per _____

We certify that the statements in this record are correct and that the test welds were prepared, welded, and tested in accordance with the requirements of ASTM Standard _____

Signed: _____

Manufacturer or Contractor

Date: _____

FIG. 1 Report Form 1

RECOMMENDED FORM FOR MANUFACTURER'S OR CONTRACTOR'S RECORD OF WELDER OR OPERATOR PERFORMANCE QUALIFICATION TESTS

Welder or Operator's Name: Stamp No. _____
 Clock No. _____ Welding Process: _____
 Position: _____
 In accordance with Procedure No. _____
 Material Specification: _____ to _____ of category No. _____ to category No. _____
 Plate Thickness: _____ Range of Thickness Qualified: _____
 Filler Metal Specification No. _____ Group No. F. _____
 Filler Metal A-Group No. _____ Filler Metal Diameter _____
 Trade Name: _____ Flux Designation or Gas Analysis: _____
 Was Backing Strip Used? _____

GUIDED BEND TEST RESULTS

Specimen No.	Results	Specimen No.	Results
--------------	---------	--------------	---------

Test Conducted By: _____ Laboratory Test No. _____
 per _____

We certify that the statements in this record are correct and that the test welds were prepared, welded, and tested in accordance with ASTM Standard _____

Signed: _____

Manufacturer or Contractor

Date: _____

FIG. 2 Report Form 2

A 757/A 757M Specification for Steel Castings, Ferritic and Martensitic, for Pressure-Containing and Other Appli-

cations, for Low-Temperature Service²
 A 872/A 872M Specification for Centrifugally Cast

REPORT FORM 3

RECOMMENDED FORM FOR WELDING PROCEDURE SPECIFICATION

1. Title

Welding of ^A _____ steel castings.

^A Indicate general material description, such as carbon, Cr-Mo, 12 Cr, etc.

2. Specification No. _____ Rev. _____

Date _____

3. Scope

3.1 Procedure Specification No. _____ covers the welding of ^A _____ steel castings using the ^B _____ welding process.

^A Indicate general material description as in Title.

^B Indicate specific welding process, such as shielded metal arc, gas metal arc, etc.

4. Base Material

4.1 The base material shall conform to the specifications for ^A _____ which is found in materials category number ^B _____.

^A Insert here reference to ASTM designation or indicate chemical analysis and physical properties.

^B Indicate category number from Table 1.

4.2 Base material shall be in the ^A _____ heat treated condition before welding.

^A Indicate heat treatment before welding.

5. Filler Metal

5.1 The filler metal shall conform to ANSI/AWS Specification ^A _____ which is found in weld metal analysis group A ^B _____.

^A Indicate appropriate American Welding Society specification number and filler metal classification (e.g., A5.1 E7018).

^B Indicate A Number from Table 4.

5.2 Flux for submerged arc welding shall conform to the following nominal composition: ^A _____.

^A Indicate chemical composition or trade designation.

5.3 Shielding gas for gas shielded arc welding shall conform to the following nominal composition: ^A _____.

^A Indicate the single gas or proportional parts of mixed gases and flow rates.

6. Preparation of Base Material

6.1 Metal removal shall be performed by ^A _____.

^A Indicate method of metal removal, such as chipping, grinding, carbon arc cutting, flame cutting etc. Also indicate whether preheat is required during metal removal.

6.2 Configuration of the weld preparation for partial penetration welds shall conform to the following geometry: ^A _____.

^A Indicate minimum root radius and minimum side wall angle.

6.3 Configuration of the weld preparation for full penetration welds shall conform to the following geometry: ^A _____.

^A Indicate minimum side wall angle.

6.4 Backing plates shall be used for welding full penetration welds. Backing plates shall be made from ^A _____ steel and shall fit the back of the cavity with a minimum gap of ^B _____.

^A Indicate material of backing plate.

^B Indicate dimension of maximum gap.

6.5 Surfaces of the weld preparation shall be cleaned of all oil, grease, dirt, scale, slag, shot blasting grit, or any foreign material which may be harmful to the quality of the weld. Surfaces of backing plates when used shall also meet the same cleanliness requirements.

6.6 All surfaces of the weld preparation shall be inspected as follows: ^A _____.

^A Indicate type of inspection.

7. Preheat

7.1 Preheat and interpass temperature shall be maintained in the range from ^A _____ to ^B _____ during ^C _____.

^A Indicate minimum temperature.

^B Indicate maximum temperature.

^C Indicate if preheat maintenance is during welding or until postweld heat treatment is performed.

7.2 Preheat for tack welding of backing plates is the same as required for welding.

7.3 Minimum temperature before applying heat shall be ^A _____.

^A Indicate temperature.

7.4 Local preheating to the temperatures indicated may be performed so that the heated area completely surrounds the weld preparation for a minimum distance of ^A _____ in any direction.

^A Indicate minimum distance for local preheating.

8. Welding Position

8.1 Welds shall be made in the ^A _____ position.

^A Indicate position or positions in which the welding will be performed. See Fig. 4.

9. Electrical Characteristics

9.1 The current used shall be _____ ^A. The base material shall be attached to the _____ ^B welding electrode lead.

^A Indicate whether direct or alternating current. If direct, state whether non-pulsed or pulsed. If pulsed, state frequency.

^B Indicate whether electrode positive (EP) or electrode negative (EN) output terminal of power supply is used.

Electrode Wire Diameter ^A	Amperage ^A	Range ^A	Voltage ^A
_____	_____	_____	_____
_____	_____	_____	_____
_____	_____	_____	_____

^A Indicate for each diameter of electrode, the amperage, the range of amperage permitted, and the voltage requirements. For welding processes using wire, indicate wire diameter, wire feed speed, and current requirements.

9.3 Electrodes subject to moisture absorption must be stored and handled to maintain dryness according to the following: ^A _____.

^A Where applicable, indicate electrode care instructions.

10. Welding Details

10.1 The width of any pass of welding shall not exceed ^A _____ times the size of the filler metal used.

^A Indicate the number for controlling the maximum width.

10.2 Craters shall be properly filled before each interruption of the arc.

10.3 Slag or flux shall be removed on any bead before depositing the next successive bead.

10.4 Interpass inspection shall be performed according to the following: ^A _____.

^A Indicate degree of interpass inspection required.

10.5 Peening shall be performed according to the following: ^A _____.

^A Indicate the degree of peening required. Indicate any limits on peening first and last layers.

11. Post-Weld Heat Treatment

11.1 Post-weld heat treatment shall consist of the following: ^A _____.

^A Indicate the heating and cooling rates, holding temperatures and times.

12. Inspection

12.1 Inspection of the completed weld shall be performed according to the following: ^A _____.

^A Indicate degree of inspection.

FIG. 3 Report Form 3

 **A 488/A 488M**

Ferritic/Austenitic Stainless Steel Pipe for Corrosive Environments⁴
 A 890/A 890M Specification for Castings, Iron-Chromium-Nickel-Molybdenum Corrosion-Resistant, Duplex (Austenitic/Ferritic) for General Application²
 A 990/A 990M Specification for Castings, Iron-Nickel-Chromium and Nickel Alloys, Specially Controlled for Pressure Retaining Parts for Corrosive Service²
 A 995/A 995M Specification for Castings, Austenitic-

Ferritic (Duplex) Stainless Steel, for Pressure-Containing Parts²
 2.2 American Society of Mechanical Engineers: ASME Boiler and Pressure Vessel Code, Section IX⁵
 2.3 American Welding Society: ANSI/AWS 3.0 Definitions for Welding and Cutting⁶

⁵ Available from the American Society of Mechanical Engineers, 345 E. 47th St., New York, NY 10017.

⁶ Available from the American Welding Society, 550 NW LeJeune Rd., P.O. Box 351040, Miami, FL 33135.

⁴ Annual Book of ASTM Standards, Vol 01.01.

TABLE 1 Categories of Base Materials

Category Number	Material Description	ASTM Specification	Grades
1	Carbon steel (carbon less than 0.35 %, tensile strength less than or equal to 70 ksi [480 MPa]).	A 27/A 27M	all grades
		A 216/A 216M	WCA, WCB
		A 352/A 352M	LCB, LCA
		A 356/A 356M	1
		A 732/A 732M	1A, 2A
2	Carbon steel (tensile strength greater than 70 ksi [480 MPa]). Carbon-manganese steel (tensile strength equal to or greater than 70 ksi but less than 90 ksi [620 MPa]).	A 148/A 148M	80-40
		A 216/A 216M	WCC
		A 352/A 352M	LCC
		A 732/A 732M	2Q, 3A
		A 757/A 757M	A2Q
3	Carbon and carbon-manganese steel (tensile strength equal to or greater than 90 ksi [620 MPa]).	A 732/A 732M	3Q, 4A, 4Q, 5N
4	Low-alloy steel (annealed, normalized, or normalized and tempered. Tensile strength less than 85 ksi [585 MPa]).	A 148/A 148M	80-50
		A 217/A 217M	WC1, WC4, WC5, WC6, WC9
		A 352/A 352M	LC1, LC2, LC3, LC4
		A 356/A 356M	2, 5, 6, 8
		A 389/A 389M	C23, C24
		A 487/A 487M	11A, 12A, 16A
5	Low-alloy steel (annealed, normalized, or normalized and tempered. Tensile strength equal to or greater than 85 ksi [585 MPa]).	A 757/A 757M	B2N, B3N, B4N
		A 148/A 148M	90-60, 105-85
		A 217/A 217M	C5, C12, C12A, WC11
		A 356/A 356M	9, 10, C12
		A 487/A 487M	1A, 1C, 2A, 2C, 4A, 4C, 6A, 8A, 9A, 9C, 10A, 13A
		A 732/A 732M	6N, 15A
6	Low-alloy steel (quenched and tempered)	A 757/A 757M	D1N1, D1N2, D1N3, E2N1, E2N2, E2N3
		A 148/A 148M	90-60, 105-85, 115-95, 130-115, 135-125, 150-135, 160-145, 165-150, 165-150L, 210-180, 210-180L, 260-210, 260-210L
		A 352/A 352M	LC2-1, LC1, LC2, LC3, LC4, LC9
		A 487/A 487M	1B, 1C, 2B, 2C, 4B, 4C, 4D, 4E, 6B, 7A, 8B, 8C, 9A, 9B, 9C, 9D, 9E, 10B, 11B, 12B, 13B, 14A
		A 732/A 732M	7Q, 8Q, 9Q, 10Q, 11Q, 12Q, 13Q, 14Q
		A 757/A 757M	B2Q, B3Q, B4Q, C1Q, D1Q1, D1Q2, D1Q3, E1Q, E2Q1, E2Q2, E2Q3
7	Ferritic stainless steel	A 743/A 743M	CB-30, CC-50
8	Martensitic stainless steel	A 217/A 217M	CA-15
		A 352/A 352M	CA6NM
		A 356/A 356M	CA6NM
		A 487/A 487M	CA15-A, CA15-B, CA15-C, CA15-D, CA15M-A, CA6NM-A, CA6NM-B
		A 743/A 743M	CA-15, CA-15M, CA6NM, CA-40, CA6N, CB6
		A 757/A 757M	E3N

TABLE 1 *Continued*

Category Number	Material Description	ASTM Specification	Grades
9	Low-carbon austenitic stainless steel (carbon equal to or less than 0.03 %)	A 351/A 351M	CF-3, CF-3A, CF-3M, CF-3MA, CF-3MN, CK-3MCUN, CG3M, CN3MN
		A 743/A 743M	CF-3, CF-3M, CF-3MN, CK-3MCUN, CN-3M, CG3M, CN3MN
		A 744/A 744M	CF-3, CF-3M, CK-3MCUN, CG3M, CN3MN
10	Unstabilized austenitic stainless steel (carbon greater than 0.03 %)	A 351/A 351M	CE-8MN, CF-8, CF-8A, CF-8M, CF-10, CF-10M, CG-8M, CH-8, CH-10, CH-20, CG6MMN, CF10S1MNN, CE20N
		A 447/A 447M	Type I
		A 743/A 743M	CF-8, CG-12, CF-20, CF-8M, CF-16F, CF10SMNN, CH-20, CG-8M, CE-30, CG6MMN, CH10, CF16Fa
		A 744/A 744M	CF-8, CF-8M, CG-8M
11	Stabilized austenitic stainless steel	A 351/A 351M	CF-8C, CF-10MC, CK-20, HK-30, HK-40, HT-30, CN-7M, CT-15C
		A 447/A 447M	Type II
		A 743/A 743M	CF-8C, CN-7M, CN-7MS, CK-20
		A 744/A 744M	CF-8C, CN-7M, CN-7MS
12	Duplex (austenitic-ferritic) stainless steel	A 351/A 351M	CD3MWCuN, CD-4MCU
		A 872/A 872M	J93183, J93550
		A 890/A 890M	1A, 1B, 2A, 3A, 4A, 5A, 6A
		A 995/A 995M	1B, 2A, 3A, 4A, 5A, 6A
13	Precipitation-hardened austenitic stainless steel	A 747/A 747M	CB7CU-1, CB7CU-2
14	Nickel-base alloys	A 494/A 494M	CW-12MW, CY-40 Class 1, CY-40 Class 2, CZ-100, M-35-1, M-35-2, M-30C, N-12MV, N-7M, CW-6M, CW-2M, CW-6MC, CX-2MW, CU5MCUC
		A 990/A 990M	CW2M

3. Terminology

3.1 *Definitions*— Definitions of terms relating to welding shall be in agreement with the definitions of the American Welding Society, ANSI/AWS A3.0.

4. Weld Orientation

4.1 *Orientation*— The orientation of welds with respect to horizontal and vertical planes of reference are classified into four positions, namely, flat, horizontal, vertical, and overhead as shown in Fig. 4. Test material shall be oriented as shown in Fig. 4; however, an angular deviation of $\pm 15^\circ$ from the specified horizontal and vertical planes is permitted during welding.

4.2 *Flat Position* (Fig. 4(a))—This position covers plate in a horizontal plane with the weld metal deposited from above, or pipe or a cylindrical casting with its axis horizontal and rolled during welding so that the weld metal is deposited from above.

4.3 *Horizontal Position* (Fig. 4(b))—This position covers plate in a vertical plane with the axis of the weld horizontal, or pipe or a cylindrical casting with its axis vertical and the axis of the weld horizontal.

4.4 *Vertical Position* (Fig. 4(c))—In this position the plate is in a vertical plane with the axis of the weld vertical.

4.5 *Overhead Position* (Fig. 4(d))—In this position the plate is in a horizontal plane with the weld metal deposited from underneath.

4.6 *Horizontal Fixed Position* (Fig. 4(e))—In this position the pipe or cylindrical casting has its axis horizontal and the welding groove in a vertical plane. Welding shall be done

without rotating the pipe or casting so that the weld metal is deposited from the flat, vertical, and overhead position.

4.7 *Qualification*— Qualification in the horizontal, vertical, or overhead position shall qualify also for the flat position. Qualification in the horizontal fixed position, or in the horizontal and vertical and overhead positions, shall qualify for all positions (Fig. 4(f)).

5. Preparation of Test Plate

5.1 Procedure qualification testing shall be performed on cast or wrought material having the same category number as the casting being welded. Test material shall be subjected to the same heat-treatment before and after welding as will be applied to the casting. If the castings are not to be postweld heat-treated, then the test material is not to be postweld heat-treated. Test plate material for performance qualification testing is covered in 12.2.

5.2 The dimensions of the test plate shall be such as to provide the required number of test specimens.

5.3 The test joint shall be welded using the type of welding groove proposed in the welding procedure. The dimensions of the welding groove are not essential variables of the welding procedure.

5.4 The thickness of the test plate shall depend on the range of thickness to be qualified as shown in Table 2 and Table 3.

5.5 The joint preparation shown in Fig. 5 shall qualify the supplier for all welding on steel castings.

5.6 Where pipe or a cylindrical casting is used for qualification, it is recommended that a minimum nominal diameter of 5 in. [125 mm] and a minimum thickness of $\frac{3}{8}$ in. [10 mm] be used.

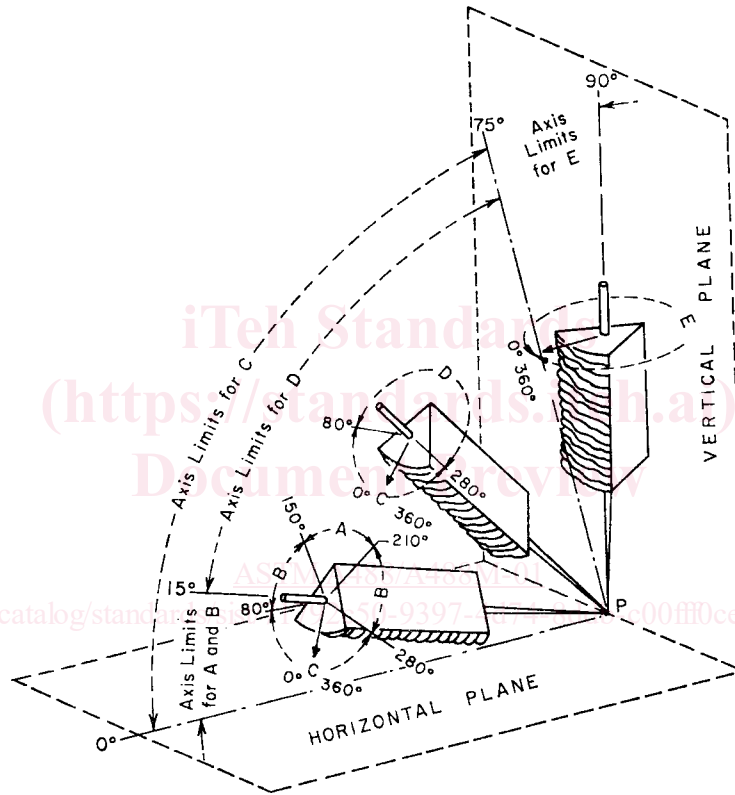
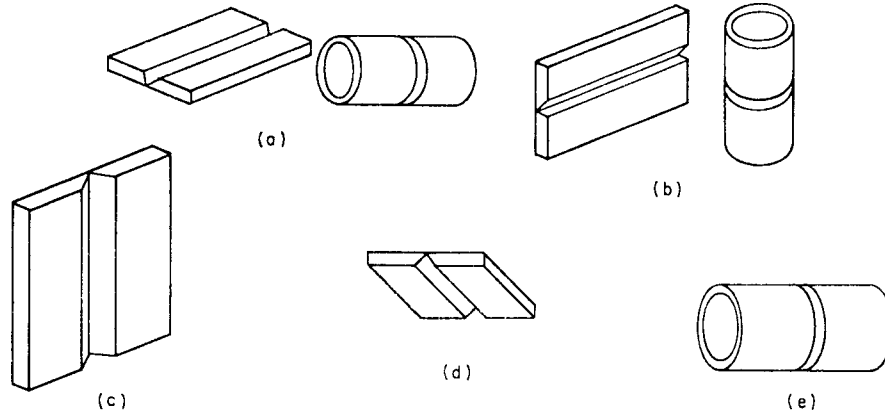

Tabulation of Positions of Groove Welds

Position	Diagram Reference	Inclination of Axis, °	Rotation of Face, °
Flat	A	0 to 15	150 to 210
Horizontal	B	0 to 15	80 to 150 210 to 280
Overhead	C	0 to 75	0 to 80 280 to 360
Vertical	D	15 to 75	80 to 280
	E	75 to 90	0 to 360

NOTE 1—(a) Flat Position; (b) Horizontal Position; (c) Vertical Position; (d) Overhead Position; (e) Horizontal Fixed Position; (f) Positions of Groove Welds

FIG. 4 Orientation of Welds