

---

# International Standard



# 8269

---

INTERNATIONAL ORGANIZATION FOR STANDARDIZATION • МЕЖДУНАРОДНАЯ ОРГАНИЗАЦИЯ ПО СТАНДАРТИЗАЦИИ • ORGANISATION INTERNATIONALE DE NORMALISATION

---

## Doorsets — Static loading test

*Blocs-portes — Essai de charge statique*

First edition — 1985-07-01

**iTeh STANDARD PREVIEW**  
**(standards.iteh.ai)**

[ISO 8269:1985](https://standards.iteh.ai/catalog/standards/sist/6ffcc466-25d8-486a-ba53-832505c001bd/iso-8269-1985)

<https://standards.iteh.ai/catalog/standards/sist/6ffcc466-25d8-486a-ba53-832505c001bd/iso-8269-1985>

---

UDC 69.028.1 : 620.173

Ref. No. ISO 8269-1985 (E)

**Descriptors** : doors, door frames, tests, static tests, static loads.

## Foreword

ISO (the International Organization for Standardization) is a worldwide federation of national standards bodies (ISO member bodies). The work of preparing International Standards is normally carried out through ISO technical committees. Each member body interested in a subject for which a technical committee has been established has the right to be represented on that committee. International organizations, governmental and non-governmental, in liaison with ISO, also take part in the work.

Draft International Standards adopted by the technical committees are circulated to the member bodies for approval before their acceptance as International Standards by the ISO Council. They are approved in accordance with ISO procedures requiring at least 75 % approval by the member bodies voting.

International Standard ISO 8269 was prepared by Technical Committee ISO/TC 162, *Doors and windows*.

**ITEH STANDARD PREVIEW**  
(standards.iteh.ai)

[ISO 8269:1985](https://standards.iteh.ai/catalog/standards/sist/6ffcc466-25d8-486a-ba53-832505c001bd/iso-8269-1985)

<https://standards.iteh.ai/catalog/standards/sist/6ffcc466-25d8-486a-ba53-832505c001bd/iso-8269-1985>

# Doorsets — Static loading test

## 1 Scope and field of application

This International Standard specifies a method of testing the behaviour of doorsets under static loading.

It applies to doorsets with one pivoting leaf, without fixed parts other than the door frame itself, and for which special requirements against static loading apply, for example requirements relating to burglar resistance.

## 2 Reference

ISO 1804, *Doors — Terminology*.

## 3 Definitions

For the purposes of this International Standard, the definitions given in ISO 1804 apply.

## 4 Principle

Application, by means of a steel plate or shackle, of perpendicular and parallel compressive forces on the face of the door leaf in the opening direction, or on the door frame, in order to unbolt the door or to obtain a possibility of passage.

## 5 Apparatus

The apparatus comprises the following.

**5.1 Adjustable test rig**, in which doorsets of various sizes can be mounted in a manner similar to their installation in practice; the rig shall be sufficiently rigid to ensure that any deformations that occur in the rig during testing will have a negligible effect on the test result.

## 5.2 Jacks.

**5.3 Rigid rectangular steel plates**, of length 100 mm and width "d" at least equal to the thickness of the door leaf. See figure 1.

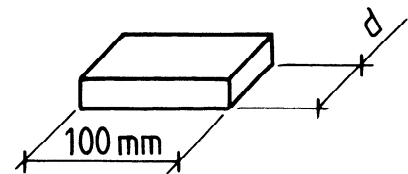

Figure 1 — Steel plate

**5.4 Rigid steel shackle**, used as a bridge over the lock or bolt. See figure 2.

**5.5 Several displacement gauges.**

**5.6 Two timers**, to time the test and also to time the duration of any interruptions due to technical incidents.

## 6 Procedure

**6.1** Secure the door frame firmly to the test rig by means of an adjustable fixing device with a block if necessary. The rigidity of fixing to the door frame shall be sufficient to ensure that the results are not affected by it.

**6.2** Apply compressive forces as follows:

- a) Force  $F_1$  at the edge of the door leaf in the position, or positions, which seem to be the weakest, using the rectangular plate (5.3) or shackle (5.4) when the plate is not convenient (parallel or perpendicular force). See figure 3.

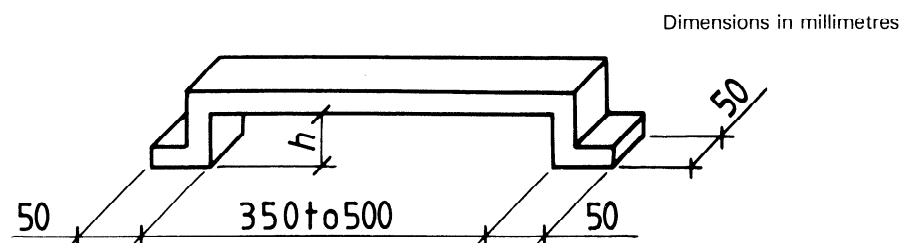

Figure 2 — Steel shackle

- b) Force  $F_2$  on the free corners of the door leaf as shown in figure 4 or, if this is not possible, in the closest areas.
- c) Force  $F_3$  at every hinge level, the geometrical centre of the plate (5.3) being located on one of the axes as shown in figure 5 or, if this is not possible, in the closest areas.
- d) Force  $F_4$  at the lock or bolt level in the closed position, using the plate (5.3) or shackle (5.4), whichever is the more convenient, and taking into consideration, for its position, one of the axes shown in figure 6.

**6.3** Gradually increase each compressive force without shock and without excessive speed in order to reach the maximum force in 1 min. Maintain this force for 1 min. [See figure 3 b).]

**6.4** Note, during the test and after the test, for each point of application:

- the force;
- the maximum deformation;
- the residual deformation;
- displacements;
- final damage.

## 7 Test report

The test report shall include the following information:

- a) detailed information concerning the material, type, dimensions, shape, construction and finish of the door and of the door frame and a description of the hardware used;
- b) the forces  $F_1$ ,  $F_2$ ,  $F_3$  and  $F_4$  and the positions in which they were applied;
- c) damage resulting from the test, together with observations on the nature, position and severity of such damage.

# iTeh STANDARD PREVIEW (standards.iteh.ai)

[ISO 8269:1985](https://standards.iteh.ai/catalog/standards/sist/6ffcc466-25d8-486a-ba53-832505c001bd/iso-8269-1985)

<https://standards.iteh.ai/catalog/standards/sist/6ffcc466-25d8-486a-ba53-832505c001bd/iso-8269-1985>

Dimensions in millimetres

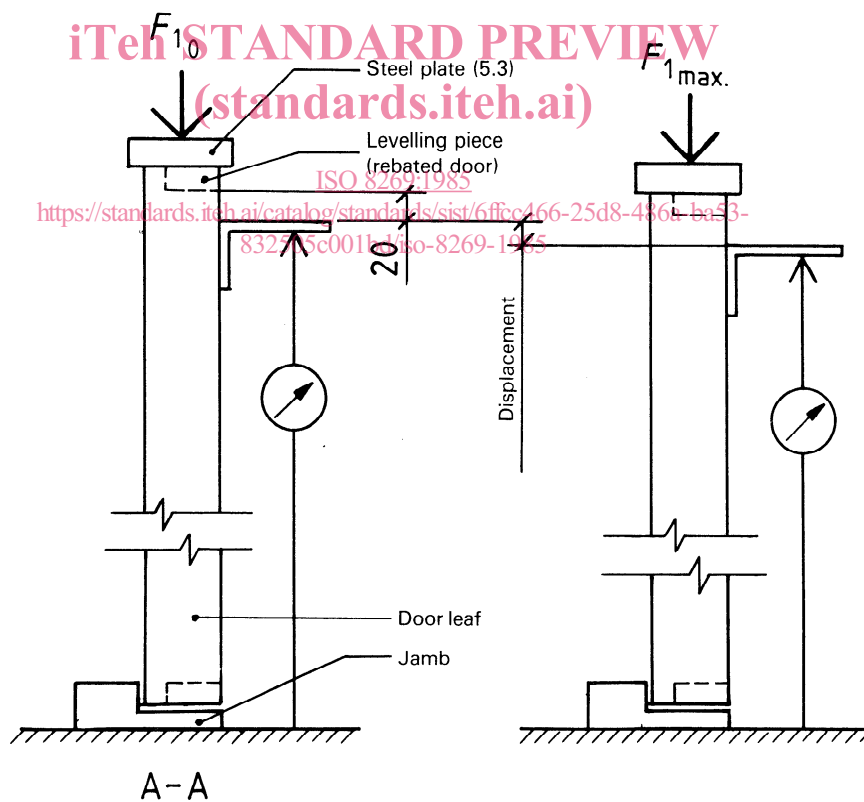
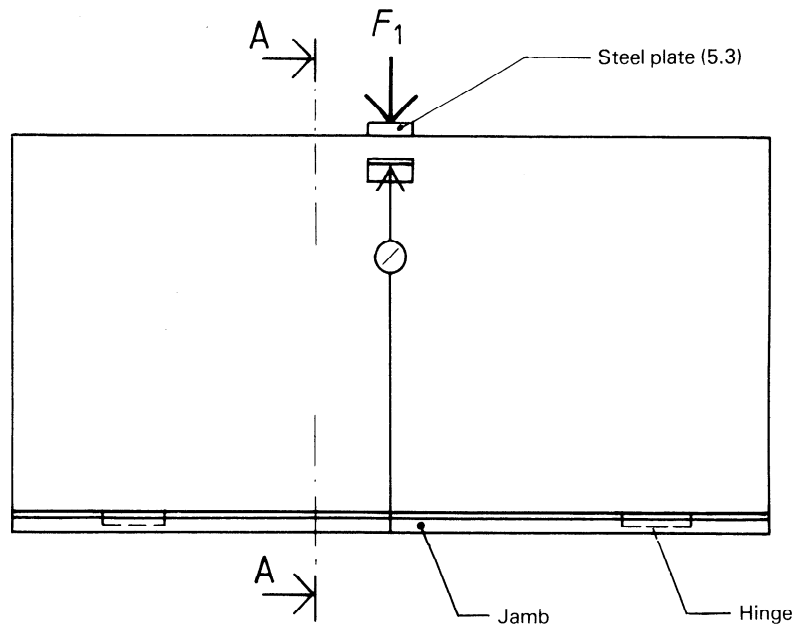

Measurement of displacement

a) before application of the load

b) after application of the load for 1 min

Figure 3 — Testing the edge of the door leaf

Dimensions in millimetres

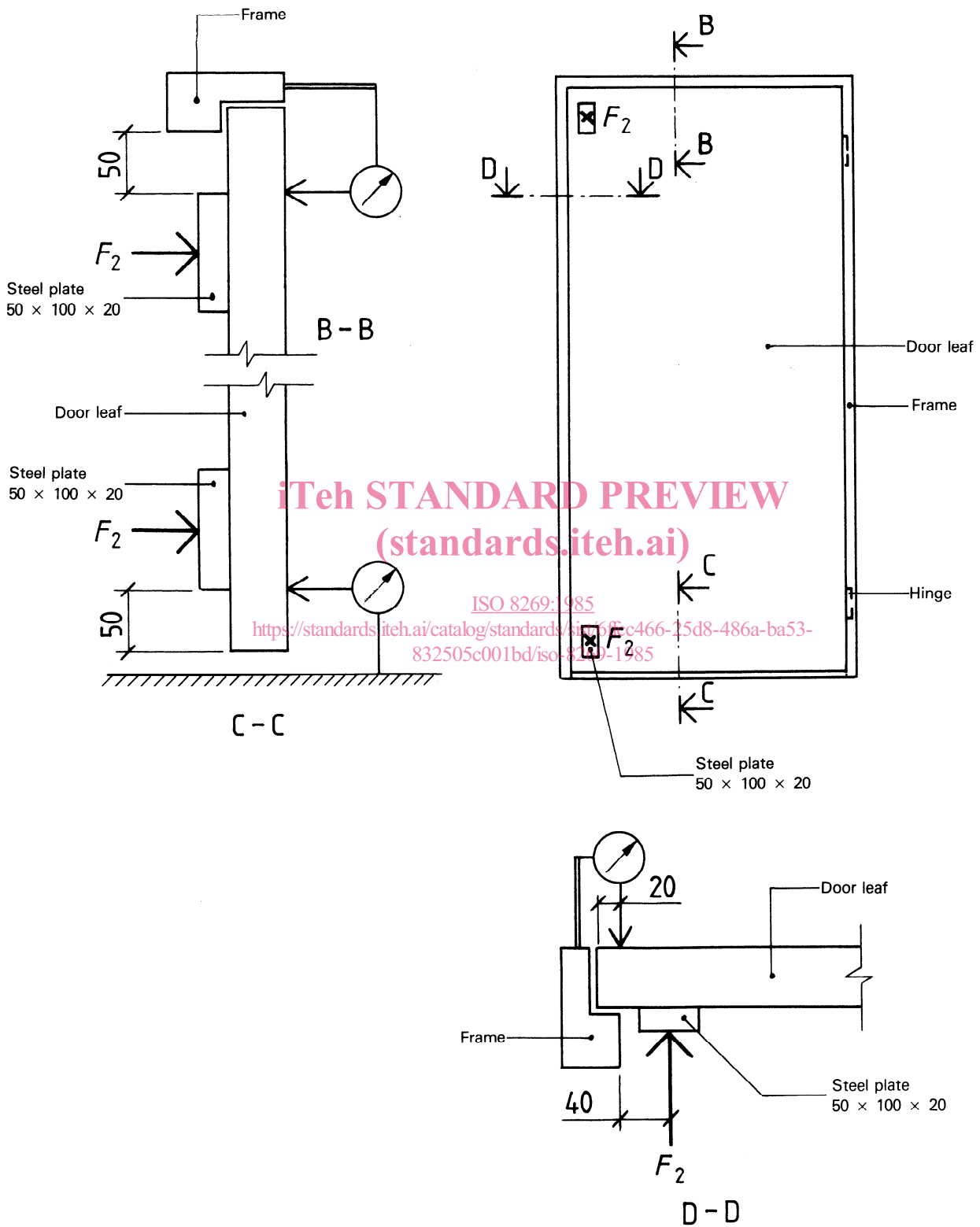

Figure 4 — Testing the free corners of the door leaf

Dimensions in millimetres

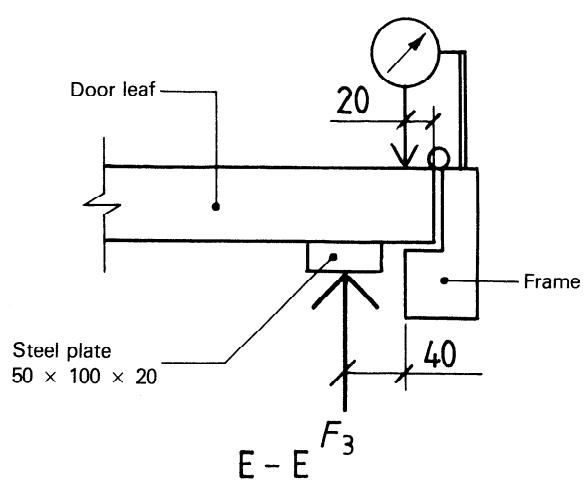
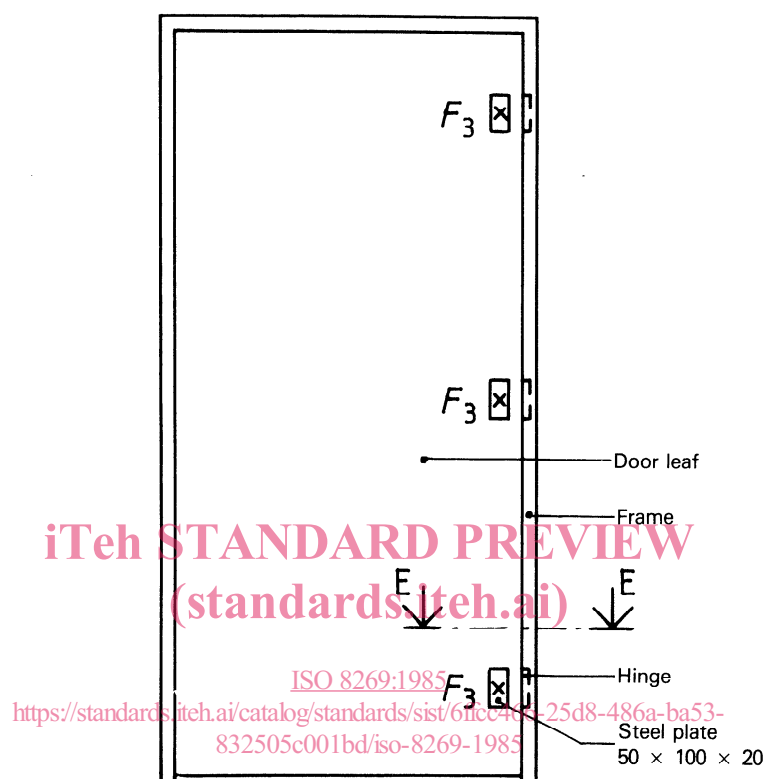

Figure 5 — Testing the hinge side of the door leaf

Dimensions in millimetres

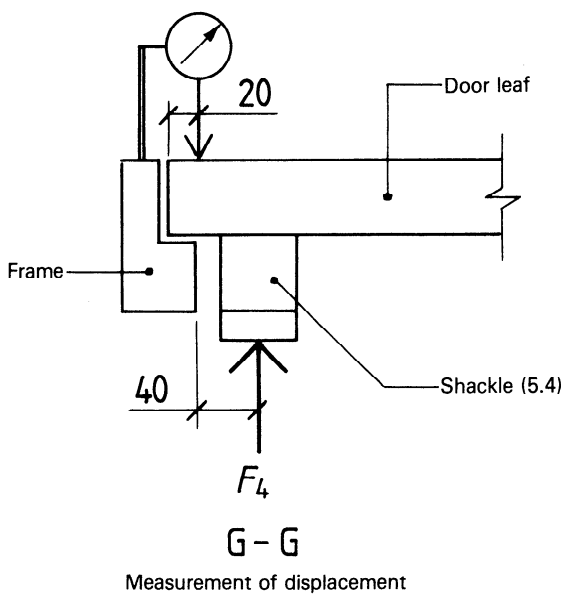
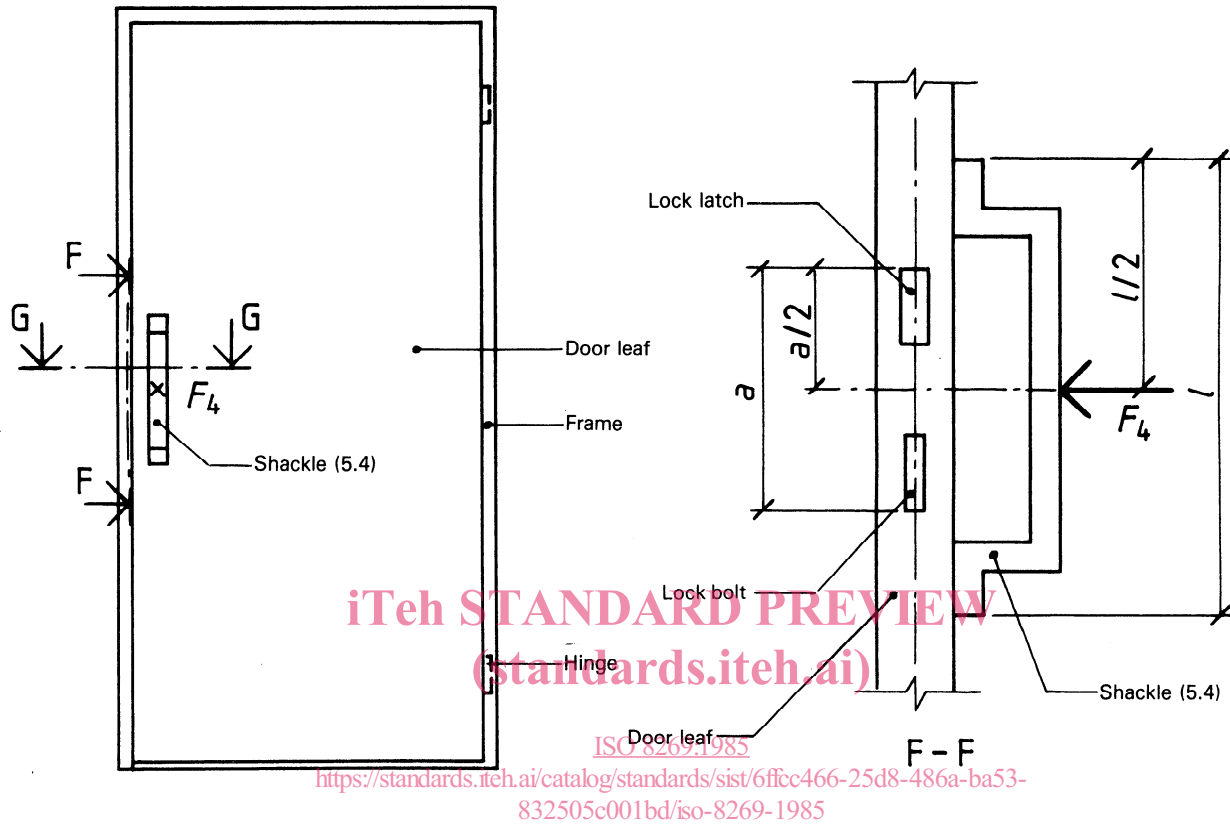

Figure 6 — Testing on lock side