



Standard Specification for Castings, Steel and Alloy, Common Requirements, for General Industrial Use¹

This standard is issued under the fixed designation A 781/A 781M; the number immediately following the designation indicates the year of original adoption or, in the case of revision, the year of last revision. A number in parentheses indicates the year of last reapproval. A superscript epsilon (ϵ) indicates an editorial change since the last revision or reapproval.

1. Scope

1.1 This specification covers a group of requirements that are mandatory requirements of the following steel casting specifications issued by ASTM. If the product specification specifies different requirements, the product specification shall prevail.

ASTM Designation	Title of Specification
A 27/A 27M	Steel Castings, Carbon, for General Application
A 128/A 128M	Steel Castings, Austenitic Manganese
A 148/A 148M	Steel Castings, High-Strength, for Structural Purposes
A 297/A 297M	Steel Castings, Iron Chromium and Iron-Chromium-Nickel, Heat Resistant for General Application
A 447/A 447M	Steel Castings, Chromium-Nickel-Iron Alloy (25-12 Class), for High-Temperature Service
A 486/A 486M	Steel Castings, for Highway Bridges
A 494/A 494M	Castings, Nickel and Nickel Alloy
A 560/A 560M	Castings, Chromium-Nickel Alloy
A 743/A 743M	Castings, Iron-Chromium, Iron-Chromium-Nickel, Corrosion Resistant, for General Application
A 744/A 744M	Castings, Iron-Chromium-Nickel, Corrosion Resistant, for Severe Service
A 747/A 747M	Steel Castings, Stainless, Precipitation Hardening
A 890/A 890M	Castings, Iron-Chromium-Nickel-Molybdenum Corrosion-Resistant, Duplex (Austenitic/Ferritic) for General Application
A 915/A 915M	Steel Castings, Carbon and Alloy Chemical
A 915/A 915M	Steel Castings, Carbon and Alloy, Chemical Requirements Similar to Standard Wrought Grades

1.2 This specification also covers a group of supplementary requirements that may be applied to the above specifications as indicated therein. These are provided for use when additional testing or inspection is desired and apply only when specified individually by the purchaser in the order.

1.3 The requirements of the individual material specification, and this general specification shall prevail in the sequence named.

1.4 The values stated in either inch-pound units or SI units are to be regarded separately as standard. Within the text, the SI units are shown in brackets. The values stated in each system are not exact equivalents; therefore, each system must be used independently of the other. Combining values from the two systems may result in nonconformance with the specification. Inch-pound units are applicable for material ordered to Specification A 781 and SI units for material ordered to Specification A 781M.

2. Referenced Documents

2.1 ASTM Standards:

A 27/A27M Specification for Steel Castings, Carbon, for General Application²

A 128/A128M Specification for Steel Castings, Austenitic Manganese²

A 148/A148M Specification for Steel Castings, High Strength, for Structural Purposes²

A 297/A297M Specification for Steel Castings, Iron-Chromium and Iron-Chromium-Nickel, Heat Resistant, for General Application²

¹ This specification is under the jurisdiction of ASTM Committee A01 on Steel, Stainless Steel, and Related Alloys and is the direct responsibility of Subcommittee A01.18 on Castings.

Current edition approved Sept-Oct. 10, 2000; 2001. Published October 2000; December 2001. Originally published as A 781 – 80. Last previous edition A 781/A 781M – 99a. A 781/A 781M – 00.

² Annual Book of ASTM Standards, Vol 01.02.

- A 370 Test Methods and Definitions for Mechanical Testing of Steel Products³
- ~~A 447/A 447M Specification for Steel Castings, Chromium-Nickel-Iron Alloy (25-12 Class), for High-Temperature Service²~~
- ~~380 Practice for Cleaning, Descaling, and Passivation of Stainless Steel Parts, Equipment, and Systems³~~
- ~~A 447/A 447M Specification for Steel Castings, Chromium-Nickel-Iron Alloy (25-12 Class), for High-Temperature Service²~~
- ~~A 486/A 486M Specification for Steel Castings for Highway Bridges²~~
- A 488/A 488M Practice for Steel Castings, Welding, Qualifications of Procedures and Personnel²
- A 494/A 494M Specification for Castings, Nickel and Nickel Alloy²
- A 560/A 560M Specification for Castings, Chromium-Nickel Alloy²
- A 609/A 609M Practice for Castings, Carbon, Low-Alloy, and Martensitic Stainless Steel, Ultrasonic Examination Thereof²
- A 743/A 743M Specification for Castings, Iron-Chromium, Iron-Chromium-Nickel, Corrosion-Resistant, for General Application²
- A 744/A 744M Specification for Castings, Iron-Chromium-Nickel, Corrosion Resistant, for Severe Service²
- A 747/A 747M Specification for Steel Castings, Stainless, Precipitation Hardening²
- A 751 Test Methods, Practices, and Terminology for Chemical Analysis of Steel Products³
- A 800/A 800M Practice for Steel Castings, Austenitic Alloy, Estimating Ferrite Content Thereof²
- A 802/A 802M Practice for Steel Castings, Surface Acceptance Standards, Visual Examination²
- A 890/A 890M Specification for Castings, Iron-Chromium-Nickel-Molybdenum Corrosion-Resistant, Duplex (Austenitic/Ferritic) for General Application²
- A 915/A 915M Specification for Steel Castings, Carbon and Alloy, Chemical Requirements Similar to Standard Wrought Grades²
- ~~A 919 Terminology Relating to Heat Treatment of Metals²~~ Terminology Relating to Heat Treatment of Metals⁴
- ~~A 967 Specification for Chemical Passivation Treatments for Stainless Steel Parts³~~
- E 94 Guide for Radiographic ~~Testing~~ Examination⁵
- E 125 Reference Photographs for Magnetic Particle Indications on Ferrous Castings⁵
- E 165 Test Method for Liquid Penetrant Examination⁵
- E 186 Reference Radiographs for Heavy-Walled (2 to 4½-in. (51 to 114-mm)) Steel Castings⁵
- E 280 Reference Radiographs for Heavy-Walled (4½ to 12-in. (114 to 305-mm)) Steel Castings⁵
- E 340 Test Method for Macroetching Metals and Alloys
- E 353 Test Methods for Chemical Analysis of Stainless, Heat-Resisting, Maraging, and Other Similar Chromium-Nickel-Iron Alloys⁶
- E 354 Test Methods for Chemical Analysis of High-Temperature, Electrical, Magnetic, and Other Similar Iron, Nickel, and Cobalt Alloys⁶
- E 446 Reference Radiographs for Steel Castings Up to 2 in. (51 mm) in Thickness⁵
- E 709 Guide for Magnetic Particle Examination⁵

3. Terminology

3.1 Definitions:

3.1.1 The definitions in Test Methods and Definitions A 370, Test Methods, Practices, and Terminology A 751, and Terminology A 919 are applicable to this specification and those listed in 1.1.

4. Materials and Manufacture

4.1 *Melting Process*—The steel shall be made by open-hearth or electric furnace process with or without separate refining such as argon-oxygen-decarburization (AOD) unless otherwise specified in the individual specification.

5. Chemical Composition

5.1 *Chemical Analysis*—Chemical analysis of materials covered by this specification shall be in accordance with Test Methods, Practices, and Terminology A 751.

5.2 *Heat Analysis*—An analysis of each heat shall be made by the manufacturer to determine the percentages of the elements specified in the individual specification for the grade being poured. The analysis shall be made from a test sample preferably taken during the pouring of the heat. When drillings are used, they shall be taken not less than ¼ in. [6.4 mm] beneath the surface. The chemical composition thus determined shall conform to the requirements in the individual specification for the grade being poured.

5.3 *Product Analysis*—A product analysis may be made by the purchaser from material representing each heat, lot, or casting. The analysis shall be made on representative material. Samples for carbon analysis of carbon and alloy steel shall be taken no

³ Annual Book of ASTM Standards, Vol 01.03.

⁴ Discontinued. See 1999 Annual Book of ASTM Standards, Vol 03.03., Vol 01.01.

⁵ Annual Book of ASTM Standards, Vol 03.05., Vol 03.03.

⁶ Information on the relationship of mechanical properties determined on test coupons obtained as specified in 6.2 with those obtained from the casting may be found in "The Steel Casting Handbook," Fifth Edition, Steel Founders' Society of America, pp. 15–35 through 15–43, 1980.

⁶ Annual Book of ASTM Standards, Vol 03.05.

closer than ¼ in. to a cast surface, except that castings too thin for this shall be analyzed on representative material. The chemical composition thus determined shall meet the requirements specified in the applicable specification for the grade involved, or shall be subject to rejection by the purchaser, except that the chemical composition determined for carbon and low alloy steel castings may vary from the specified limits by the amounts shown in Table 1. The product analysis tolerances of Table 1 are not applicable as acceptance criteria for heat analysis by the casting manufacturer. When comparing product and heat analysis for other than carbon and low alloy steels, the reproducibility Data $R_{2,}$ in Test Methods E 353 or E 354, as applicable, shall be taken into consideration.

5.4 *Unspecified Elements*—When chemical analysis for elements not specified for the grade ordered is desired, Supplementary Requirement S13 may be specified.

5.4.1 Grade substitution, for stainless steel or nickel base alloy castings, is not permitted. Grade substitution occurs when the material supplied:

- 1-(1) contains an element, other than nitrogen, that is not specified in the ordered grade; and,
- 2-(2) the amount of that element equals or exceeds the minimum requirement for the element in another grade for which it is specified.

For this requirement, a grade is defined as an alloy described individually in a table of chemical requirements within any specification listed within the scope of A 781/A 781M.

6. Tensile Requirements

6.1 The individual product specifications vary as to whether tension tests are required; for this reason, and to determine specific test requirements, the individual product specification should be reviewed.

6.2 Unless otherwise specified by the purchaser, when mechanical properties are required by the product specification, test coupons may be cast integrally with the castings, or as separate blocks, in accordance with Fig. 1, Fig. 2, or Fig. 3 except when

TABLE 1 Product Analysis Tolerances

Element	Range, % ^A	Tolerances ^{B, C} Over Maximum or Under Minimum Limit, %
C	up to 0.65	$0.03 \times \% C_L + 0.02$
	above 0.65	0.04
Mn	up to 1	$0.08 \times \% Mn_L + 0.01$
	above 1	0.09
Si	up to 0.60	$0.22 \times \% Si_L - 0.01$
	above 0.60	0.15
P	all	$0.13 \times \% P_L + 0.005$
S	all	$0.36 \times \% S_L + 0.001$
Ni	up to 2	$0.10 \times \% Ni_L + 0.03$
	above 2	0.25
Cr	up to 2	$0.07 \times \% Cr_L + 0.04$
	above 2	0.18
Mo	up to 0.6	$0.04 \times \% Mo_L + 0.03$
	above 0.6	0.06
V	up to 0.25	$0.23 \times \% V_L + 0.004$
	above 0.25	0.06
W	up to 0.10	$0.08 \times \% W_L + 0.02$
	above 0.10	0.02
Cu	up to 0.15	$0.18 \times \% Cu_L + 0.02$
	above 0.15	0.05
Al	up to 0.10	$0.08 \times \% Al_L + 0.02$
	above 0.10	0.03

^A The range denotes the composition limits up to which tolerances are computed by the equation, and above which the tolerances are given by a constant.

^B The subscript $_L$ for the elements in each equation indicates that the limits of the element specified by the applicable specification are to be inserted into the equation to calculate the tolerance for the upper limit and the lower limit (if applicable), respectively. Examples of computing tolerances are presented in footnote C.

^C To illustrate the computation of the tolerance, consider the manganese maximum of 0.70 for an 0.30 carbon grade 65–35 in Specification A 27. The maximum permissible deviation is $(0.08 \times 0.70 + 0.01) = 0.066$. Therefore, the highest acceptable product analysis is 0.766. Similarly, for an 0.20 carbon grade 70–40 in Specification A 27, the maximum manganese content is 1.40; thus, the highest acceptable product analysis is $(1.40 + 0.09) = 1.49$.

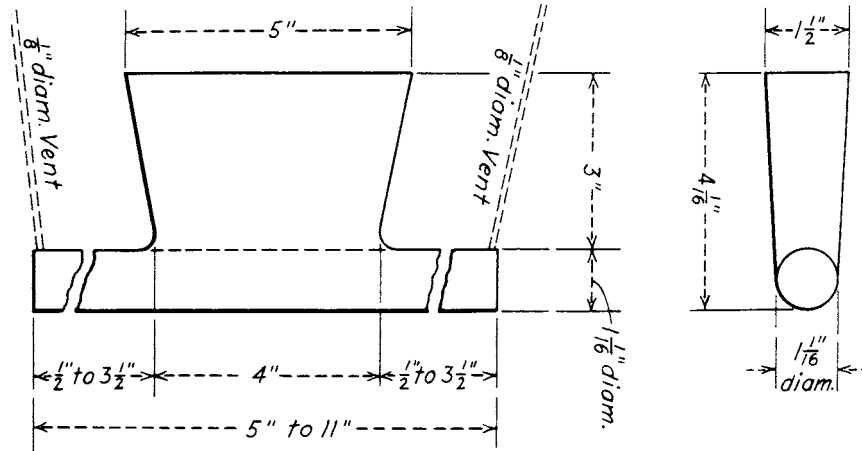

Metric Equivalents

in.	[mm]	in.	[mm]
1/8	[3.2]	3 1/2	[88.9]
1/2	[12.7]	4	[101.6]
1 1/16	[27.0]	4 1/16	[103.2]
1 1/2	[38.1]	5	[127.0]
3	[76.2]	11	[279.4]

NOTE—Pour through head; cover molten head with powdered charcoal, coke dust, etc., immediately after pouring, in order to keep head fluid as long as possible.

FIG. 2 Test Block for Tension Test Specimen

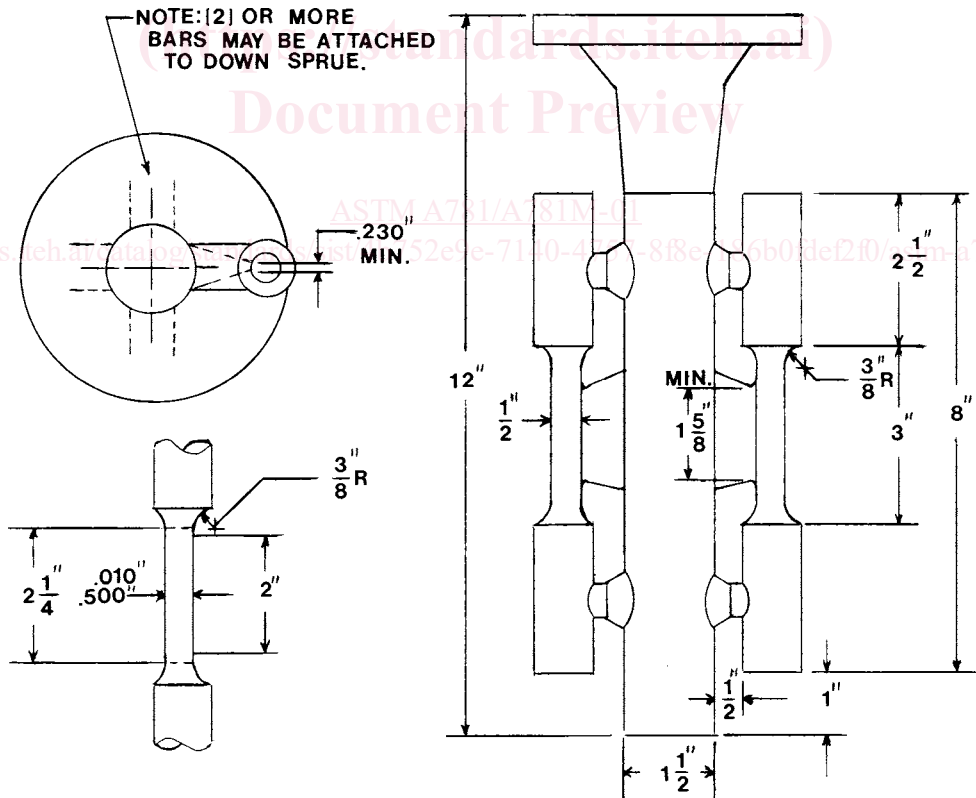

NOTE—Coupons produced in this manner are suitable for austenitic alloys only. The mold may be preheated for pouring to produce a sound coupon.

FIG. 3 Cast-To-Shape Test Coupon for Tension Specimen

purchaser before manufacture is started. If the pattern is supplied by the purchaser, the dimensions of the casting shall be as predicated by the pattern.

8. Quality

8.1 The surface of the casting shall be free of adhering sand, scale, cracks, and hot tears as determined by visual examination. Other surface discontinuities shall meet the visual acceptance standards specified in the order. Practice A 802/A 802M or other visual standards may be used to define acceptable surface discontinuities and finish. Unacceptable visual surface discontinuities shall be removed and their removal verified by visual examination of the resultant cavities.

8.2 When additional inspection is desired, Supplementary Requirements S1, S2, S3, S4, or S5 may be specified.

9. Repair

9.1 Repair by welding shall be in accordance with the requirements of the individual specification using procedures and welders qualified in accordance with Practice A 488/~~A488M~~/A 488M.

10. Inspection

10.1 The manufacturer shall afford the purchaser's inspector all reasonable facilities necessary to satisfy that the material is being produced and furnished in accordance with the applicable specification. Foundry inspection by the purchaser shall not interfere unnecessarily with the manufacturer's operations. All tests and inspections, with the exception of product analysis (5.3), shall be made at the place of manufacture unless otherwise agreed.

11. Rejection

11.1 Subsequent to acceptance at the manufacturer's works, material which is found to be unacceptable as determined by requirements specified in the order may be rejected by the purchaser. The manufacturer should be notified of such rejection. If the manufacturer is dissatisfied with the results of any tests performed by the purchaser, he may make claim for a rehearing.

12. Keywords

12.1 castings; common requirements; steel and alloy

SUPPLEMENTARY REQUIREMENTS

Supplementary requirements shall be applied only when specified by the purchaser. Details of the supplementary requirements shall be agreed upon by the manufacturer and purchaser. The specified tests shall be performed by the manufacturer prior to shipment of the castings.

S1. Magnetic Particle Examination

S1.1 Castings shall be examined for surface and near surface discontinuities by magnetic particle examination. The examination shall be in accordance with Guide E 709. Extent of examination and the basis for acceptance shall be agreed upon between the manufacturer and purchaser.

S2. Radiographic Examination

S2.1 Castings shall be examined for internal defects by means of X rays or gamma rays. The procedure shall be in accordance with Guide E 94, and types and degrees of discontinuities considered shall be judged by Reference Radiographs E 446, E 186, or E 280. Extent of examination and basis for acceptance shall be agreed upon between the manufacturer and purchaser.

S3. Liquid Penetrant Examination

S3.1 Castings shall be examined for surface discontinuities by means of liquid penetrant examination. The examination shall be in accordance with Test Method E 165. Areas to be inspected, methods and types of liquid penetrants to be used, developing procedure, and basis for acceptance shall be agreed upon between the manufacturer and purchaser.

S4. Ultrasonic Examination

S4.1 Castings shall be examined for internal defects by means of ultrasonic examination. The examination procedure shall be in accordance with Practice A 609/A 609M. Extent of examination, methods of testing, and basis for acceptance shall be agreed upon between the manufacturer and purchaser.

S5. Examination of Weld Preparation

S5.1 Magnetic particle or liquid penetrant examination of cavities prepared for welding shall be performed to verify removal of those discontinuities found unacceptable by the examination method specified for the casting. Unless other degrees of shrinkage or types of discontinuities found in the cavities are specified, Type II, Internal Shrinkage, of Reference Photographs E 125, of Degree 2 in sections up to 2 in. (~~50.8 mm~~)[50.8 mm] thick and of Degree 3 in sections over 2 in. thick shall be acceptable.

S6. Certification

S6.1 The manufacturer's certification shall be furnished to the purchaser stating that the material was manufactured, sampled,