

INTERNATIONAL STANDARD

**Packaging of components for automatic handling –
Part 3-2: Packaging of surface mount components on continuous tapes –
Type VI – Blister carrier tapes of 4 mm width**

IEC 60286-3-2:2009

<https://standards.iec.ch/cats/catalog/standards/sls/3/8b3ac3-390c-41d5-99aa-3414edb23efb/iec-60286-3-2-2009>



THIS PUBLICATION IS COPYRIGHT PROTECTED

Copyright © 2009 IEC, Geneva, Switzerland

All rights reserved. Unless otherwise specified, no part of this publication may be reproduced or utilized in any form or by any means, electronic or mechanical, including photocopying and microfilm, without permission in writing from either IEC or IEC's member National Committee in the country of the requester.

If you have any questions about IEC copyright or have an enquiry about obtaining additional rights to this publication, please contact the address below or your local IEC member National Committee for further information.

IEC Central Office
3, rue de Varembe
CH-1211 Geneva 20
Switzerland
Email: inmail@iec.ch
Web: www.iec.ch

About the IEC

The International Electrotechnical Commission (IEC) is the leading global organization that prepares and publishes International Standards for all electrical, electronic and related technologies.

About IEC publications

The technical content of IEC publications is kept under constant review by the IEC. Please make sure that you have the latest edition, a corrigenda or an amendment might have been published.

- Catalogue of IEC publications: www.iec.ch/searchpub

The IEC on-line Catalogue enables you to search by a variety of criteria (reference number, text, technical committee,...). It also gives information on projects, withdrawn and replaced publications.

- IEC Just Published: www.iec.ch/online_news/justpub

Stay up to date on all new IEC publications. Just Published details twice a month all new publications released. Available on-line and also by email.

- Electropedia: www.electropedia.org

The world's leading online dictionary of electronic and electrical terms containing more than 20 000 terms and definitions in English and French, with equivalent terms in additional languages. Also known as the International Electrotechnical Vocabulary online.

- Customer Service Centre: www.iec.ch/webstore/custserv

If you wish to give us your feedback on this publication or need further assistance, please visit the Customer Service Centre FAQ or contact us:

Email: csc@iec.ch
Tel.: +41 22 919 02 11
Fax: +41 22 919 03 00

INTERNATIONAL STANDARD

**Packaging of components for automatic handling –
Part 3-2: Packaging of surface mount components on continuous tapes –
Type VI – Blister carrier tapes of 4 mm width**

INTERNATIONAL
ELECTROTECHNICAL
COMMISSION

PRICE CODE

K

ICS 31.020; 31.240

ISBN 978-2-88910-092-7

CONTENTS

FOREWORD.....	3
INTRODUCTION.....	5
1 General.....	5
1.1 Scope.....	5
1.2 Normative references	5
2 Tape dimensions	6
3 Polarity and orientation of components in the tape	8
4 Fixing components and additional tape requirements.....	8
4.1 Tape requirements	8
4.2 Peel force of the cover tape.....	9
4.3 Minimum bending radius.....	9
4.4 Break force of the cover tapes.....	9
4.5 Taping material	9
5 Packing	9
5.1 General.....	9
5.2 Reel dimensions.....	9
6 Marking.....	9
Annex A (informative) Dimensions of reel	10
Figure 1 – Type VI carrier tape	6
Figure 2 – Maximum pocket off-set.....	6
Figure 3 – Maximum component tilt, rotation and lateral movement	7
Figure A.1 – Reel.....	10
Table 1 – Constant dimensions of carrier tape	7
Table 2 – Variable dimensions of carrier tape	8
Table A.1 – Dimensions of reel.....	10

INTERNATIONAL ELECTROTECHNICAL COMMISSION

PACKAGING OF COMPONENTS FOR AUTOMATIC HANDLING –**Part 3-2: Packaging of surface mount components on continuous tapes –
Type VI – Blister carrier tapes of 4 mm width**

FOREWORD

- 1) The International Electrotechnical Commission (IEC) is a worldwide organization for standardization comprising all national electrotechnical committees (IEC National Committees). The object of IEC is to promote international co-operation on all questions concerning standardization in the electrical and electronic fields. To this end and in addition to other activities, IEC publishes International Standards, Technical Specifications, Technical Reports, Publicly Available Specifications (PAS) and Guides (hereafter referred to as "IEC Publication(s)"). Their preparation is entrusted to technical committees; any IEC National Committee interested in the subject dealt with may participate in this preparatory work. International, governmental and non-governmental organizations liaising with the IEC also participate in this preparation. IEC collaborates closely with the International Organization for Standardization (ISO) in accordance with conditions determined by agreement between the two organizations.
- 2) The formal decisions or agreements of IEC on technical matters express, as nearly as possible, an international consensus of opinion on the relevant subjects since each technical committee has representation from all interested IEC National Committees.
- 3) IEC Publications have the form of recommendations for international use and are accepted by IEC National Committees in that sense. While all reasonable efforts are made to ensure that the technical content of IEC Publications is accurate, IEC cannot be held responsible for the way in which they are used or for any misinterpretation by any end user.
- 4) In order to promote international uniformity, IEC National Committees undertake to apply IEC Publications transparently to the maximum extent possible in their national and regional publications. Any divergence between any IEC Publication and the corresponding national or regional publication shall be clearly indicated in the latter.
- 5) IEC provides no marking procedure to indicate its approval and cannot be rendered responsible for any equipment declared to be in conformity with an IEC Publication.
- 6) All users should ensure that they have the latest edition of this publication.
- 7) No liability shall attach to IEC or its directors, employees, servants or agents including individual experts and members of its technical committees and IEC National Committees for any personal injury, property damage or other damage of any nature whatsoever, whether direct or indirect, or for costs (including legal fees) and expenses arising out of the publication, use of, or reliance upon, this IEC Publication or any other IEC Publications.
- 8) Attention is drawn to the Normative references cited in this publication. Use of the referenced publications is indispensable for the correct application of this publication.
- 9) Attention is drawn to the possibility that some of the elements of this IEC Publication may be the subject of patent rights. IEC shall not be held responsible for identifying any or all such patent rights.

International Standard IEC 60286-3-2 has been prepared by IEC technical committee 40: Capacitors and resistors for electronic equipment.

The text of this standard is based on the following documents:

FDIS	Report on voting
40/1973/FDIS	40/1982/RVD

Full information on the voting for the approval of this standard can be found in the report on voting indicated in the above table.

IEC 60286-3-2 is to be used in conjunction with IEC 60286-3.

This publication has been drafted in accordance with the ISO/IEC Directives, Part 2.

The list of all parts of the IEC 60286 series, under the general title *Packaging of components for automatic handling*, can be found on the IEC website.

The committee has decided that the contents of this publication will remain unchanged until the maintenance result date indicated on the IEC web site under "<http://webstore.iec.ch>" in the data related to the specific publication. At this date, the publication will be

- reconfirmed,
- withdrawn,
- replaced by a revised edition, or
- amended.

A bilingual version of this publication may be issued at a later date.

Withdawn

iTeh STANDARD PREVIEW
(standards.iteh.ai)

<https://standards.iteh.ai/catalog/standards/sist/5/81/5ac3-390c-41d5-99aa-3414edb23efb/iec-60286-3-2-2009>

PACKAGING OF COMPONENTS FOR AUTOMATIC HANDLING –

Part 3-2: Packaging of surface mount components on continuous tapes – Type VI – Blister carrier tapes of 4 mm width

INTRODUCTION

Tape packaging meets the requirements of automatic component placement machines and also covers the use of tape packing for components for test purpose and other operations.

This International Standard has been developed to introduce a new 4 mm width carrier tape with 1 mm pitch cavities suitable for very small components. This can be used to replace paper tape for processing in clean rooms where particulates have to be controlled.

1 General

1.1 Scope

This part of IEC 60286 is applicable to the tape packing of ultra small surface mount components using plastic blister carrier tape of 4 mm in width which has concave cavities for containing components of 1 mm in pitch of the component compartments (W4P1).

1.2 Normative references

The following referenced documents are indispensable for the application of this document. For dated references, only the edition cited applies. For undated references, the latest edition of the referenced document (including any amendments) applies.

IEC 60286-3:2007, *Packaging of components for automatic handling – Part 3: Packaging of surface mount components on continuous tapes*

2 Tape dimensions

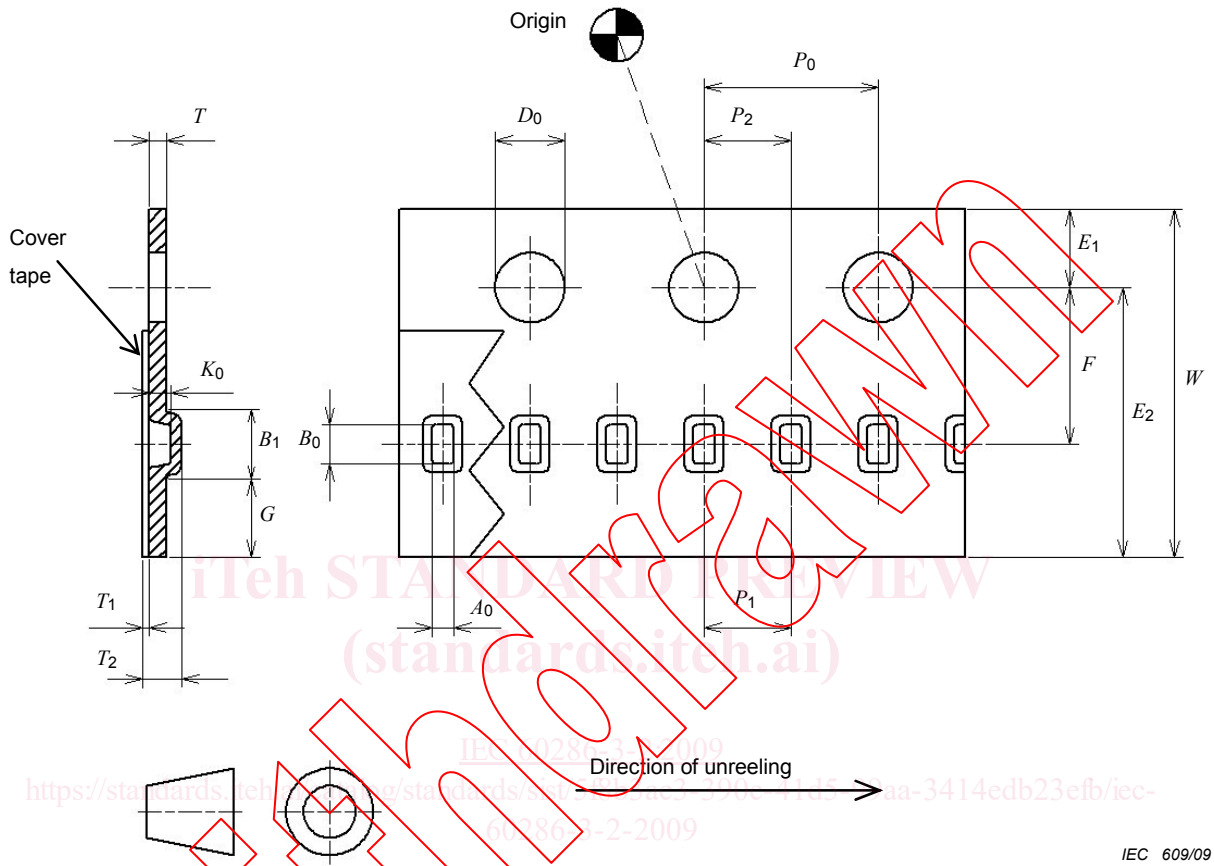

Figure 1 – Type VI carrier tape

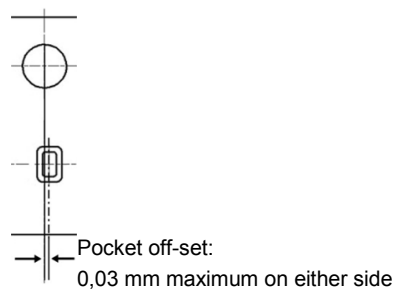

Figure 2 – Maximum pocket off-set

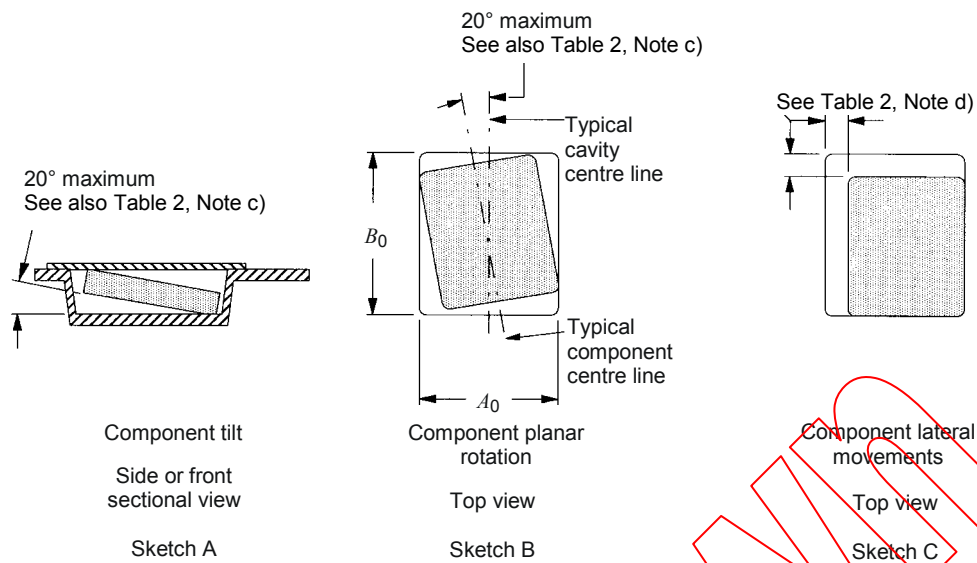

Figure 3 – Maximum component tilt, rotation and lateral movement

Table 1 – Constant dimensions of carrier tape

Tape size mm	D_0 mm	E_1 mm	G_{\min} mm	P_0 mm	T_{\min} mm	T_{\max} mm	$T_1 \max$ mm	Cumulative pitch (over 20 pitches) mm
4	$0,80 \pm 0,04$	$0,90 \pm 0,05$	0,50	$2,00 \pm 0,04$	0,15	0,40	0,08	$\pm 0,1$

IEC 60286-3-2-2009

<https://standards.iec.ch/sats/standards/ast/3/8b3ac3-390c-41d5-99aa-3414edb23efb/iec-60286-3-2-2009>

Table 2 – Variable dimensions of carrier tape

Tape size mm	B_1 max mm	E_2 min mm	F mm	P_1 mm	P_2 mm	T_2 max mm	W mm	A_0, B_0, K_0 mm
4	1,48 ^a	3,07	1,8 ± 0,03	1,0 ± 0,03	1,0 ± 0,03	1,1	4,0 ± 0,08	see Note

NOTE The nominal dimensions of the component compartment should be derived from the relevant component specification. The tolerances on the nominal sizes of the compartment should be selected so that the components cannot change their orientation within the tape and can be easily removed from the tape, with the following characteristics.

There should be sufficient clearance surrounding the component so that

- a) the component does not protrude above the top surface of the carrier tape,
- b) the component can be removed from the cavity in a vertical direction without mechanical restriction after the top cover tape has been removed,
- c) the rotation of the component is limited to a 20° maximum tilt (see Figure 3, sketch A) and a 20° maximum planar rotation (see Figure 3, sketch B),
- d) the maximum lateral movement allowed is 0,20 mm except for 0603M sized components where the maximum should be 0,12 mm and for 0402M sized components the maximum should be 0,10 mm.

For defined component positioning the cavity positions should be defined to an origin point. This origin is the centre of the Index hole, defined by the crosshair of the dimensions E_1 and P_0 . The centre of the component compartment is defined by P_2 and F , relative to the sprocket holes, as shown in Figure 1, with tolerances given in the table above.

Preferred dimensions for components should be taken from the relevant IEC specifications.

Dimensions $A_0 \leq B_0$, unless otherwise specified in the component detail specification.

Dimension K_0 should comply with the component tilt in Sketch A.

The off-set between the centre of the component compartment and the centre of the sprocket hole should not be more than 0,03 mm (see Figure 2).

^a Reference dimension.

3 Polarity and orientation of components in the tape

Requirements shall be in accordance with IEC 60286-3, 4.1, 4.2.1 and 4.2.3.

4 Fixing components and additional tape requirements

Requirements shall be in accordance with IEC 60286-3, 5.1, 5.5, 5.7 and 5.8 and the following.

4.1 Tape requirements

4.1.1 The cover tapes shall not cover the sprocket holes.

4.1.2 The adhesive of the cover tape shall not adversely affect the mechanical and electrical characteristics and the marking of the components.

4.1.3 Components shall not stick to the carrier tape or to the cover tape.

4.1.4 The cover tape shall not become detached.