



SLOVENSKI STANDARD

SIST-TS CEN/TS 13763-27:2003

01-december-2003

Eksplozivi za civilno uporabo – Detonatorji in zakasnilniki – 27. del: Definicije, metode in zahteve za elektronske sisteme za aktiviranje

Explosives for civil uses - Detonators and relays - Part 27: Definitions, methods and requirements for electronic initiation systems

Explosivstoffe für zivile Zwecke - Zünder und Verzögerungselemente - Teil 27: Definitionen, Verfahren und Anforderungen an elektronische Zündsysteme

Explosifs a usage civil - Détonateurs et relais - Partie 27: Définitions, méthodes et exigences relatives aux systèmes d'amorçage électronique

<https://standards.iteh.ai/catalog/standards/sist/4bf8a4c7-6f77-46ae-93ca-1eb0a65f2c71/sist-ts-cen-ts-13763-27-2003>

Ta slovenski standard je istoveten z: CEN/TS 13763-27:2003

ICS:

71.100.30 Eksplozivi. Pirotehnika Explosives. Pyrotechnics

SIST-TS CEN/TS 13763-27:2003 en

iTeh STANDARD PREVIEW
(standards.iteh.ai)

[SIST-TS CEN/TS 13763-27:2003](https://standards.iteh.ai/catalog/standards/sist/4bf8a4c7-6f77-46ae-93ca-1eb0a65f2c71/sist-ts-cen-ts-13763-27-2003)

<https://standards.iteh.ai/catalog/standards/sist/4bf8a4c7-6f77-46ae-93ca-1eb0a65f2c71/sist-ts-cen-ts-13763-27-2003>

TECHNICAL SPECIFICATION
SPÉCIFICATION TECHNIQUE
TECHNISCHE SPEZIFIKATION

CEN/TS 13763-27

July 2003

ICS 71.100.30

English version

**Explosives for civil uses – Detonators and relays – Part 27:
Definitions, methods and requirements for electronic initiation
systems**

Explosifs à usage civil – Détonateurs et relais – Partie 27:
Définitions, méthodes et exigences relatives aux systèmes
d'amorçage électronique

Explosivstoffe für zivile Zwecke – Zünder und
Verzögerungselemente – Teil 27: Definitionen, Verfahren
und Anforderungen an elektronische Zündsysteme

This Technical Specification (CEN/TS) was approved by CEN on 19 December 2002 for provisional application.

The period of validity of this CEN/TS is limited initially to three years. After two years the members of CEN will be requested to submit their comments, particularly on the question whether the CEN/TS can be converted into a European Standard.

CEN members are required to announce the existence of this CEN/TS in the same way as for an EN and to make the CEN/TS available. It is permissible to keep conflicting national standards in force (in parallel to the CEN/TS) until the final decision about the possible conversion of the CEN/TS into an EN is reached.

CEN members are the national standards bodies of Austria, Belgium, Czech Republic, Denmark, Finland, France, Germany, Greece, Hungary, Iceland, Ireland, Italy, Luxembourg, Malta, Netherlands, Norway, Portugal, Slovakia, Spain, Sweden, Switzerland and United Kingdom.

[SIST-TS CEN/TS 13763-27:2003](https://standards.iteh.ai/catalog/standards/sist/4bf8a4c7-6f77-46ae-93ca-1eb0a65f2c71/sist-ts-cen-ts-13763-27-2003)

<https://standards.iteh.ai/catalog/standards/sist/4bf8a4c7-6f77-46ae-93ca-1eb0a65f2c71/sist-ts-cen-ts-13763-27-2003>



EUROPEAN COMMITTEE FOR STANDARDIZATION
COMITÉ EUROPÉEN DE NORMALISATION
EUROPÄISCHES KOMITEE FÜR NORMUNG

Management Centre: rue de Stassart, 36 B-1050 Brussels

Contents

	Page
Foreword.....	3
0 Introduction	5
1 Scope	9
2 Normative references	9
3 Terms and definitions.....	10
4 Procedure	12
5 Test report	36
6 Requirements	36
Annex A (informative) Examples of hazards and faults	37
Annex B (informative) Information on evaluation techniques	44
Annex C (informative) Proposals for the detonator fusehead replaced (dummy detonators).....	46
Annex D (informative) Determination of resistance to dynamic pressure	48
Bibliography	49

[SIST-TS CEN/TS 13763-27:2003](https://standards.iteh.ai/catalog/standards/sist/4bf8a4c7-6f77-46ae-93ca-1eb0a65f2c71/sist-ts-cen-ts-13763-27-2003)

<https://standards.iteh.ai/catalog/standards/sist/4bf8a4c7-6f77-46ae-93ca-1eb0a65f2c71/sist-ts-cen-ts-13763-27-2003>

Foreword

This document (CEN/TS 13763-27:2003) has been prepared by Technical Committee CEN/TC 321 "Explosives for civil uses", the secretariat of which is held by AENOR.

This document includes a Bibliography.

Annexes A, B, C and D are informative.

This Technical Specification is one of a series of standards with the generic title *Explosives for civil uses – Detonators and relays*. The other parts of this series are listed below:

- prEN 13763-1 Part 1: Requirements
- EN 13763-2 Part 2: Determination of thermal stability
- EN 13763-3 Part 3: Determination of sensitiveness to impact
- prEN 13763-4 Part 4: Determination of resistance to abrasion of leading wires and shock tubes
- prEN 13763-5 Part 5: Determination of resistance to cutting damage of leading wires and shock tubes
- prEN 13763-6 Part 6: Determination of resistance to cracking in low temperatures of leading wires
- prEN 13763-7 Part 7: Determination of the mechanical strength of leading wires, shock tubes, connections, crimps and closures
- prEN 13763-8 Part 8: Determination of resistance to vibration of plain detonators
- prEN 13763-9 Part 9: Determination of resistance to bending of detonators
- prEN 13763-10 Part 10: Method for the determination of resistance to torsion of sealing plugs
- prEN 13763-11 Part 11: Determination of resistance to damage by dropping of detonators and relays
- prEN 13763-12 Part 12: Determination of resistance to hydrostatic pressure
- prEN 13763-13 Part 13: Determination of resistance of electric detonator to electrostatic discharge
- prEN 13763-14 Part 14: Determination of resistance of electric detonator to the influence of radio frequency radiation
- prEN 13763-15 Part 15: Determination of equivalent initiating capability
- prEN 13763-16 Part 16: Determination of delay accuracy
- prEN 13763-17 Part 17: Determination of no-fire current of electric detonators
- prEN 13763-18 Part 18: Determination of series firing current of electric detonators
- prEN 13763-19 Part 19: Determination of firing pulse of electric detonators
- prEN 13763-20 Part 20: Determination of total resistance of electric detonators
- prEN 13763-21 Part 21: Determination of flash-over voltage of electric detonators

CEN/TS 13763-27:2003 (E)

prEN 13763-22 Part 22: Determination of capacitance, insulation resistance and insulation breakdown of leading wires

EN 13763-23 Part 23: Determination of the shock-wave velocity of shock tube

EN 13763-24 Part 24: Determination of the non-conductivity of shock tube

prEN 13763-25 Part 25: Determination of transfer capacity of relay and coupling accessories

prEN 13763-26 Part 26: Definitions, methods and requirements for devices and accessories for reliable and safe function of detonators and relays.

According to the CEN/CENELEC Internal Regulations, the national standards organizations of the following countries are bound to announce this CEN Technical Specification: Austria, Belgium, Czech Republic, Denmark, Finland, France, Germany, Greece, Hungary, Iceland, Ireland, Italy, Luxembourg, Malta, Netherlands, Norway, Portugal, Slovakia, Spain, Sweden, Switzerland and the United Kingdom.

iTeh STANDARD PREVIEW
(standards.iteh.ai)

[SIST-TS CEN/TS 13763-27:2003](https://standards.iteh.ai/catalog/standards/sist/4bf8a4c7-6f77-46ae-93ca-1eb0a65f2c71/sist-ts-cen-ts-13763-27-2003)

<https://standards.iteh.ai/catalog/standards/sist/4bf8a4c7-6f77-46ae-93ca-1eb0a65f2c71/sist-ts-cen-ts-13763-27-2003>

0 Introduction

0.1 Background and basic principles

Electronic initiation systems have been developed for use in civil blasting work. Detonators in these systems normally have delay times which are far more accurate than conventional detonators with pyrotechnic delay, and are claimed to facilitate better blasting results, e.g. in terms of better fragmentation, reduced ground vibrations, less damage on remaining rock, etc.

From a safety and reliability point of view electronic initiation systems are more complex than conventional electric and non-electric detonator systems, which results in new risk factors.

The aim of this Technical Specification is to reach negligible risks at least at the same applied safety and reliability level as the corresponding standards for conventional electric detonators. This statement should be seen as a general objective of the Technical Specification at a system level and not as a detailed guideline to judge the level of acceptability for individual specific demands. However in some cases the standards for conventional electric detonators referred to in this Technical Specification are applicable in various grades. In these cases the requirement level for electric detonators have been adopted, possibly after some amendments if necessary.

This Technical Specification specifies a risk analysis procedure to be used to investigate the safety and reliability of electronic initiation systems by identifying hazards and estimating the risks associated with the system.

The step in the risk analysis procedure, which refers to acceptability of risks, includes both references to testing and evaluation methods, which apply where appropriate for the specific system. The Technical Specification also stipulates levels of acceptability.

This structure of combining a general risk analysis procedure in combination with specific requirements related to testing and evaluation as well as guidelines for evaluation specified in informative annexes has been chosen for the following reasons:

- The use of electronic initiation systems are highly related to safety of human life and health as well as to property. The safety and reliability of electronic initiation systems depends on a number of factors interacting, which makes the systems complicated to evaluate in these respects. In this Technical Specification relevant risk factors have been addressed to risks of unintended initiation, misfire and incorrect function.
- The need to consider safety and reliability for individual components of the system i.e. detonators, firing/testing/programming units as well as overall system aspects including connection and set-up limits and communication between the different components.
- The need for evaluation of safety-critical electronic hardware and software both in detonators and in firing/testing/programming units.
- Manufacturers of electronic initiation systems have used significantly different design and system solutions in order to fulfil acceptable safety and reliability criteria. The product development in the field is rapid. Therefore the Technical Specification aims to be valid for different system solutions.

Considerable effort has been taken to refer to other parts of prEN 13763 for conventional detonators as far as possible, specifying applicability of these tests as well as possible amendments in order to avoid redundancy and inconsistency.

CEN/TS 13763-27:2003 (E)

Possibilities for non-destructive testing using dummy detonators without explosive content, have been considered as far as possible due to the high costs of electronic detonators.

0.2 Overview of an electronic initiation system

Electronic detonator systems can be fitted in two categories: non-programmable electronic detonators (or fixed delay detonators) and programmable delay detonators. Programmable detonators can be programmed using one-way data communication or two-way data communication. These categories are elaborated upon below:

Non-programmable detonators

This type of detonator does not require any data communications in order to ignite. The connection to the detonator can be electrical or non-electrical. These detonators are normally numbered in such a way that the user recognizes its intended delay time.

Programmable detonators

The delay time of these detonators is programmed prior to blasting, by either the testing unit or the firing unit. This type of detonators usually require electrical connections to facilitate:

- **One-way data communication:** This implies that communication only take place to the detonator. No information is received from the detonator. In these systems, it is vitally important that communications to the detonator are robust.
- **Two-way data communication:** Communication takes place in both directions. Since feedback is received from the detonator, it is possible to establish the state of the detonator. Useful information can include integrity of the communications to the detonator, integrity of the initiation element, the firing capacitor voltage, results of a self-test, etc.

0.3 Block diagram of a generic two wire programmable electronic detonator

Not all components illustrated below are necessarily required in an electronic detonator, at the same time, some components may have been omitted. The purpose of the diagram is to familiarize the reader of this document with some of the functions and components of an electronic detonator, such that the requirements and implications for safe operations may be better understood.

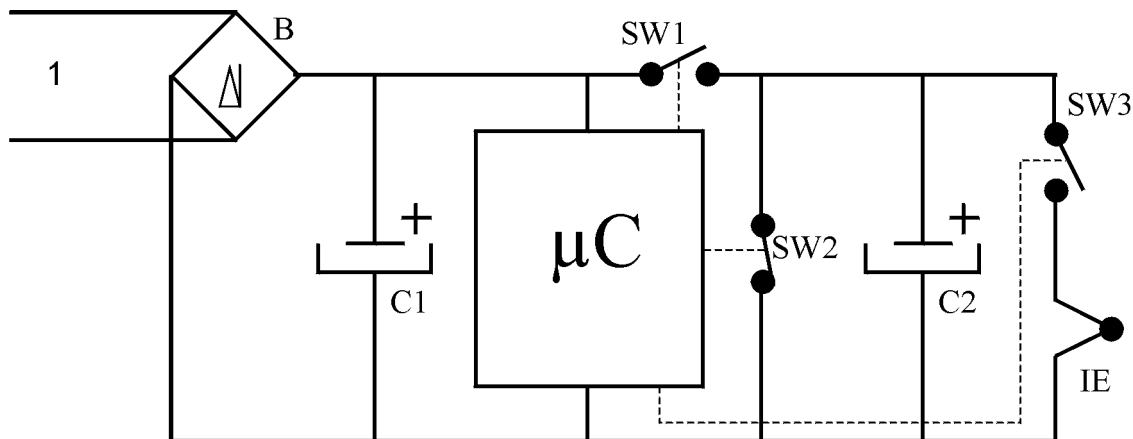
**Key**

- 1 Communication line
- B Full wave rectifier to make the system polarity insensitive (optional)
- C1 Power supply capacitor

C2 Firing capacitor. This capacitor supplies the energy required to fire the initiation element (IE). This capacitor may be disconnected and/or shorted prior to blasting with the aid of SW1 and SW2. C1 and C2 may be separate capacitors, or they may be combined. SW3 will be closed at the time of firing, after C2 had enough energy stored.

Figure 1 – Block diagram of a generic 2-wire programmable electronic detonator

The components illustrated above may be integrated into one or more monolithic circuits.

0.4 Electrical wiring systems

This section refers only to electrical connections. Even though other wiring system may exist, the two most common topologies are:

- **Bus topology**

Each detonator is connected to a common and separate "surface" wire. Usually, a connector is used per detonator.

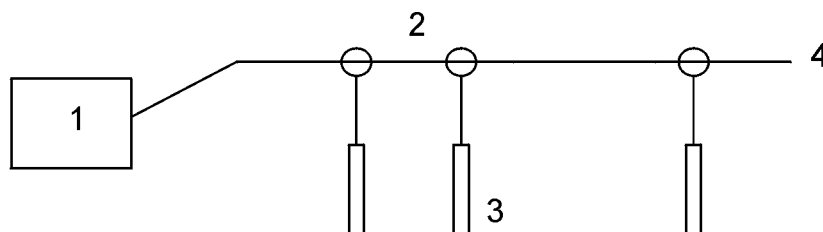
**Key**

- 1 Firing unit
- 2 Connectors
- 3 Detonators
- 4 Surface wire

Figure 2 – Electrical wiring systems - Bus topology

CEN/TS 13763-27:2003 (E)

- **Daisy chain topology**

In this system, a detonator has enough wire to reach the neighbouring detonator, and the tail of the one detonator is connected to the previous detonator. There is thus no separate bus wire. A detonator would usually have one or two connectors.

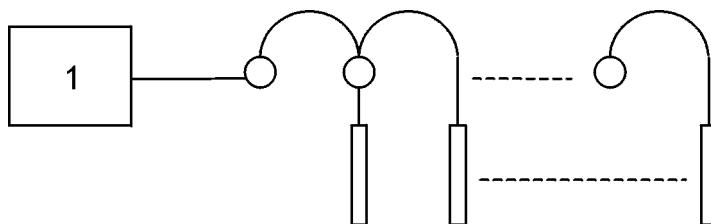
**Key**

1 Firing unit

Figure 3 - Electrical wiring systems - Daisy chain topology

iTeh STANDARD PREVIEW
(standards.iteh.ai)

[SIST-TS CEN/TS 13763-27:2003](https://standards.iteh.ai/catalog/standards/sist/4bf8a4c7-6f77-46ae-93ca-1eb0a65f2c71/sist-ts-cen-ts-13763-27-2003)

<https://standards.iteh.ai/catalog/standards/sist/4bf8a4c7-6f77-46ae-93ca-1eb0a65f2c71/sist-ts-cen-ts-13763-27-2003>

1 Scope

This Technical Specification specifies a risk analysis, evaluation and testing procedure to be used to investigate the safety and reliability of electronic initiation systems by identifying hazards and estimating the risks associated with the system. The Technical Specification also stipulates levels of acceptability for electronic initiation systems.

2 Normative references

This Technical Specification incorporates by dated or undated reference, provisions from other publications. These normative references are cited at the appropriate places in the text, and the publications are listed hereafter. For dated references, subsequent amendments to or revisions of any of these publications apply to this Technical Specification only when incorporated in it by amendment or revision. For undated references the latest edition of the publication referred to applies (including amendments).

prEN 13763-1; *Explosives for civil uses - Detonators and relays — Part 1: Requirements.*

EN 13763-2; *Explosives for civil uses - Detonators and relays — Part 2: Determination of thermal stability.*

EN 13763-3; *Explosives for civil uses - Detonators and relays — Part 3: Determination of sensitiveness to impact.*

prEN 13763-4; *Explosives for civil uses - Detonators and relays — Part 4: Determination of resistance to abrasion of leading wires and shock tubes.*

prEN 13763-5; *Explosives for civil uses - Detonators and relays — Part 5: Determination of resistance to cutting damage of leading wires and shock tubes.*

prEN 13763-6; *Explosives for civil uses - Detonators and relays — Part 6: Determination of resistance to cracking in low temperatures of leading wires.*

prEN 13763-7; *Explosives for civil uses - Detonators and relays — Part 7: Determination of the mechanical strength of leading wires, shock tubes, connections, crimps and closures.*

prEN 13763-8; *Explosives for civil uses - Detonators and relays — Part 8: Determination of resistance to vibration of plain detonators.*

prEN 13763-9; *Explosives for civil uses - Detonators and relays — Part 9: Determination of resistance to bending of detonators.*

prEN 13763-10:2000; *Explosives for civil uses - Detonators and relays — Part 10: Method for the determination of resistance to torsion of sealing plugs.*

prEN 13763-11; *Explosives for civil uses - Detonators and relays — Part 11: Determination of resistance to damage by dropping of detonators and relays.*

prEN 13763-12; *Explosives for civil uses - Detonators and relays — Part 12: Determination of resistance to hydrostatic pressure.*

prEN 13763-13; *Explosives for civil uses - Detonators and relays — Part 13: Determination of resistance of electric detonators against electrostatic discharge.*

prEN 13763-14; *Explosives for civil uses - Detonators and relays — Part 14: Determination of resistance of electric detonators to the influence of radio frequency radiation.*

prEN 13763-15; *Explosives for civil uses - Detonators and relays — Part 15: Determination of equivalent initiating capability.*

prEN 13763-16; *Explosives for civil uses - Detonators and relays — Part 16: Determination of delay accuracy.*

CEN/TS 13763-27:2003 (E)

prEN 13763-17; *Explosives for civil uses - Detonators and relays — Part 17: Determination of no-fire current of electric detonators.*

prEN 13763-18; *Explosives for civil uses - Detonators and relays — Part 18: Determination of series firing current of electric detonators.*

prEN 13763-19; *Explosives for civil uses - Detonators and relays — Part 19: Determination of firing pulse on electric detonators.*

prEN 13763-20; *Explosives for civil uses - Detonators and relays — Part 20: Determination of total resistance of electric detonators.*

prEN 13763-21; *Explosives for civil uses - Detonators and relays — Part 21: Determination of flash-over voltage of electric detonators.*

prEN 13763-22; *Explosives for civil uses - Detonators and relays — Part 22: Determination of capacitance, insulation resistance and insulation breakdown of leading wires.*

EN 13763-23; *Explosives for civil uses - Detonators and relays — Part 23: Determination of the shock-wave velocity of shock tubes.*

EN 13763-24; *Explosives for civil uses - Detonators and relays — Part 24: Determination of the electrical non-conductivity of shock tubes.*

prEN 13763-25; *Explosives for civil uses - Detonators and relays — Part 25: Determination of transfer capacity of relay and coupling accessories.*

prEN 13763-26; *Explosives for civil uses - Detonators and relays — Part 26: Definitions, methods and requirements for devices and accessories for reliable and safe function of detonators and relays.*

prEN 13857-1; *Explosives for civil uses — Part 1: Terminology.*

EN 60870-5-1; *Telecontrol equipment and systems — Part 5: Transmission protocols — Section 1: Transmission frame formats (IEC 60870-5-1:1990).*

EN 61000-4-3; *Electromagnetic compatibility (EMC) — Part 4-3: Testing and measurement techniques. Radiated, radio-frequency, electromagnetic field immunity test (IEC 61000-4-3:2002).*

EN 61000-4-6; *Electromagnetic compatibility (EMC) — Part 4: Testing and measurement techniques — Section 6: Immunity to conducted disturbances, induced by radio-frequency fields (IEC 61000-4-6:1996).*

EN 61496-1:1997; *Safety of machinery – Electro-sensitive protective equipment — Part 1: General requirements and tests (IEC 61496-1:1997)*

EN ISO/IEC 17025; *General requirements for the competence of testing and calibration laboratories (ISO/IEC 17025:1999).*

IEC 60068-2-14; *Environmental testing — Part 2: Tests - Test N: Change of temperature (IEC 60068-2-14:1984 + A1:1986).*

3 Terms and definitions

For the purposes of this Technical Specification the terms and definitions given in prEN 13857-1 and the following apply.

3.1**electronic initiation system**

system generally composed of a firing unit and/or a testing unit and/or a programming unit, and a certain number of electronic detonators

3.2**electronic detonator**

electronic detonator as defined in prEN13857-1

3.3**non programmable electronic detonator**

electronic detonator with a programmed delay time. This programming is made by the manufacturer.

3.4**pre-programmed electronic detonator**

electronic detonator with a pre programmed delay number programmed by the manufacturer. The firing time of these detonators is a multiple of this delay number and is determined on the field.

3.5**programmable electronic detonator**

electronic detonator of which the functioning delay time is programmable, on the field, by mean of a programming unit and/or a firing unit

3.6**firing unit**

apparatus used in an electronic initiation system to initiate a blast. Such a device can control and/or program and/or test the electronic detonators and charge the firing capacitor of the electronic detonators before the initiation of the blast. This device can be driven by a computer.

3.7**testing unit**

field tester intended, in an electronic initiation system, to test the electronic detonators and/or the initiating circuit. This tester should not be able to initiate the electronic detonator.

3.8**programming unit**

apparatus used, on the field, to program a delay time and/or an address to a programmable electronic detonator. This apparatus can also test the electronic detonator. This apparatus should not be able to initiate the electronic detonator.

3.9**electronic initiation system using no data communication**

electronic initiation system in which the electronic detonator receives only firing energy from the firing unit (e.g. by non-electric or electric means)

3.10**electronic initiation system using one way data communication**

electronic initiation system in which the electronic detonator may receive commands from the programming/testing unit and/or from firing unit but cannot send back any information to PROGRAMMING/TESTING and/or to firing unit

3.11**electronic initiation system using two way data communication**

electronic initiation system in which the electronic detonator may receive commands from the programming/testing unit and/or to firing unit and send back information to PROGRAMMING/TESTING and/or from firing unit

3.12**critical defect**

defect that, according to judgement and experience, is likely to result in hazardous or unsafe conditions for individuals using, maintaining or depending upon the considered product; or that is likely to prevent performance of the function of a major end item e.g. an unintended initiation caused during transport, storage and handling

CEN/TS 13763-27:2003 (E)**3.13****major defect**

defect, other than critical, that is likely to result in failure, or to reduce materially the usability of the considered product for its intended purpose, e.g. misfire of more than one detonator in a blasting round

3.14**minor defect**

defect that is not likely to reduce materially the usability of the considered product for its intended purpose, or that is a departure from established specifications having little bearing on the effective use or operation of this product, e.g. misfire of one single detonator or incorrect function (delay time) of a detonator

NOTE The above defect criteria are specific to electronic initiation systems and apply to all components of the system.

3.15**fault**

state of an entity characterized by the inaptitude to achieve an intended function

3.16**failure**

suspension of the aptitude of an entity to achieve a necessary function. After a failure, the entity is in fault.

3.17**independent circuits**

two circuits are independent if they are physically separated and if a failure of one circuit cannot put the second one in fault

iTeh STANDARD PREVIEW
(standards.iteh.ai)

4 Procedure**4.1 General (step 1 of Figure 4)**

[SIST-TS CEN/TS 13763-27:2003](https://standards.iteh.ai/catalog/standards/sist/4bf8a4c7-6f77-46ae-93ca-bb1c6d09181c/sist-13763-27-2003)

[https://standards.iteh.ai/catalog/standards/sist/4bf8a4c7-6f77-46ae-93ca-](https://standards.iteh.ai/catalog/standards/sist/4bf8a4c7-6f77-46ae-93ca-bb1c6d09181c/sist-13763-27-2003)

The risk analysis, evaluation and testing procedure, as described in 4.2 to clause 5 and illustrated in the flow diagram given in Figure 4.

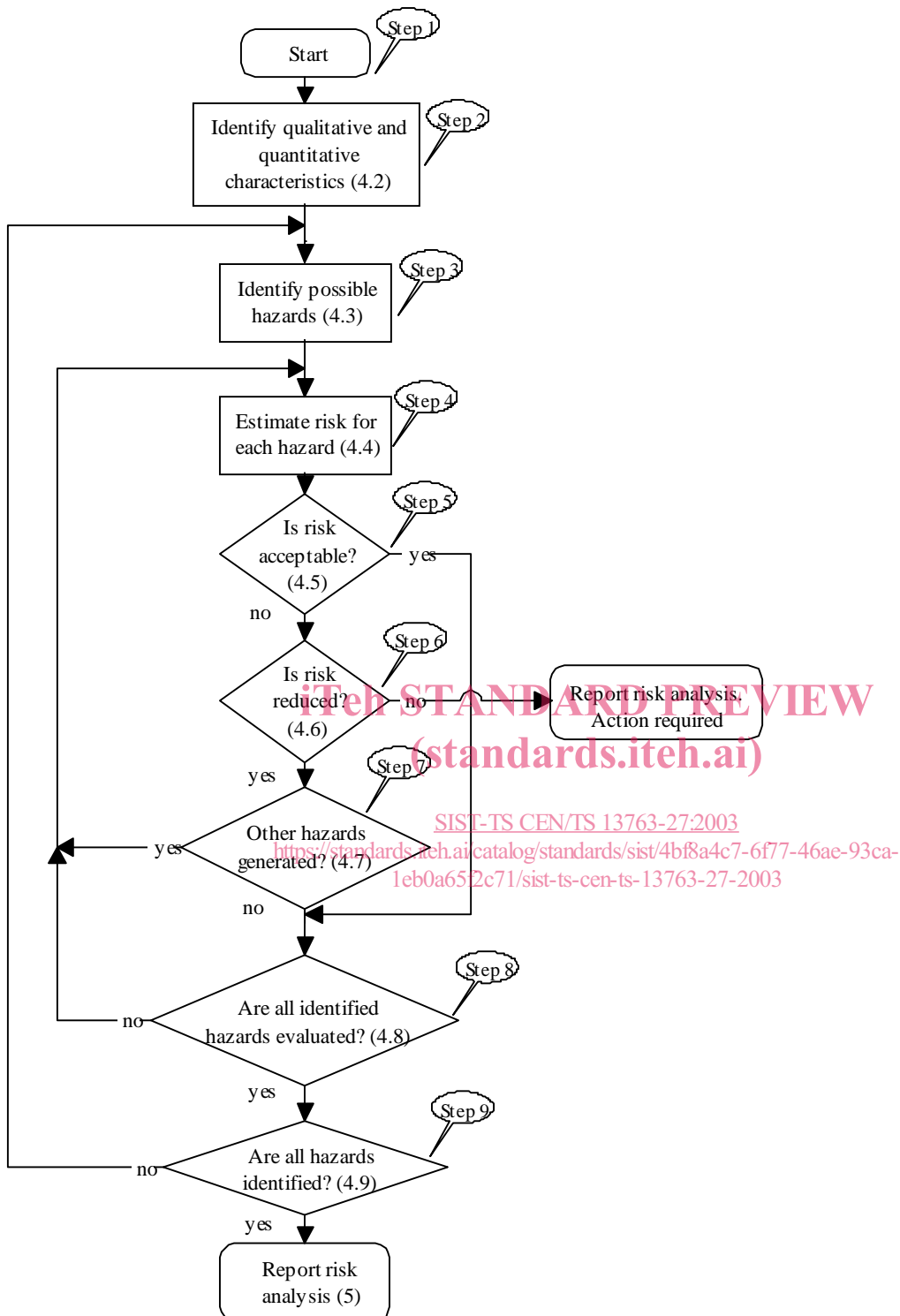

Figure 4 - Flow diagram of risk analysis, evaluation and testing procedure