



Designation: D 2512 – 95 (Reapproved 2002)

Standard Test Method for Compatibility of Materials with Liquid Oxygen (Impact Sensitivity Threshold and Pass-Fail Techniques)¹

This standard is issued under the fixed designation D 2512; the number immediately following the designation indicates the year of original adoption or, in the case of revision, the year of last revision. A number in parentheses indicates the year of last reapproval. A superscript epsilon (ϵ) indicates an editorial change since the last revision or reapproval.

This standard has been approved for use by agencies of the Department of Defense.

1. Scope

1.1 This method^{2,3,4} covers the determination of compatibility and relative sensitivity of materials with liquid oxygen under impact energy using the Army Ballistic Missile Agency (ABMA)-type impact tester. Materials that are impact-sensitive with liquid oxygen are generally also sensitive to reaction by other forms of energy in the presence of oxygen.

1.2 *This standard should be used to measure and describe the properties of materials, products, or assemblies in response to heat and flame under controlled laboratory conditions and should not be used to describe or appraise the fire hazard or fire risk of materials, products, or assemblies under actual fire conditions. However, results of this test may be used as elements of a fire risk assessment which takes into account all of the factors which are pertinent to an assessment of the fire hazard of a particular end use.*

1.3 *This standard does not purport to address all of the safety concerns, if any, associated with its use. It is the responsibility of the user of this standard to establish appropriate safety and health practices and determine the applicability of regulatory limitations prior to use.*

2. Referenced Documents

2.1 ASTM Standards:

- C 145 Specification for Solid Load-Bearing Concrete Masonry Units⁵
- D 1193 Specification for Reagent Water⁶

¹ This test method is under the jurisdiction of ASTM Committee G04 on Compatibility and Sensitivity of Materials in Oxygen Enriched Atmospheres and is the direct responsibility of Subcommittee G04.01 on Test Methods.

Current edition approved Feb. 15, 1995. Published April 1995. Originally published as D 2512 – 66. Last previous edition D 2512 – 82 (1994)^{e1}.

² "NASA Handbook 8060. 1B, Ambient LOX Mechanical Impact Screening Test," September 1981, pp. 4-53 through 4-71. "Oxygen Systems." George C. Marshall Space Flight Center, National Aeronautics and Space Administration. Specification MSFC 106B. September 1981.

³ "Lubrication and Related Research and Test Method Development for Aviation Propulsion Systems." Technical Report No. 59-726. Wright Air Development Division, January 1960.

⁴ "General Safety Precautions for Missile Liquid Propellants."

⁵ Annual Book of ASTM Standards, Vol 04.05.

⁶ Annual Book of ASTM Standards, Vol 11.01.

2.2 Military Standards:

- MIL-D-16791G Detergent, General Purpose (Liquid, Non-ionic)⁷
- MIL-P-27401C Propellant Pressurizing Agent, Nitrogen⁷
- MIL-PRF-25508F Propellant, Oxygen⁷
- MIL-T-27602B Trichloroethylene, Oxygen Propellant Compatible⁸
- MIL-C-81302D Cleaning Compound, Solvent, Trichlorotrifluorocarbon⁷

3. Summary of Test Method

3.1 A sample of the test material is placed in a specimen cup, precooled and covered with liquid oxygen, and placed in the cup holder located in the anvil region assembly of the impact tester. A precooled striker pin is then centered in the cup. The plummet is dropped from selected heights onto the pin, which transmits the energy to the test specimen. Observation for any reaction is made and the liquid oxygen impact sensitivity of the test material is noted. Drop tests are continued using a fresh specimen cup and striker pin for each drop, until the threshold valve is achieved. A series of drop tests are conducted at an energy level of 98 J (72 ft-lbf) or as specified for the pass-fail tests.

4. Significance and Use

4.1 When this test method is used to measure the threshold impact sensitivity of a material, a relative sensitivity assessment is obtained which permits the ranking of materials.

4.2 This test method may also be used for acceptance-testing materials for use in liquid oxygen systems. Twenty separate samples of the material submerged in liquid oxygen are subjected to 98 J (72 ft-lbf) or as specified. Impact energy delivered through a 12.7-mm (1/2-in.) diameter contact. More than one indication of sensitivity is cause for immediate rejection. A single explosion, flash, or other indication of

⁷ Available from Standardization Documents Order Desk, Bldg. 4 Section D, 700 Robbins Ave., Philadelphia, PA 19111-5098, Attn: NPODS.

⁸ Cancelled in 1983. Previously available from Standardization Documents Order Desk, Bldg. 4 Section D, 700 Robbins Ave., Philadelphia, PA 19111-5098, Attn: NPODS.

sensitivity during the initial series of 20 tests requires that an additional 40 samples be tested without incident to ensure acceptability of the material.

4.3 The threshold values are determined by this test method at ambient pressure. The sensitivity of materials to mechanical impact is known to increase with increasing pressure. Since most liquid oxygen systems operate at pressures above ambient condition, some consideration should be given to increased sensitivity and reactivity of materials at higher pressure when selecting materials for use in pressurized system.

5. Apparatus

5.1 *ABMA-Type Impact Tester*⁹ (Fig. 1), for determining the sensitivity of materials to liquid oxygen with impact energy. Fig. 2 shows the schematic diagram of the typical power supply. The tester consists of the following parts:

5.1.1 *Three Guide Tracks*, capable of maintaining accurate vertical alignment under repeated shock conditions.

5.1.2 *Plummet*, with a weight of 9.072 ± 0.023 kg (20 ± 0.05 lbs).

5.1.3 *Safety Catch*, operated by a solenoid, and designed to hold the plummet near the base of the magnet. It is used to support the plummet in the event of a power failure.

5.1.4 *Electromagnet*, for supporting or releasing the plummet. The electromagnet is designed to hold 9.072 kg (20 lbs) of weight with a minimum amount of electrical energy.

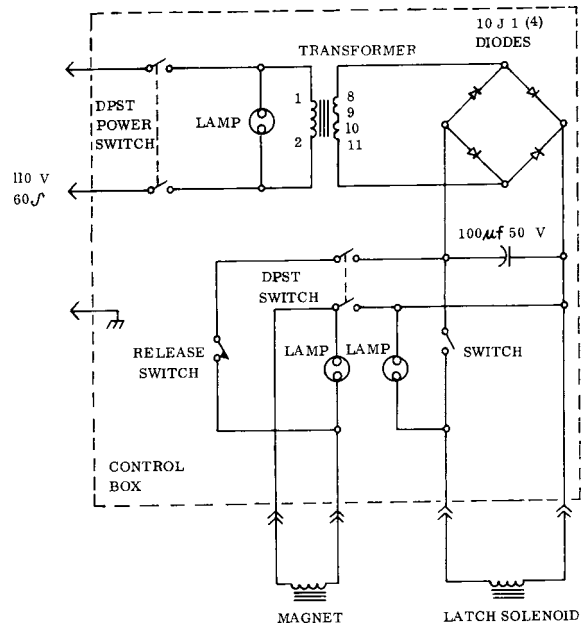

FIG. 2 Schematic Diagram of Power Supply

5.1.5 *Base*—The base of the tester is composed of the following: a rigid 0.61- by 0.61- by 0.61-m (2- by 2- by 2-ft) (min) reinforced concrete block (concrete conforming to Specification C 145), a 3.2-mm (1/8-in.) stainless steel sheet, and a 25-mm (1-in.) thick stainless steel base plate. Four stainless steel foundation bolts protruding from the concrete block are used to fasten the plate and sheet to the smooth surface of the concrete block with stainless steel nuts.

NOTE 1—Where not otherwise indicated, stainless steel shall be of the AISI 300 series.

5.1.6 *Anvil Plate* (Fig. 3), made from a 51-mm (2-in.) thick

⁹ Detailed drawings for the ABMA-Type Impact Tester and Anvil Region Assembly are available from ASTM International Headquarters. Order Adjunct ADJD2512.

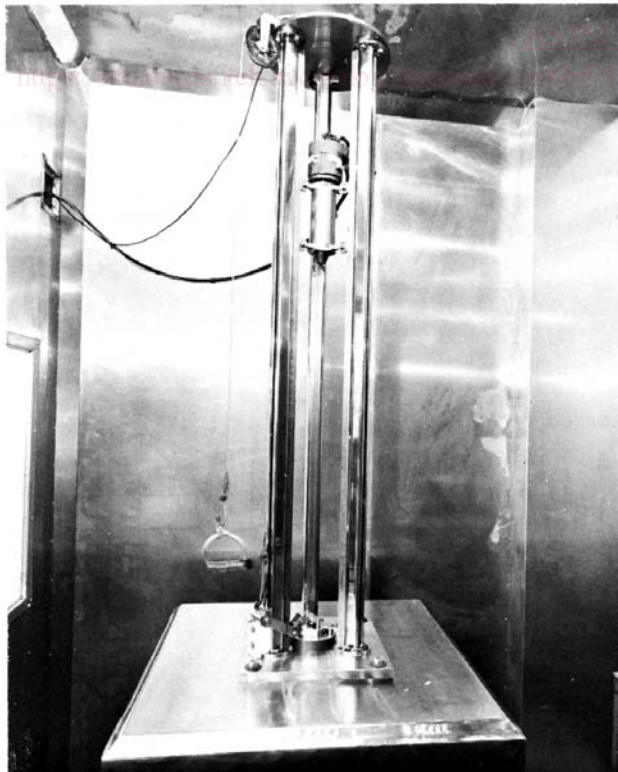

FIG. 1 ABMA-Type Impact Tester

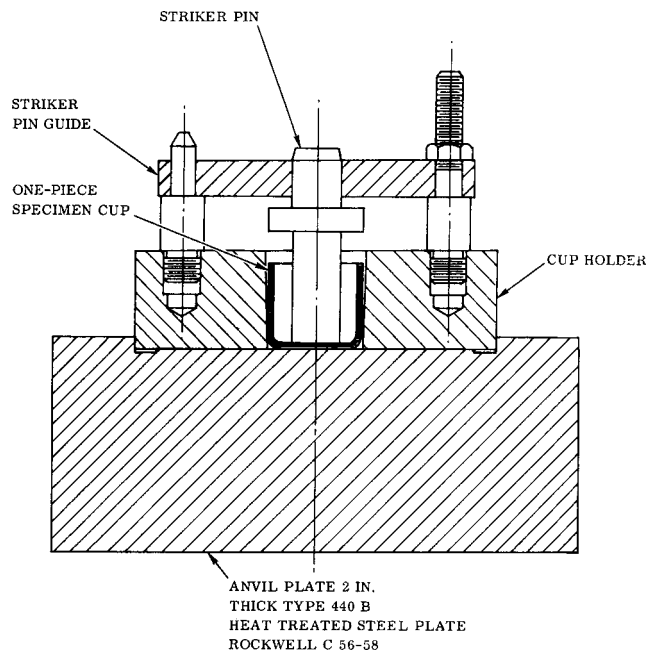

FIG. 3 Anvil Region Assembly

Type 440B heat-treated steel plate, (56 to 58 HRC) that is centered and rests on the base plate. It in turn centers the specimen cup holder.

5.1.7 *Striker Pin*—The striker pins shall be machined from AMS 5643D stainless steel, heat condition H-900 (Fig. 4).

5.1.8 *Striker Pin Guide*.

5.1.9 *Specimen Cups*—One- and two-piece specimen cups shall be used. The one-piece specimen cup (Fig. 5) shall be used for liquid and solid test materials. When testing hard samples that are sometimes capable of initiating reactions with the aluminum cup, expendable Type 347 stainless steel disks 17.5 mm (1¹/₁₆ in.) in diameter by 1.6 mm (1¹/₁₆ in.) thick shall be placed in the bottom of the cup. The two-piece cup (Fig. 6) shall be used for testing semisolid materials; a one-piece insert cup (Fig. 7) may also be used. The recess of either of these permits use of a 1.27-mm (0.050-in.) thick sample.

5.1.10 *Specimen Cup Holder*, consisting of a 25-mm (1-in.) thick stainless steel block centered on the anvil plate. This holder has two protruding spacers which align the striker pin guide, and in turn the striker pin, with the nose of the plummet, thus ensuring a direct hit by the nose of the plummet on the striker pin in the specimen cup.

5.2 *Test Cell*—The impact tester shall be housed in a test cell containing a concrete floor. Walls shall be constructed of reinforced concrete or metal to provide protection from explosion or fire hazards. The cell shall be provided with a shatterproof observation window, and shall be darkened sufficiently to permit observation of flashes. The operator shall be located in a darkened area. Continuous ventilation shall provide fresh air to the test cell. Construction of the cell shall be directed at providing a facility that can be maintained economically at a high level of good housekeeping. The test cell shall be cleaned periodically to ensure cleanliness of sample and equipment.

5.3 *Freezing Box*, as illustrated in Fig. 8.

5.4 *Auxiliary Equipment*—The auxiliary equipment shall consist of forceps for handling the specimen cups and striker pins, stainless steel spatulas, liquid oxygen handling equipment

such as stainless steel Dewar flasks, liquid oxygen protective gloves, lintless laboratory coat, eye protection equipment, and liquid oxygen storage containers. Special handling equipment shall include striker pin holders (Fig. 9), specimen cup trays, covered storage container for specimen cups and striker pins, and a vapor-phase degreaser. The following items are also recommended: microburet, control panel with switches to activate the safety catch and electromagnet, stereomicroscope, micrometer depth gage with leveling blocks, press punch cutter for preparation of plastic specimens, oven, and refrigerator. For checking surface roughness of striker pins and specimen cups, a set of visual roughness comparison standards¹⁰ or a surface roughness measuring instrument shall be required. Timing instrumentation shall be required to measure the drop time of the plummet. A suitable free-fall timing circuit is illustrated in Fig. 10.

6. Reagents and Materials

6.1 *Alkaline Cleaner*, for striker pins and stainless steel inserts, consisting of a solution of 15 g of sodium hydroxide (NaOH), 15 g of trisodium phosphate (Na₃PO₄), and 1 L of distilled or deionized water.

6.2 *Alkaline Cleaner*, for cups; a nonetch-type solution such as Enthone NE¹¹ or equivalent shall be used.

6.3 *Aqua Regia*—Mix 18 parts of concentrated HNO₃ (sp gr 1.42) with 82 parts of concentrated hydrochloric acid (HCl, sp gr 1.19) by volume.

6.4 *Deionized Water*, conforming to Specification D 1193.

6.5 *Detergent, General-Purpose (Liquid, Nonionic)*, conforming to MIL-D-16791G.

6.6 *Hydrofluoric Acid* (48.0 to 51.0 %)—Reagent grade concentrated hydrofluoric acid (HF).

6.7 *Liquid Nitrogen*, conforming to MIL-P-27401C. (**Warning**—Contact with the skin can cause frostbites resembling burns.)

6.8 *Gaseous Nitrogen*, conforming to MIL-P-27401C. (**Warning**—Compressed gas under high pressure. Always use a pressure regulator. Release regulator tension before opening cylinder.)

6.9 *Liquid Oxygen*, conforming to MIL-PRF-25508F. (**Warning**—Oxygen vigorously accelerates combustion. Contact with skin can cause frostbite resembling burns.)

6.10 *Nitric Acid* (relative density 1.42)—Reagent grade nitric acid (HNO₃).

6.11 *Trichloroethylene*, conforming to MIL-T-27602. (**Warning**—Harmful if inhaled. High concentrations may cause unconsciousness or death. Contact may cause skin irritation and dermatitis.)

NOTE 2—The use of trichloroethylene is banned in California by the California Air Pollution Board.

6.12 **Trichlorotrifluoroethane**, conforming to MIL-C-81302D Type I. (**Warning**—Harmful if inhaled.)

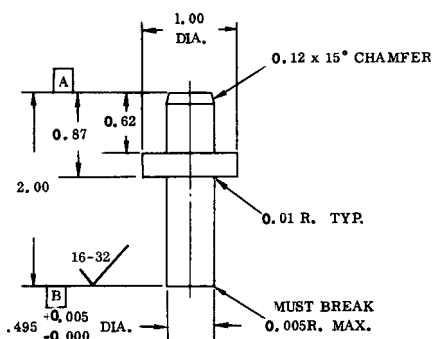

NOTE 1—Break sharp edges approximately 0.015.

NOTE 2—Machine all surfaces 32 rms except as noted.

NOTE 3—Material: stainless steel AMS 5643 D.

NOTE 4—Heat treatment: H-900 to obtain Rc 43 to 44.

NOTE 5—Finish: electropolish after heat treatment.

NOTE 6—Surfaces A and B should be parallel and perpendicular to the center line within 0.001TIR and 16-32 rms along a radius.

All dimensions in inches.

FIG. 4 Striker Pin

¹⁰ American National Standard B 46.1-1962. Surface Texture standards may be used.

¹¹ Available from Enthone, Inc., a division of American Smelting and Refining Co., Box 1900, New Haven, CT 06508.

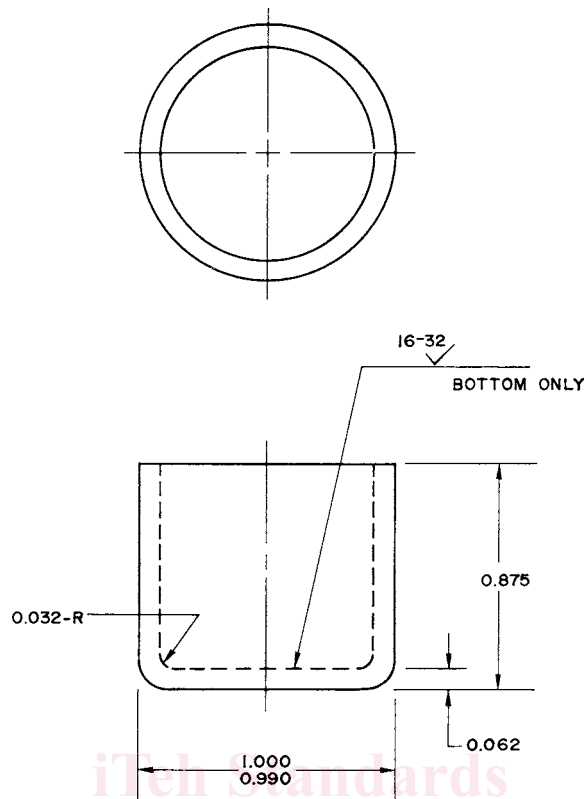

NOTE 1—Break sharp edges 0.015.

NOTE 2—The cup is formed by deep drawing.

NOTE 3—The thickness and parallelness of the cup bottom shall be controlled to 0.0610 to 0.0630 by coining.

NOTE 4—Material: aluminum alloy QQ-A-318 (5052) temper H32.

All dimensions in inches.

FIG. 5 One-Piece Specimen Cup

7. Safety Precautions

7.1 The hazards involved with liquid oxygen are very serious. Contact with the skin can cause frostbites resembling burns. Contact with hydrocarbons or other fuels causes an explosion hazard, as such mixtures are usually shock, impact, and vibration-sensitive.

7.2 The first-aid procedure for liquid oxygen contact is to flush the affected area with water. This treatment should be followed by medical attention. A safety shower must be available in the immediate area.

7.3 The following safety rules must be observed: personnel working with liquid oxygen must be familiar with its nature and characteristics. Approved goggles or face shields, protective clothing, gloves, and boots must be worn during handling or transfer. Such operations shall be performed by not less than two persons as a group. Extreme caution shall be exercised in preventing contact with oils or other combustible materials. All tools must be degreased before use. Precautions shall be taken to prevent accumulation of moisture in lines, valves, traps, and so forth to avert freezing and plugging with subsequent pressure ruptures. Care shall also be taken to prevent entrapment of liquid oxygen in unvented sections of any system.

7.4 Safety shower and other protective equipment shall be inspected periodically and before each handling of liquid oxygen. Personnel leaving the working or storage area shall

take steps to make sure that no oxygen remains absorbed in clothing before smoking or approaching any source of ignition.

7.5 The threshold limit value, that is, the time-weighted average concentration of trichloroethylene believed safe for continuous exposure during a normal 8-h workday, has been established by the American Conference of Governmental Industrial Hygienists at 100 ppm. Operations using trichloroethylene should always be conducted in a well-ventilated area. The comparable figure for trichlorotrifluoroethane is 1000 ppm, and normal ventilation is usually adequate. When a ventilation system is used, an effort should be made to have the natural air currents in the vicinity assist rather than oppose the mechanical ventilation. For cleaning by vapor degreasing, the vapor level shall be controlled by heat input and cooling coils, which establish a vapor “ceiling.” Such vapor degreasing units should always be installed in a location that is free from draft conditions and should be ventilated by horizontal slot exhausts.

8. Preparation of Apparatus

8.1 *General*—The impact tester, its accessories, and the test cell shall be maintained in clean condition to ensure reproducibility of results and to meet the requirements of blank testing as described in 8.5. The guide tracks, plummet, anvil plate, striker pin guide, specimen cup holder, and base plate of the impact tester shall be cleaned thoroughly at the start of each

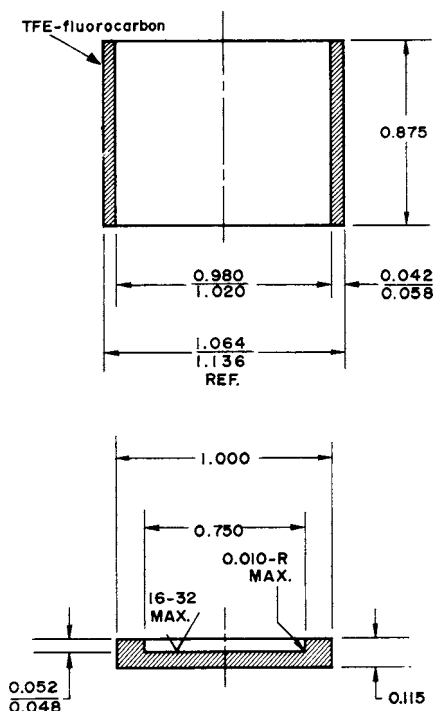

NOTE 1—Break sharp edges 0.015.
 NOTE 2—Surfaces marked shall be parallel within 0.002 TIR.
 NOTE 3—Material: aluminum alloy QQ-A-318 (5052), temper H-32.
 All dimensions in inches.

FIG. 6 Two-Piece Specimen Cup

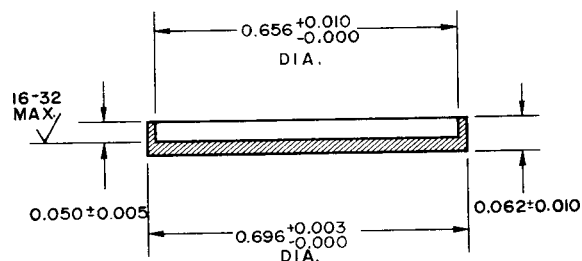
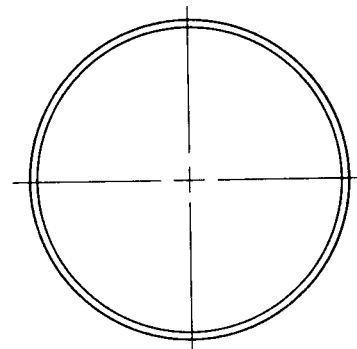

NOTE 1—Material: aluminum alloy QQ-A-318 (5052), temper H-32.
 All dimensions in inches.

FIG. 7 One-Piece Insert Cup

test and between tests of different materials by using cheesecloth soaked with fresh trichloroethylene or trichlorotrifluoroethane. In addition, the anvil plate, specimen cup holder, striker pin guide, and plummet nose shall be cleaned with fresh trichloroethylene or trichlorotrifluoroethane at least after every tenth impact during a test series. After completion of testing for the day, the impact tester handling equipment (Dewar flasks and forceps), and sample preparation equipment, shall be rinsed with fresh trichloroethylene or trichlorotrifluoroethane.

8.2 *Striker Pins and Insert Disks*—Before each test, the striker pin shall be checked for dimensional conformance to drawing and then examined to ensure freedom from scratches, nicks, metallic slivers, and other imperfections. The striker pins shall be cleaned, adhering to a specified cleaning sequence. Fig. 9 shows a suitable striker pin holder which holds as many as 24 striker pins. By using such a tool during the entire handling of the pins, the striking surfaces of the pins are protected from possible damage as a result of handling. The pins shall be placed in the striker pin holder, rinsed in liquid trichloroethylene or trichlorotrifluoroethane, and vapor-degreased for 5 min. This sequence shall be followed with an air dry. The striker pins shall be immersed in an alkaline cleaner (see 6.1) for a minimum of 15 min at 20 to 35°C. This procedure shall be followed by a rinse in running tap water and then a rinse in distilled or deionized water. The striker pins shall then be dried in an oven at 125 to 150°C until free of water. They shall be removed from the oven and stored in a

suitable covered container. The stainless steel insert disks shall be handled in an analogous manner through the same cleaning steps.

8.3 *Specimen Cups*—The one-piece cup, lower part of the two-piece specimen cup, and one-piece insert (Fig. 5, Fig. 6, and Fig. 7, respectively) are made of aluminum alloy. They shall be cleaned as follows: vapor degrease in trichloroethylene in an inverted position for 15 min. Rinse with tap water. Soak for 20 min in hot alkaline cleaner (see 6.2). Rinse thoroughly with deionized water. Immerse for 15 min at ambient temperature in a mixture of the following: 0.5 volume % of concentrated HF (48 %), 5.0 volume % of concentrated HNO₃ (relative density 1.42), and 94.5 volume % of deionized water. Rinse with deionized water. Desmut by immersing at 20 to 35°C in a 50 volume % solution of concentrated HNO₃ (relative density 1.42) in deionized water for 5 min or until smut is removed. Rinse thoroughly with deionized water. Dry in an oven at 125 to 150°C until free of water. The cups shall not be used until at least 72 h after cleaning.

8.4 *Sleeve for Two-Piece Specimen Cup*—The cup includes a sleeve made of polytetrafluoroethylene (PTFE). This sleeve shall be cleaned as follows: soak in aqua regia for a minimum of 10 min. Rinse with tap water; rinse with detergent; rinse with distilled or deionized water, drain for a minimum of 10 min, and rinse with trichloroethylene or trichlorotrifluoroethane. Dry in an oven at 125 to 150°C until free from water. The sleeves may be used as soon as they are cooled.

8.5 A liquid oxygen cleanliness check (blank) shall be performed with at least 20 cleaned specimen cups and striker pins selected at random from every batch cleaned. The blank

