

INTERNATIONAL STANDARD

ISO
8307

First edition
1990-12-01

Flexible cellular polymeric materials — Determination of resilience

iTeh STANDARD PREVIEW
*Matériaux polymères alvéolaires souples — Détermination de la
résilience*
(standards.iteh.ai)

[ISO 8307:1990](#)

[https://standards.iteh.ai/catalog/standards/sist/f6465684-8dae-4a70-903a-
b8446e58e388/iso-8307-1990](https://standards.iteh.ai/catalog/standards/sist/f6465684-8dae-4a70-903a-b8446e58e388/iso-8307-1990)



Reference number
ISO 8307:1990(E)

Foreword

ISO (the International Organization for Standardization) is a worldwide federation of national standards bodies (ISO member bodies). The work of preparing International Standards is normally carried out through ISO technical committees. Each member body interested in a subject for which a technical committee has been established has the right to be represented on that committee. International organizations, governmental and non-governmental, in liaison with ISO, also take part in the work. ISO collaborates closely with the International Electrotechnical Commission (IEC) on all matters of electrotechnical standardization.

Draft International Standards adopted by the technical committees are circulated to the member bodies for voting. Publication as an International Standard requires approval by at least 75 % of the member bodies casting a vote.

International Standard ISO 8307 was prepared by Technical Committee ISO/TC 45, *Rubber and rubber products*.

iTeh STANDARD PREVIEW
(standards.iteh.ai)

[ISO 8307:1990](https://standards.iteh.ai/catalog/standards/sist/f6465684-8dae-4a70-903a-b8446e58e388/iso-8307-1990)

<https://standards.iteh.ai/catalog/standards/sist/f6465684-8dae-4a70-903a-b8446e58e388/iso-8307-1990>

© ISO 1990

All rights reserved. No part of this publication may be reproduced or utilized in any form or by any means, electronic or mechanical, including photocopying and microfilm, without permission in writing from the publisher.

International Organization for Standardization
Case Postale 56 • CH-1211 Genève 20 • Switzerland

Printed in Switzerland

Flexible cellular polymeric materials — Determination of resilience

1 Scope

This International Standard specifies a test method for determining the resilience of flexible cellular polymeric materials.

2 Normative reference

The following standard contains provisions which through reference in this text, constitute provisions of this International Standard. At the time of publication, the edition indicated was valid. All standards are subject to revision, and parties to agreements based on this International Standard are encouraged to investigate the possibility of applying the most recent edition of the standard indicated below. Members of IEC and ISO maintain registers of currently valid International Standards.

ISO 471:1983, *Rubber — Standard temperatures, humidities and times for the conditioning and testing of test pieces.*

3 Definitions

For the purposes of this International Standard, the following definitions apply.

3.1 open-cell flexible cellular material: Flexible cellular material with less than 25 % of its cell volume closed.

3.2 closed-cell flexible cellular material: Flexible cellular material with more than 25 % of its cell volume closed.

4 Principle

A steel ball is dropped on to a test piece from a specified height and the height of rebound is measured.

5 Apparatus (see figure 1)

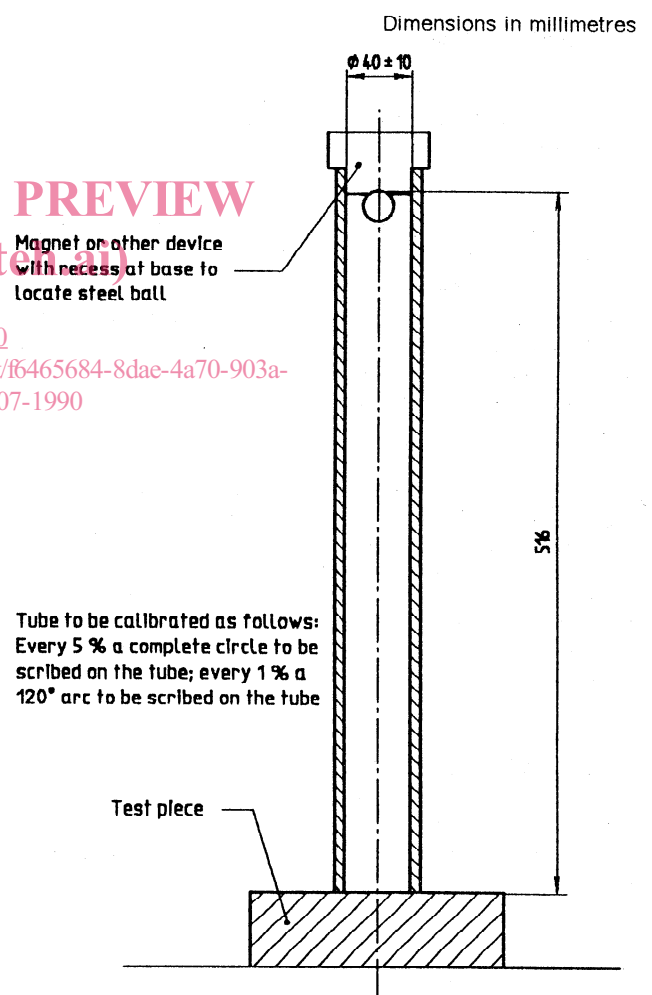

Figure 1 — Diagrammatic arrangement for test apparatus

The ball rebound test apparatus shall consist of a 40 mm \pm 10 mm inside diameter vertical transparent tube, into which a 16 mm \pm 0,5 mm diameter steel ball with a mass of 16 g \pm 0,5 g is released by a magnet or other device. The steel ball shall be released so that it falls without rotation and is effectively centred. The height of the drop shall be 500 mm \pm 0,5 mm. Since it is most convenient to note the position of the top of the ball on rebound, the top of the ball shall be 516 mm above the surface of the test piece. Thus, "zero" rebound shall be the diameter of the ball above the specimen surface.

The scale on the back of the tube shall be calibrated directly in per cent as follows: every 5 % (25 mm) a complete circle shall be scribed and at every 1 % a 120° arc shall be scribed on the tube. The complete circles are an essential part of the apparatus, since they are used to eliminate parallax error.

6 Test pieces

6.1 The test pieces shall have plane, parallel top and bottom surfaces.

6.2 The test pieces shall consist of the entire product sample or a suitable portion of it, except that in no case shall the thickness be less than 50 mm, or the area less than 100 mm \times 100 mm. Test pieces less than 50 mm thick shall be plied up without the use of cement, to a minimum of 50 mm. For moulded products, the top skin shall be removed.

NOTE 1 The minimum test piece thickness of 50 mm may not be sufficient for very soft materials: if spuriously high results are obtained, a thicker test piece should be used. Very low density materials may also cause problems due to rebound of the test piece itself. Interply snuffing can occur with multiple-ply test pieces. This problem can be overcome by using the largest possible area of test piece.

7 Number of test pieces

Three test pieces per sample shall be tested. The three test pieces may be obtained by using separate items or different locations on a given item.

8 Test conditions

Material shall be tested not less than 72 h after manufacture, unless, at either 16 h or 48 h after manufacture, it can be demonstrated that the mean rebound resilience values obtained do not differ by more than \pm 10 % from those obtained after 72 h. Testing is permitted at either 16 h or 48 h if, at the selected time, the above criterion has been satisfied.

Prior to the test, the test pieces shall be conditioned undeflected and undistorted for at least 16 h in one of the following atmospheres as given in ISO 471:

23 °C \pm 2 °C, (50 \pm 5) % relative humidity;

27 °C \pm 2 °C, (65 \pm 5) % relative humidity.

This period can form the latter part of the period following manufacture.

9 Procedure

9.1 Preflex conditioning

Open-cell material as defined in 3.1 shall be subjected to a preflex conditioning before testing. Preflex the test piece by compressing it twice to 75 % to 80 % of its original thickness at 0,4 mm/s to 6 mm/s, then allow the test piece to rest for a period of 10 min \pm 5 min.

NOTE 2 This preflex conditioning is not applicable to closed-cell material as defined in 3.2.

9.2 Test method

9.2.1 Centre the test piece at the base of the tube (see clause 5) and adjust the height of the tube so that zero rebound is 16 mm above the surface of the test piece.

9.2.2 Mount the steel ball on the release mechanism, then drop it and note the maximum rebound height. If the ball strikes the tube on the drop or rebound, the value obtained is invalid. This condition is usually due to the tube not being vertical or irregularities on the test piece surface. In order to minimize parallax error, the eye-level of the observer shall be such that the markings on the tube in the region where the percentage rebound is read appear as straight lines. Trial drops are necessary in order to establish the correct eye-level.

9.2.3 At least three rebound values in succession within 1 min shall be obtained on each of the three test pieces.

10 Expression of results

For each test piece, determine the median of the three rebound values. If any value deviates by more than 20 % (one-fifth) of the median value from the median, make two additional drops and determine the median for all five rebound values. Using the three median values obtained for the three test pieces, determine the overall median value as the rebound resilience value of the material.

11 Precision statement

At the present time, a precision statement is not available for this test method.

12 Test report

The test report shall include the following information:

- a) a reference to this International Standard;
- b) a description of the material tested, including whether open-cell or closed-cell as defined in clause 3;
- c) the temperature and humidity at which the test piece was conditioned and tested;
- d) the rebound resilience value as the median of the three test piece medians;
- e) the individual values of the three tests per test piece;
- f) the material lot number or date of manufacture;
- g) the date of the test.

iTeh STANDARD PREVIEW
(standards.iteh.ai)

[ISO 8307:1990](https://standards.iteh.ai/catalog/standards/sist/f6465684-8dae-4a70-903a-b8446e58e388/iso-8307-1990)

<https://standards.iteh.ai/catalog/standards/sist/f6465684-8dae-4a70-903a-b8446e58e388/iso-8307-1990>

iTeh STANDARD PREVIEW
(standards.iteh.ai)

This page intentionally left blank

ISO 8307:1990

<https://standards.iteh.ai/catalog/standards/sist/f6465684-8dae-4a70-903a-b8446e58e388/iso-8307-1990>

iTeh STANDARD PREVIEW
(standards.iteh.ai)

This page intentionally left blank

[ISO 8307:1990](#)

<https://standards.iteh.ai/catalog/standards/sist/f6465684-8dae-4a70-903a-b8446e58e388/iso-8307-1990>

iTeh STANDARD PREVIEW
(standards.iteh.ai)

ISO 8307:1990

<https://standards.iteh.ai/catalog/standards/sist/f6465684-8dae-4a70-903a-b8446e58e388/iso-8307-1990>

UDC 678-405.8:620.178.311.6

Descriptors: rubber, plastics, polymers, flexible cellular materials, tests, determination, resilience.

Price based on 3 pages
