

---

International Standard



8313

---

INTERNATIONAL ORGANIZATION FOR STANDARDIZATION • МЕЖДУНАРОДНАЯ ОРГАНИЗАЦИЯ ПО СТАНДАРТИЗАЦИИ • ORGANISATION INTERNATIONALE DE NORMALISATION

---

**Earth-moving machinery — Loaders — Methods of measuring tool forces and tipping loads**

*Engins de terrassement — Chargeuses — Méthodes de mesurage des forces de l'outil et des charges de basculement*

**First edition — 1986-06-15**

---

**UDC 621.869 : 531.781**

**Ref. No. ISO 8313-1986 (E)**

**Descriptors :** earth moving equipment, loaders, tests, measurement, loads (forces).

Price based on 7 pages

## Foreword

ISO (the International Organization for Standardization) is a worldwide federation of national standards bodies (ISO member bodies). The work of preparing International Standards is normally carried out through ISO technical committees. Each member body interested in a subject for which a technical committee has been established has the right to be represented on that committee. International organizations, governmental and non-governmental, in liaison with ISO, also take part in the work.

Draft International Standards adopted by the technical committees are circulated to the member bodies for approval before their acceptance as International Standards by the ISO Council. They are approved in accordance with ISO procedures requiring at least 75 % approval by the member bodies voting.

International Standard ISO 8313 was prepared by Technical Committee ISO/TC 127, *Earth-moving machinery*.

Users should note that all International Standards undergo revision from time to time and that any reference made herein to any other International Standard implies its latest edition, unless otherwise stated.

# Earth-moving machinery — Loaders — Methods of measuring tool forces and tipping loads

## 1 Scope

This International Standard specifies methods for determining the tool forces and tipping loads of loaders, together with their limiting conditions.

## 2 Field of application

This International Standard applies to wheel and crawler loaders as defined in ISO 6165 (see also ISO 7131).

## 3 References

ISO 5998, *Earth-moving machinery — Rated operating load for crawler and wheel loaders.*

ISO 6016, *Earth-moving machinery — Methods of measuring the masses of whole machines, their equipment and components.*

ISO 6165, *Earth-moving machinery — Basic types — Vocabulary.*

ISO 6746/1, *Earth-moving machinery — Definitions of dimensions and symbols — Part 1: Base machines.*

ISO 7131, *Earth-moving machinery — Loaders — Terminology and commercial specifications.*

ISO 7546, *Earth-moving machinery — Loader and front loading excavator buckets — Volumetric ratings.*

## 4 Definitions

For the purposes of this International Standard the following definitions apply.

### 4.1 Tool forces

**4.1.1 breakout force:** Maximum sustained vertical upward force generated at a point 100 mm behind the lip of the bucket, when operating the lift cylinders or the tilt cylinders, and with the bottom of the cutting edge parallel with and 20 mm above GRP (ground reference plane).

For buckets with a curved or pointed cutting edge, the forces shall be measured at the centre of the bucket width.

**4.1.2 lifting capacity:** Maximum load which can be lifted in the bucket from the ground to full height using the lift cylinders, with the bucket tilted back and the load being applied through the centroid of the rated bucket volume (as specified in ISO 7546).

**4.2 tipping load (at maximum outreach or at a specified height):** Minimum mass acting downwards through the centroid of the rated bucket volume which will rotate the machine to the following tipping limiting conditions (see also 4.5.3 and 8.1):

a) On crawler loaders

For rigid frame suspensions the tipping load is determined when the front track rollers are fully off the track (see figure 1). For other types of suspension the method of determining tipping load shall be specified by the manufacturer and shall be reported.

b) On wheel loaders

The tipping load is determined when at least one of the rear wheels is fully off the ground.

In this limit condition the machine is in balance between the overturning moment supplied by the tipping load and the righting moment supplied by the mass of the machine.

**4.3 mass:** Operating mass of the machine, as defined in ISO 6016.

### 4.4 Hydraulic pressure

**4.4.1 system hydraulic pressure:** Nominal pressure measured near the outlet of the pump (the system relief valve pressure).

**4.4.2 circuit relief pressure:** Maximum pressure at each circuit (e.g. the lift or bucket cylinder) which is secured by a circuit relief valve.

### 4.5 Limiting conditions (see also 8.1)

**4.5.1 hydraulic limiting condition:** Moment when the tool forces or lift capacity are limited by any relief valve pressure setting.

**4.5.2 engine stall limiting condition:** Moment when the tool forces are limited by the engine stalling.

**4.5.3 tipping limiting condition:** Moment when the tool forces are limited by the onset of tipping of the machine.

## 5 Apparatus

The apparatus shall comprise the following.

**5.1 Load cell or force transducer** appropriate to the magnitude of the tool force to be measured and with an accuracy of  $\pm 2\%$  inclusive of the readout device.

**5.2 Wire ropes and shackles, pulley, safety chains and adjustable anchor point frames.**

**5.3 Hydraulic oil pressure gauge**, with an accuracy of  $\pm 2\%$ .

**5.4 Apparatus for measuring linear dimensions** to an accuracy of  $\pm 2\%$ .

## 6 Test site

The test site shall consist of a substantially level, hard surface, preferably concrete, with anchor points and sufficient space to use load cells (5.1).

NOTE — In the preferred method (shown in figures 2 and 3) the force to be measured is applied direct to the load cell (5.1). If the force is applied via a pulley, its friction should be taken into account in order to maintain the overall accuracy of  $\pm 2\%$ . As the mass of the rope may affect the accuracy, it is recommended that the rope should be as short as possible.

## 7 Preparation for test

The loader shall be clean, and generally equipped as indicated in ISO 6016.

The machine shall be fitted with the bucket or other attachment and appropriate counterweights, and shall have the tyre pressure and tyre ballast as specified by the manufacturer.

For the purposes of the test, any teeth may be removed to facilitate the attachment of the rope (5.2) from the bucket to the load cell (5.1).

Prior to testing, the engine and hydraulic system shall attain the normal working temperature, and the hydraulic system pressure(s) shall then be checked for compliance with the manufacturer's recommended hydraulic pressure setting(s).

The equipment shall then be positioned on the test site (clause 6) and the test equipment arranged to conduct the tests. Typical arrangements are illustrated in figures 2 to 5.

During actual loading tests, the transmission shall be placed in neutral and the brakes released.

## 8 Methods of measuring tool forces

### 8.1 General

The test shall be conducted with the machine running in accordance with the manufacturer's operating instructions and observing all safety rules.

Safety chains (5.2) shall be fitted to prevent the machine from actually overturning in any test where the tipping limiting condition may occur.

The loader shall be positioned on the test area and the bucket suitably attached to a load cell as illustrated in figures 2 and 3 depending on the test to be conducted.

With the engine running at the manufacturer's maximum recommended speed the required cylinder(s) shall be operated independently and the force at the bucket lip or attachment recorded.

The limiting condition as defined in 4.5 shall be noted for each test (see 10.2).

In the case of the hydraulic limiting condition the report should note the system or circuit in which the relief pressure was exceeded. If the tipping limiting condition is reached, the tool force shall be measured after the onset of tipping.

Safety chains shall be loose so that the machine can attain the tipping condition and yet be prevented from overturning.

Each test shall be conducted three times, and the maximum force for each test shall be noted; the arithmetic mean of these three values shall be recorded in the test results.

The tool forces shall be measured in accordance with the above general requirements and the specific requirements given in 8.2 to 8.4 and as illustrated in the related figures.

### 8.2 Maximum breakout force using lift cylinders

The bottom of the cutting edge shall be parallel with and 20 mm above GRP. On wheel loaders the front axle shall be blocked up at the axle centreline so as to maintain this dimension. The rope shall be attached 100 mm behind the bucket lip and shall be substantially vertical (see figure 2).

### 8.3 Maximum breakout force using tilt cylinders

In order to prevent linkage movement, the bucket shall be supported by a wooden block beneath the bucket pivot with the bottom of the cutting edge parallel with and 20 mm above GRP. The rope shall be attached 100 mm behind the bucket lip and shall be substantially vertical (see figure 3).

### 8.4 Lifting capacity to full lift height

The lifting capacity to full height shall be measured by loading the bucket with metal blocks so that the line of force from the centre of gravity of the load passes through the centroid of the rated bucket volume. The loads shall be increased until the lift cylinders are just able to lift the load to full height or until the tipping load is reached. The load lifted shall be recorded together with the limiting condition, i.e. hydraulic, tipping, or engine stall (see figure 4).

An alternative method of applying a reactive force equivalent to this load, by a rope incorporating a load cell, may also be used. The line of force may be moved to a more convenient point such as the bucket pivot pin and then the equivalent load

at the centroid of the rated bucket volume calculated. The measured load shall be generated by operating the machine hydraulics and not by the force on the rope. The rope shall be substantially vertical at every position of the bucket.

NOTE — The lifting capacity to full height as measured here is the lifting capacity which the loader can achieve in all bucket positions as defined in ISO 5998, and which is one of the two factors which determine the rated operating load.

## 9 Method of measuring tipping load

### 9.1 At maximum outreach

The tipping load shall be measured at maximum radius, i.e. with the lift arm pivots and bucket pivots at equal height above ground level before the load is applied (see figure 5).

Loads shall be placed in the bucket as in 8.4 and shall be increased until the tipping load is reached. The machine hydraulic system shall not be operated during this test, that is the loader is not required to lift this load. Alternatively, the tipping load shall be measured by applying a force through a rope attached to the bucket from a dynamometer or cylinder incorporating a load cell, such that the rope shall be substantially vertical and its line of force pass through the centroid of the rated bucket volume.

For articulated loaders, i.e. pivot steering by a central chassis pivot, the tests shall be conducted with the steering central (zero degrees articulation) and also fully articulated.

NOTE — The tipping load at maximum outreach is the other of the two factors which determine the rated operated load (as defined in ISO 5998).

### 9.2 At specified height

The tipping load shall be measured with the bucket pivot at a height as specified by the manufacturer before the load is applied. The method shall be as in 9.1.

## 10 Test report

### 10.1 General information on machine

The following information shall be reported.

#### 10.1.1 Machine:

- a) type;
- b) model;
- c) manufacturer;
- d) mass of machine as tested (in accordance with ISO 6016), in kilograms;
- e) hydraulic system pressure setting(s), in megapascals.

#### 10.1.2 Type of undercarriage (crawler or wheel mounted):

- a) **Crawler machine** (in accordance with ISO 6746/1):
  - 1) type of track shoe,
  - 2) maximum width (over tracks),  $W1$ , in metres,
  - 3) track gauge,  $W2$ , in metres,
  - 4) track shoe width,  $W4$ , in metres,
  - 5) crawler base (distance between vertical centrelines of front and rear idlers or sprocket),  $L2$ , in metres;
- b) **Wheeled machine** (in accordance with ISO 6746/1):
  - 1) track,  $W3$ , (specifying front and rear if different), in metres,
  - 2) wheel base,  $L3$ , in metres,
  - 3) tyre size(s),
  - 4) tyre pressure, in kilopascals,
  - 5) ballast (if specified), in kilograms,
  - 6) articulation angle (where relevant),  $A1$ .

#### 10.1.3 Bucket fitted for each test:

- a) type;
- b) rated volume (in accordance with ISO 7546);
- c) mass, in kilograms.

10.2 Reporting results

The tool forces and tipping loads shall be recorded in accordance with the following table.

Table – Test results

Description	Force N	Limiting conditions
<b>Maximum breakout force using:</b> – Lift cylinder(s) – Tilt cylinder(s)		
<b>Lifting capacity</b> to full height		
<b>Tipping load</b> a) At maximum outreach: – crawler loader – wheel loader articulated steer – wheel loader front-rear steer – wheel loader all-wheel steer at maximum angle b) At specified height: bucket pivot height, mm		

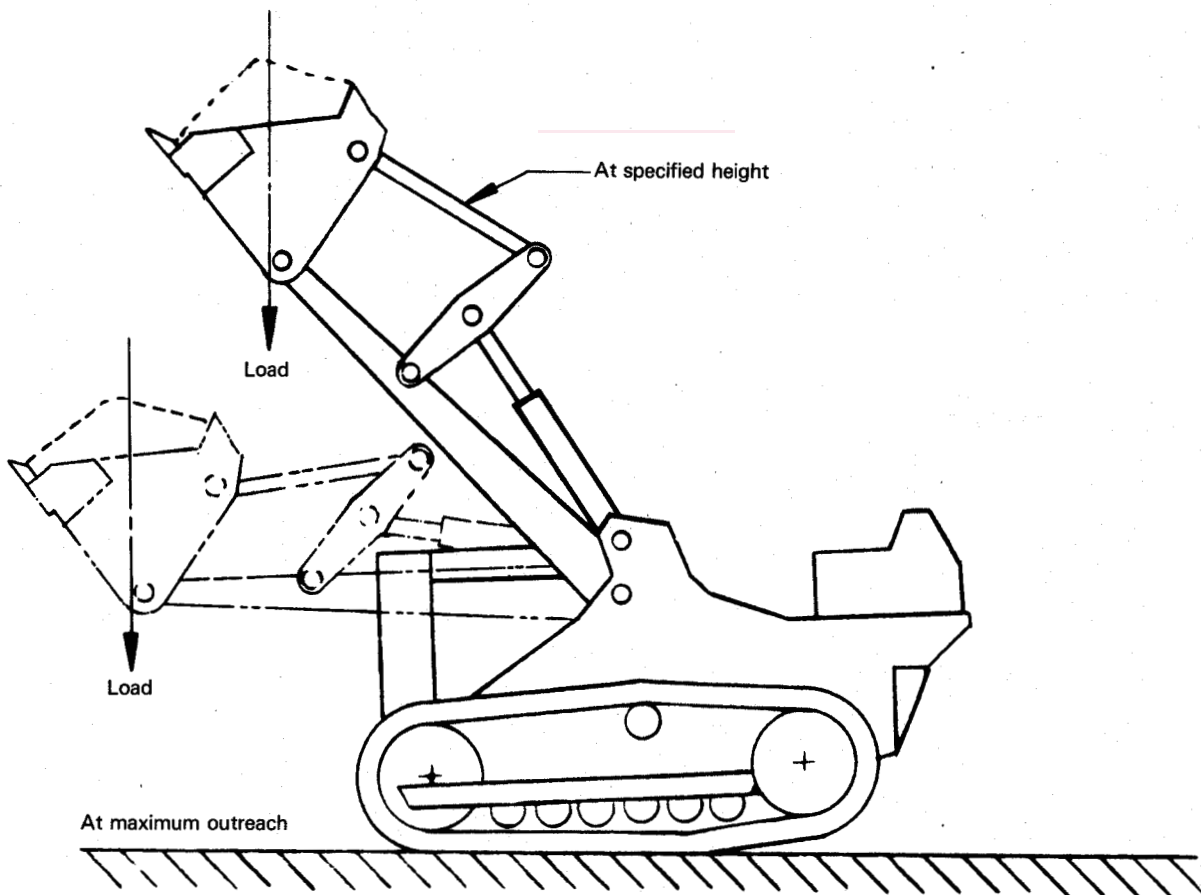

Figure 1 – Tipping condition

Dimensions in millimetres

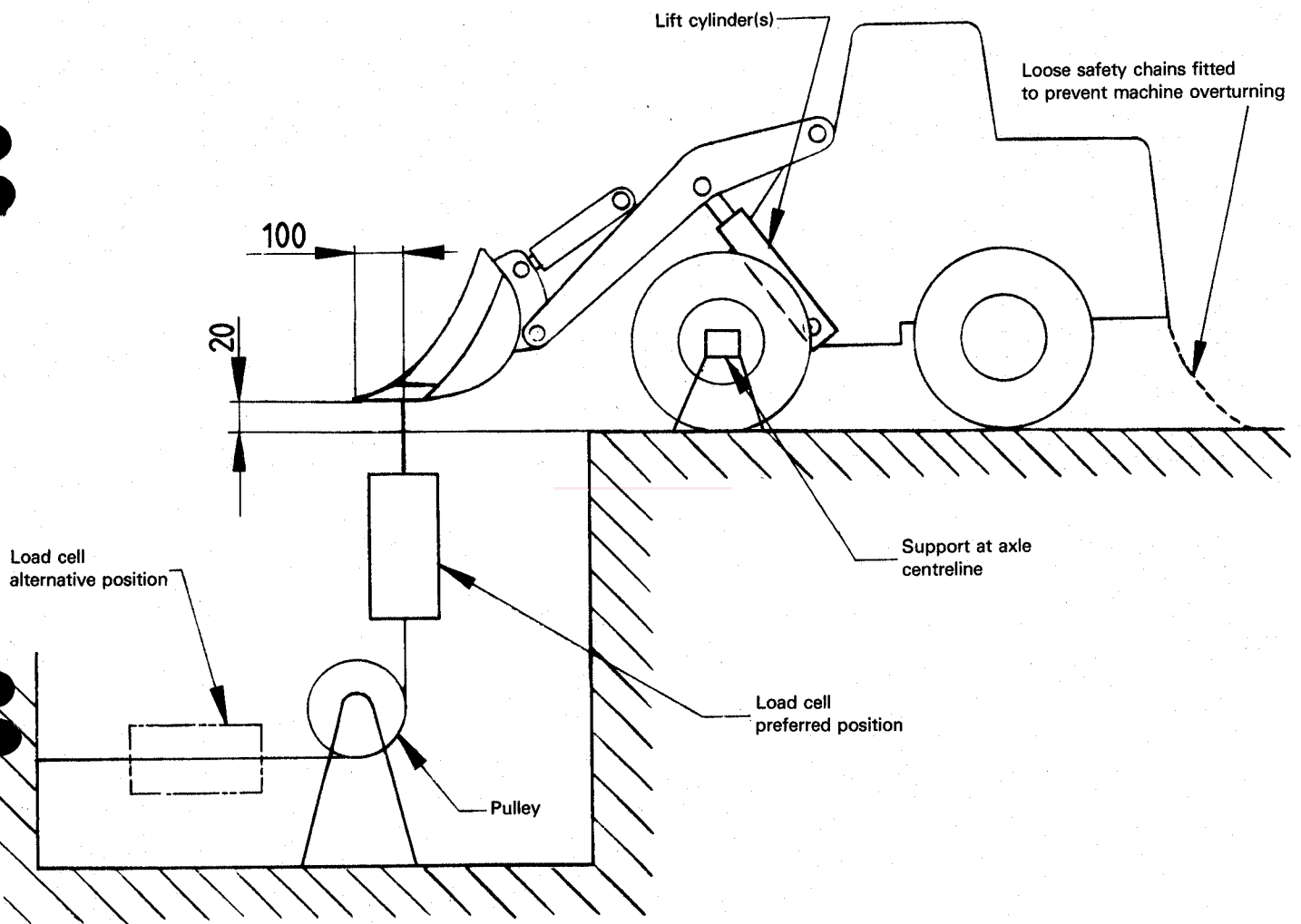

Figure 2 — Typical test arrangement for determination of maximum breakout force exerted by lift cylinder(s)

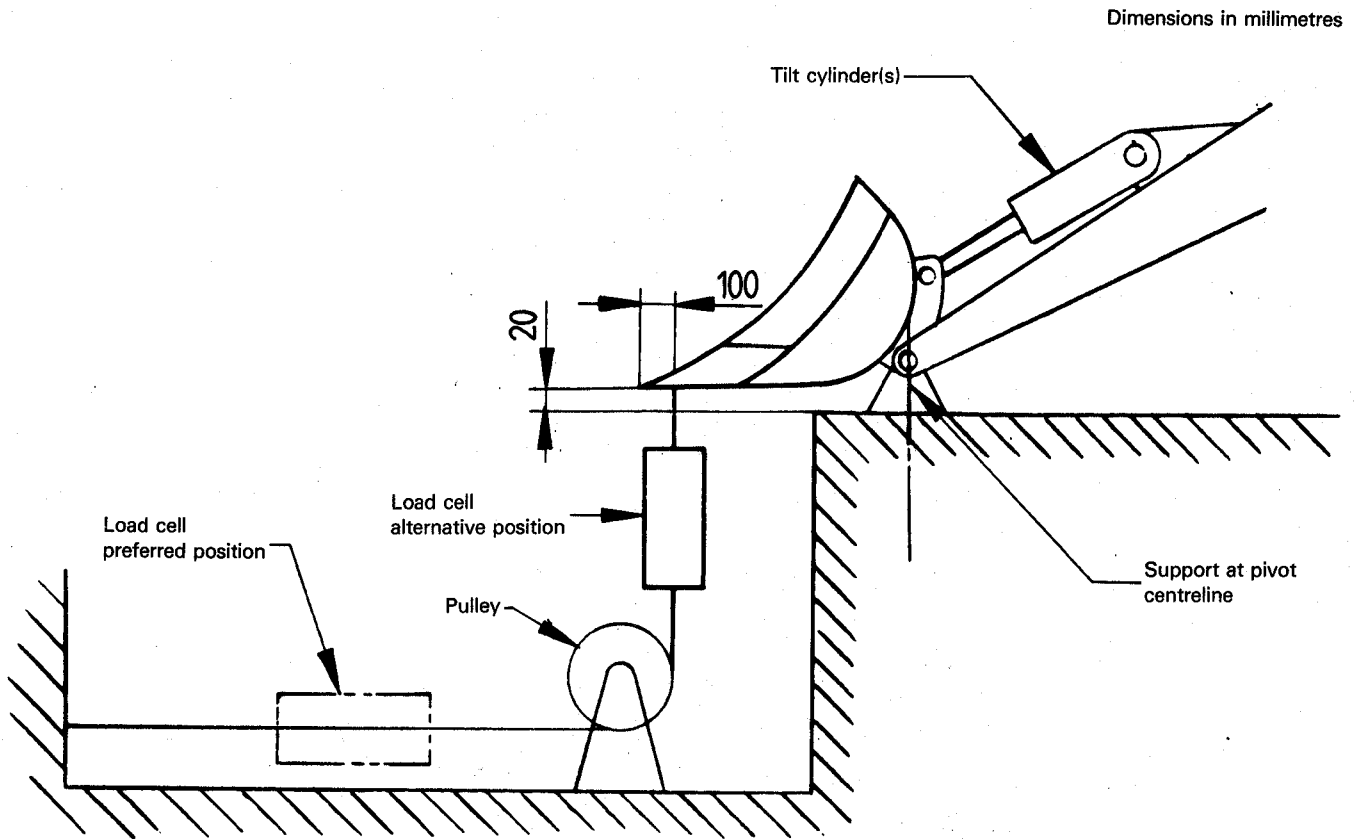

Figure 3 — Typical test arrangement for determination of maximum breakout force exerted by tilt cylinder(s)

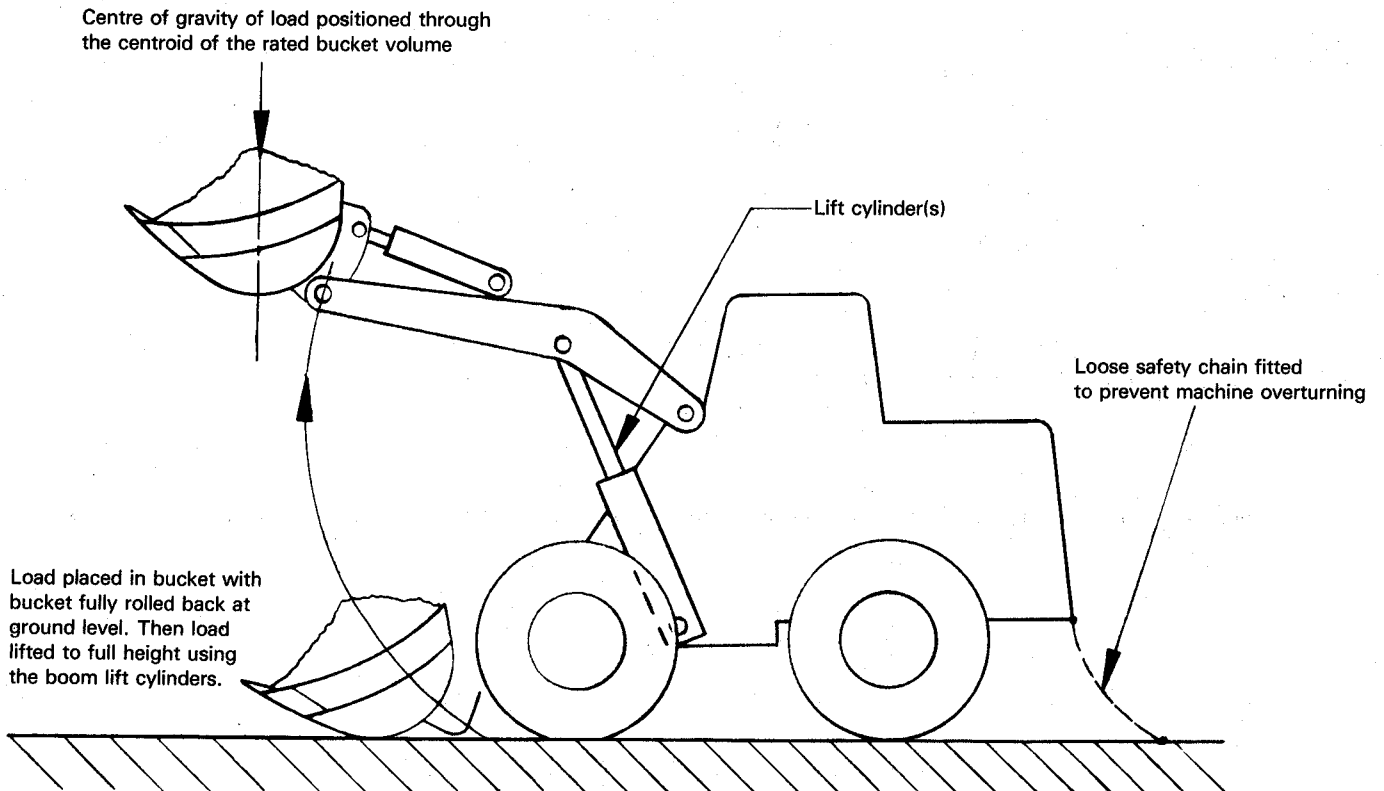

Figure 4 — Typical test arrangement for determination of maximum lifting capacity to full height



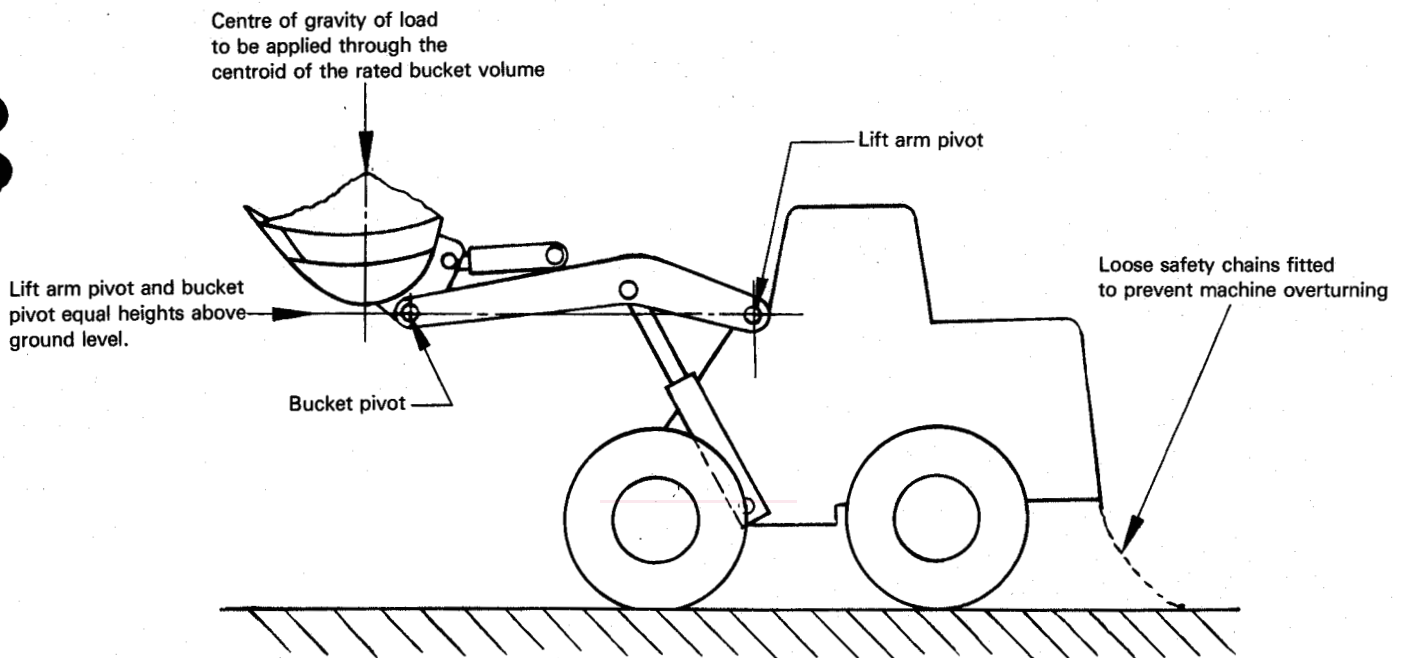

Figure 5 — Typical test arrangement for determination of maximum tipping load at maximum outreach

**iTeh STANDARD PREVIEW**  
**(standards.iteh.ai)**

ISO 8313:1986

<https://standards.iteh.ai/catalog/standards/sist/0416f1f3-4ab9-4ae5-a55e-73af1dda4ee2/iso-8313-1986>