

# INTERNATIONAL STANDARD

**ISO**  
**8336**

First edition  
1993-09-01

---

---

## **Fibre-cement flat sheets**

*Plaques planes en fibres-ciment*

**iTeh STANDARD PREVIEW**  
**(standards.iteh.ai)**

ISO 8336:1993

<https://standards.iteh.ai/catalog/standards/sist/23c2ef4c-e7ba-4e4d-9c00-fec292cd1601/iso-8336-1993>



Reference number  
ISO 8336:1993(E)

## Contents

	Page
1 Scope .....	1
2 Normative references .....	1
3 General composition .....	1
4 Classification .....	1
4.1 Type A .....	1
4.2 Type B .....	2
5 Acceptance characteristics .....	2
5.1 Dimensional and geometrical characteristics .....	2
5.2 Mechanical and physical characteristics .....	2
6 Type characteristics .....	3
6.1 Bending strength .....	3
6.2 Water permeability .....	3
6.3 Frost resistance .....	3
6.4 Warm water .....	3
6.5 Heat-rain .....	3
6.6 Soak-dry .....	3
7 Tests .....	3
7.1 Acceptance tests .....	3
7.2 Type-tests .....	4
7.3 Systems tests .....	4
8 Test methods .....	4
8.1 Acceptance tests .....	4
8.2 Type-tests .....	8
9 Marking .....	11
10 Conformity with standards .....	11

iTeh STANDARD PREVIEW  
(standards.iteh.ai)

ISO 8336:1993

<https://standards.iteh.ai/catalog/standards/sist/23c2ef4c-e7ba-4e4d-9c00-fec292cd1601/iso-8336-1993>

fec292cd1601/iso-8336-1993

© ISO 1993

All rights reserved. No part of this publication may be reproduced or utilized in any form or by any means, electronic or mechanical, including photocopying and microfilm, without permission in writing from the publisher.

International Organization for Standardization

Case Postale 56 • CH-1211 Genève 20 • Switzerland

Printed in Switzerland

<b>10.1</b>	Conformity with requirements .....	<b>11</b>
<b>10.2</b>	Evidence of conformity of consignment of finished products .....	<b>11</b>

**Annexes**

<b>A</b>	Receiving inspection for products which are not subject to third-party certification .....	<b>12</b>
<b>B</b>	Systems tests .....	<b>13</b>

**iTeh STANDARD PREVIEW**  
**(standards.iteh.ai)**

[ISO 8336:1993](https://standards.iteh.ai/catalog/standards/sist/23c2ef4c-e7ba-4e4d-9c00-fec292cd1601/iso-8336-1993)

<https://standards.iteh.ai/catalog/standards/sist/23c2ef4c-e7ba-4e4d-9c00-fec292cd1601/iso-8336-1993>

## Foreword

ISO (the International Organization for Standardization) is a worldwide federation of national standards bodies (ISO member bodies). The work of preparing International Standards is normally carried out through ISO technical committees. Each member body interested in a subject for which a technical committee has been established has the right to be represented on that committee. International organizations, governmental and non-governmental, in liaison with ISO, also take part in the work. ISO collaborates closely with the International Electrotechnical Commission (IEC) on all matters of electrotechnical standardization.

Draft International Standards adopted by the technical committees are circulated to the member bodies for voting. Publication as an International Standard requires approval by at least 75 % of the member bodies casting a vote.

International Standard ISO 8336 was prepared by Technical Committee ISO/TC 77, *Products in fibre reinforced cement*.

Annex A forms an integral part of this International Standard. Annex B is for information only.

IEH STANDARD PREVIEW

(standards.iteh.ai)

ISO 8336:1993

<https://standards.iteh.ai/catalog/standards/sst/23c2ef4c-e7ba-4e4d-9c00-fec292cd1601/iso-8336-1993>

# Fibre-cement flat sheets

## 1 Scope

This International Standard specifies the characteristics and establishes methods of control and test as well as acceptance conditions for fibre-cement flat sheets.

It covers sheets intended for external applications such as cladding façades, curtain walls, soffits, lost casing, etc., and sheets intended for internal use such as partitions, floors, ceilings, etc., with a wide range of properties appropriate to the type of application. These sheets may have either a smooth or textured surface.

This International Standard does not apply to the following products:

- a) boards of Portland or equivalent cement reinforced with fibrous wood particles;
- b) non-combustible fibre-reinforced boards of calcium silicate or cement for insulation and fire protection;
- c) gypsum plasterboard;
- d) asbestos-cement flat sheets;
- e) asbestos-cement slates and siding shingles;
- f) fibre-cement slates and siding shingles.

## 2 Normative references

The following standards contain provisions which, through reference in this text, constitute provisions of this International Standard. At the time of publi-

- 1) National standards may specify the binder to be used.
- 2) For the purposes of this International Standard, fibres include:
  - discrete elements randomly dispersed,
  - continuous strands or tapes,
  - nets and webs.

cation, the editions indicated were valid. All standards are subject to revision, and parties to agreements based on this International Standard are encouraged to investigate the possibility of applying the most recent editions of the standards indicated below. Members of IEC and ISO maintain registers of currently valid International Standards.

ISO 390:1993, *Products in fibre-reinforced cement — Sampling and inspection.*

ISO 2602:1980, *Statistical interpretation of test results — Estimation of the mean — Confidence interval.*

## 3 General composition

Fibre-cement flat sheets consist essentially of an inorganic hydraulic binder<sup>1)</sup> or a calcium silicate binder formed by the chemical reaction of a siliceous material and a calcareous material reinforced by organic fibres and/or inorganic synthetic fibres.<sup>2)</sup>

Process aids, fillers and pigments which are compatible with fibre-reinforced cement may be added.

## 4 Classification

Flat sheets covered by this International Standard are divided into two types.

### 4.1 Type A

Type A sheets are intended for external applications where they may be subjected to the direct action of sun, rain and/or snow. They may be supplied coated

or uncoated. Type A sheets shall comply with the requirements of the type-tests in clause 6.

The sheets are further classified into three categories according to their modulus of rupture.

The manufacturer shall declare the type and category of his product in his literature.

## 4.2 Type B

Type B sheets are not subjected to the type-tests and are intended for internal applications and external applications where they will not be subjected to the direct action of sun, rain and/or snow.

The sheets are further classified into five categories according to their modulus of rupture.

The manufacturer shall declare the type and category of his product in his literature.

NOTE 1 If sheets of type B are used in external applications where they are directly exposed to the weather but are protected (e.g. coating or impregnation), the weather resistance of the product is determined by the quality of the protection. Specification of this protection and methods for control and test are outside the scope of this International Standard.

## 5 Acceptance characteristics

### 5.1 Dimensional and geometrical characteristics

#### 5.1.1 Nominal length and width

5.1.1.1 Flat fibre-cement sheets are normally available in nominal lengths up to 3 000 mm and nominal widths up to 1 250 mm. Sheets of greater nominal lengths and widths may be supplied.

5.1.1.2 Preferred nominal dimensions for length and width may be specified in national standards taking into account that the dimensions of the sheets are determined largely by the purpose for which they are intended.

NOTE 2 The nominal dimensions (width and length) specified in national standards may be increased by 20 mm to 30 mm (oversize sheets) for application where the sheet is required to be cut by the user.

#### 5.1.2 Thickness

Flat fibre-cement sheets are normally available in thicknesses from 3 mm to 30 mm, although thicknesses outside this range may be supplied. Preferred thicknesses may be specified in national standards.

3) When sampling from continuous production, testing of the base sheet prior to coating is acceptable where it can be shown that there is a correlation between the results of tests on sheets with and without the coating.

### 5.1.3 Tolerances on dimensions

Tolerances on nominal dimensions are as follows:

a) on length and width (indicated by  $d$ ):

$d \leq 1\,000$  mm:  $\pm 5$  mm

$1\,000$  mm  $< d \leq 1\,600$  mm:  $\pm 0,5$  %

$d > 1\,600$  mm:  $\pm 8$  mm

These tolerances do not apply to oversize sheets.

The measurement method is given in 8.1.1.2.

b) on thickness,  $e$ :

$e \leq 6$  mm:  $\pm 0,6$  mm

$e > 6$  mm:  $\pm 10$  %

For sheets without texture on the exposed face the maximum difference between extreme values of the thickness measurements within one sheet shall not exceed 15 % of the maximum measured value.

The measurement method is given in 8.1.1.3.

NOTE 3 Tighter tolerances may be adopted by agreement between the manufacturer and the purchaser.

### 5.1.4 Tolerances on shape

#### 5.1.4.1 Straightness of edges

The tolerance on the straightness of edges is 3 mm/m for the relevant dimension (length or width). The measurement method is given in 8.1.1.4.

#### 5.1.4.2 Squareness of edges

The tolerance on squareness of sheets is 4 mm/m. The measurement method is given in 8.1.1.5.

NOTE 4 Tighter tolerances may be adopted by agreement between the manufacturer and the purchaser.

## 5.2 Mechanical and physical characteristics

Where the product is supplied coated, the following mechanical and physical specifications apply to the coated (i.e. finished) product.<sup>3)</sup>

### 5.2.1 Bending strength

When tested as specified in 8.1.2.1, the minimum modulus of rupture of the sheets, expressed in megapascals, shall be as specified in table 1. The modulus of rupture shall be the average of the values obtained from testing the samples in both directions.

Type A sheet strengths shall only be specified in the wet condition and the specimens shall be tested in the wet condition.

Type B sheet strengths shall only be specified in the equilibrium condition and the specimens shall be tested in the equilibrium condition.<sup>4)</sup>

NOTE 5 If the manufacturer includes product strengths in his literature, it should be clearly stated whether they are mean or minimum values and they should be determined using the methods specified in 8.1.2.1. The minimum values are based on the same sampling and inspection procedures as for classification in table 1.

**Table 1 — Minimum modulus of rupture**

Values in megapascals

Category	Minimum MOR	
	Type A sheets	Type B sheets
1	—	4
2	—	7
3	7	10
4	13	16
5	18	22

### 5.2.2 Apparent density

The manufacturer shall specify in his literature the minimum apparent density for each category of sheet and when tested in accordance with the method specified in 8.1.2.2, the density shall be not less than this value.

### 5.2.3 Other characteristics

The manufacturer shall provide such technical data as is necessary to confirm the suitability of the product for any particular recommended application.

## 6 Type characteristics

This clause applies to type A sheets only.

These tests shall be carried out on products as delivered. Where the tests are carried out on coated products, this shall be stated in the report.

### 6.1 Bending strength

When tested as specified in 8.2.1, in equilibrium and wet conditions, the average modulus of rupture of each individual piece of the finished products shall not

be less than the values for the appropriate category specified in table 1.

In addition the mean modulus of rupture under wet conditions shall be not less than 50 % of the mean modulus of rupture under equilibrium conditions.

### 6.2 Water permeability

When tested as specified in 8.2.2, traces of moisture may appear on the underside of the sheet, but in no instance shall there be formation of drops of water.

### 6.3 Frost resistance<sup>5)</sup>

If local climatic conditions justify or if national standards specify the freeze-thaw test, the specimen shall comply with the following requirements.

When sheets are tested as specified in 8.2.3, after 50 freeze-thaw cycles, the limit  $L_1$  of the average ratio  $\bar{r}$ , as defined in 8.2.3.4, shall not be less than 0,75.

### 6.4 Warm water<sup>5)</sup>

If national standards specify a warm water test according to 8.2.4, the specimen shall comply with the following requirements.

When sheets are tested as specified in 8.2.4, the limit  $L_1$  of the average ratio  $\bar{r}$ , as defined in 8.2.5.4, shall be greater than 0,75.

### 6.5 Heat-rain<sup>5)</sup>

This test is carried out on the finished product.

When sheets are tested as specified in B.5, any visible cracks, delamination or other defects in the sheets shall not be of a degree such as to affect their performance in use.

### 6.6 Soak-dry

When sheets are tested as specified in 8.2.5, the limit  $L_1$  of the average ratio  $\bar{r}$ , as defined in 8.2.5.4 shall be greater than 0,75.

## 7 Tests

### 7.1 Acceptance tests

The objective of an acceptance test is to establish whether a batch of products conforms to a specification. The tests shall be performed on samples drawn either from continuous production or from a consignment. (See also clause 10.)

4) When sampling from continuous production, these tests may be conducted on dry or saturated specimens provided a relationship can be established between the equilibrium values and the dry or saturated values.

5) These requirements do not apply to surface coatings.

The acceptance tests shall be carried out at the manufacturer's works on sheets and test specimens cut from sheets as delivered.

The following acceptance tests shall be carried out:

- a) dimensional and geometrical characteristics (compulsory), see 8.1.1;
- b) bending strength (compulsory), see 8.1.2.1;
- c) density (compulsory), see 8.1.2.2.

## 7.2 Type-tests

A type-test is concerned with the approval of a new product and/or a fundamental change in formulation and/or method of manufacture, the effects of which cannot be predicted on the basis of former experience.

The test shall be performed on the as-delivered product.

The test is required to demonstrate conformity of a generic product to a specification but is not required for each production batch.

When type-tests are carried out, the product shall also be subjected to the acceptance tests to ensure that it complies with the requirements of this International Standard.

The following type-tests shall be carried out:

- a) bending strength (compulsory), see 6.1;
- b) water permeability (compulsory), see 6.2;
- c) freeze-thaw (optional), see 6.3;
- d) warm water (optional), see 6.4;
- e) soak-dry (compulsory), see 6.6.

## 7.3 Systems tests

The heat-rain test (optional) should be carried out in accordance with annex B.

## 8 Test methods

### 8.1 Acceptance tests

#### 8.1.1 Geometrical tests

##### 8.1.1.1 Apparatus

- a) Smooth, flat, rigid inspection surface of production quality and of dimensions appropriate to the dimensions of the sheets.

Two metal rules shall be fixed at right angles along adjacent edges of the inspection surface. The straightness of each metal rule shall be at least 0,3 mm/m and the right angle shall be accurate to at least 0,1 % (less than 1 mm deviation from normal per metre of length) or 0,001 rad.

Alternatively a portable square may be used. The same requirements for straightness and angularity apply.

- b) Suitable metal rulers, capable of being read to 0,5 mm.
- c) Dial gauge, reading at least to 0,05 mm, with flat parallel metal jaws, between 10 mm and 15 mm in diameter.

#### 8.1.1.2 Measurement of width and length

For each dimension, carry out three measurements, i.e. one in the middle and one at approximately 50 mm from either end. Avoid taking the measurement over a local deformation which could be considered as a visual defect.

Smooth any rough areas.

Take each reading to the nearest 0,5 mm.

Report the individual results. Assess the results against the tolerances given in 5.1.3.

#### 8.1.1.3 Measurement of thickness

Carry out three measurements across the width at one end of the smooth or textured sheet with the dial gauge as indicated in figure 1. Take each reading to an accuracy of 0,05 mm.

Report the individual results. Calculate the arithmetic mean and difference between extreme values. Assess the results against the tolerances given in 5.1.3.

NOTE 6 If the face texture does not allow a sufficiently accurate measurement of the thickness, the thickness of face-textured products is determined from volume measurement by water displacement where the test piece has been saturated before measurement. The thickness is given by the formula

$$e = \frac{V}{lb}$$

where

- e* is the average thickness of the test piece;
- V* is the volume determined by water displacement;
- l* is the specimen length;
- b* is the specimen width.

Alternative methods for determination of the average thickness of textured specimens may be used provided they can



be proven, on average, to yield a thickness measurement within  $\pm 2\%$  of that determined from volume measurement by water displacement.

#### 8.1.1.4 Measurement of straightness of edges

Apply each of the edges to the relevant arm of the square.

Measure to the nearest 0,5 mm, by means of a steel rule, the greatest separation between the edge of the sheet and the arm of the square. Report the results.

Assess each result against the tolerance given in 5.1.4.1.

#### 8.1.1.5 Measurement of out-of-squareness of sheet

Place each of the four corners of the sheet in succession between the arms of the square, keeping one side against the full length of the large arm and the other side in contact with the small arm.

In this position, measure to the nearest 0,5 mm the greatest distance of the sheet edge from the small arm of the square.

Report each result. Assess the results against the tolerances given in 5.1.4.2.

## 8.1.2 Mechanical and physical tests

### 8.1.2.1 Bending strength

#### 8.1.2.1.1 Shapes and dimensions of test pieces

The test specimens shall be of the following shapes:

- for sheets of thicknesses  $e \leq 9$  mm: two square specimens per sheet;
- for sheets of thicknesses  $e > 20$  mm: four rectangular specimens per sheet;
- for sheet thicknesses in the range  $9 \text{ mm} < e \leq 20$  mm, the test specimens may be either square or rectangular.

Dimensions of the test specimens are specified in table 2.

#### 8.1.2.1.2 Cutting specimens

The test specimens shall be cut from the same part of the sheet. One possible layout is shown in figure 2 (the distance of 200 mm is indicative). Other cutting layouts may be used provided that an equal number of specimens are cut perpendicular and parallel to the manufacturing direction.

iTeh STANDARD PREVIEW  
(standards.iteh.ai)

ISO 8336:1993

<https://standards.iteh.ai/catalog/standards/sist/23c2ef4c-e7ba-4e4d-9c00-fec292cd1601/iso-8336-1993>

Dimensions in millimetres

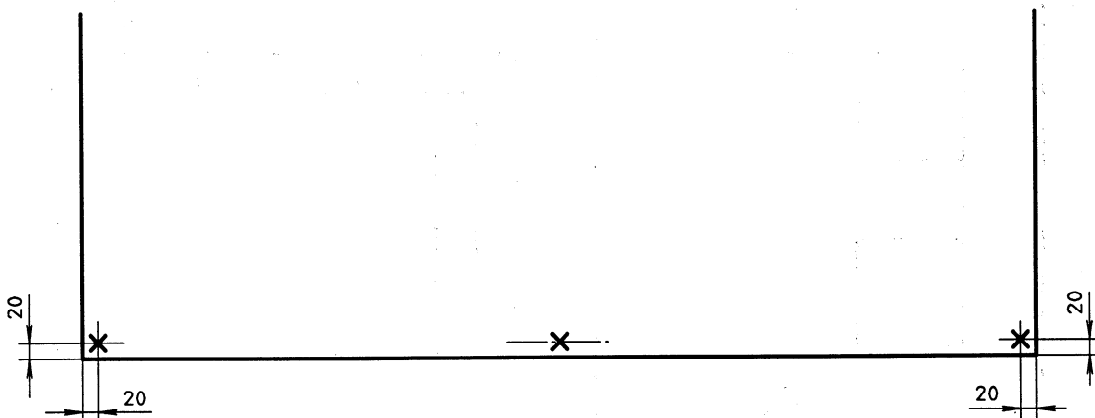

Figure 1 — Measurement of thickness

**Table 2 — Specimen dimensions**

Dimensions in millimetres

Specimen shape	Dimensions of test specimen	
	Length	Width
Square	250	250
Rectangular	Test span + 40 <sup>1)</sup>	100 min.

1) The distance between supports may be reduced for narrow products where full size specimens cannot be obtained provided the distance is not less than  $18e$  where  $e$  is the thickness of the specimen, in millimetres.

**8.1.2.1.3 Conditioning for equilibrium strength**

Place the test specimens for 7 days in a controlled atmosphere of  $23\text{ °C} \pm 5\text{ °C}$  and  $(50 \pm 10)\%$  relative humidity, and in such a manner that all faces are adequately ventilated.

**8.1.2.1.4 Conditioning for wet strength** (standards.iteh.ai)

Immerse the test specimens in water at a minimum temperature of  $5\text{ °C}$  for 24 h.

For nominal thicknesses greater than 20 mm, the conditioning period shall be 48 h.

The test specimens shall be tested immediately upon removal from the water.

**8.1.2.1.5 Apparatus**

The apparatus includes the following items:

a) Bending test machine (see figure 3) with a constant rate of deflection when applying the load (where this facility is not available, a constant rate of loading is acceptable) and with an error of accuracy and an error of reproducibility equal to or less than 3 %, comprising:

1) two parallel supports, one rigid and one self-aligning, the distance between the supports,  $a$ , being a function of the thickness of the test piece (see table 3). The upper faces of the supports shall be rounded and shall have a radius  $r$  between 3 mm (minimum) and 25 mm (maximum);

2) a loading bar identical to the two supports shall be situated above the specimen so that it is parallel to the supports and at an equal distance from each.

b) A micrometer reading to at least 0,05 mm with flat parallel metal jaws between 10 mm and 15 mm in diameter.

**STANDARD PREVIEW**  
<https://standards.iteh.ai/catalog/standards/sist/25c2c4c-e7ba-4e4d-9c00-fec292cd1601/iso-8336-1993>

Dimensions in millimetres

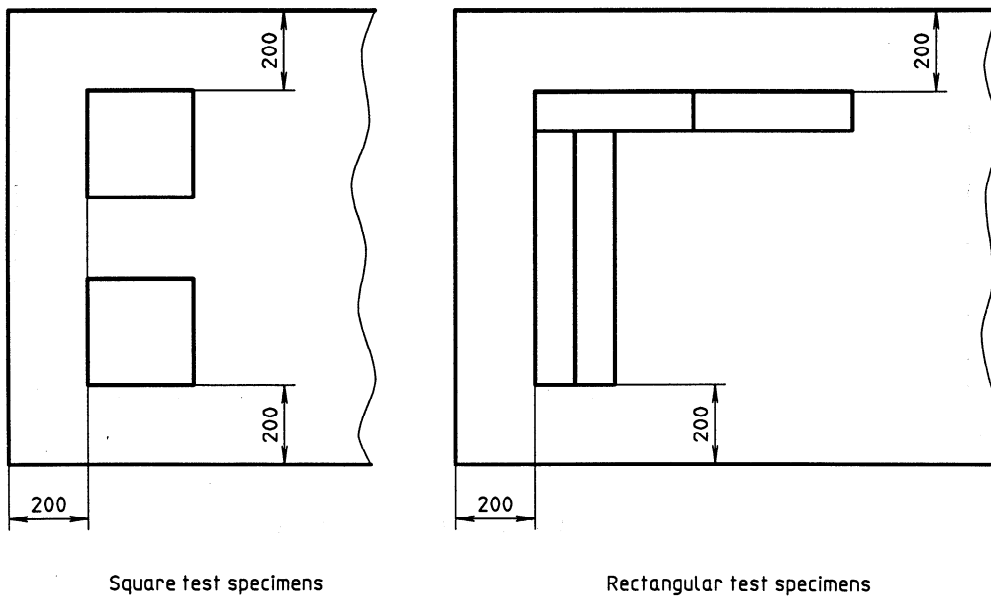

**Figure 2 — Cutting of test specimens**

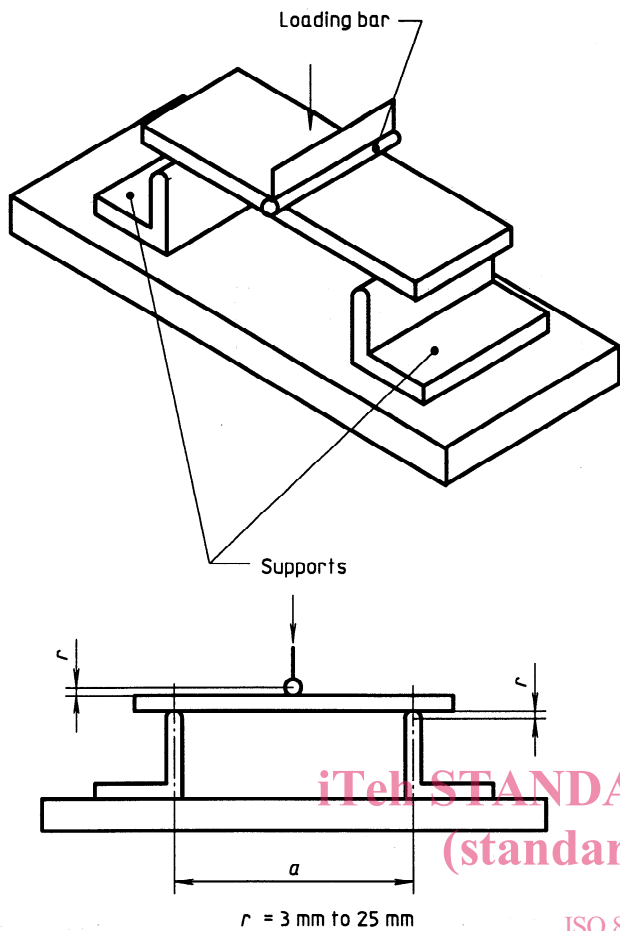

Figure 3 — Bending test machine layout

8.1.2.1.6 Procedure

Arrange the test piece with the underside against the supports and load the test piece along its centreline by means of the loading bar.

Load the specimen such that breakage occurs within 10 s to 30 s. A constant rate of deflection is preferred. Where this facility is not available a regular rate of loading is acceptable.

Measure the thickness at two points for smooth specimens and four points for textural specimens along the section of breakage as indicated in figure 4.

For square test specimens, re-assemble the broken pieces.

Submit the re-assembled test specimens to a second bending test with the line of load application at right angles to that of the first test. Measure the thickness of the test piece at two points for smooth sheets or four points for textured sheets along the new section of breakage as indicated in figure 4.

Where rectangular test specimens are used, the strengths in the two directions are obtained by testing each of the appropriate specimens (see figure 4).

8.1.2.1.7 Expression and interpretation of results

The modulus of rupture,  $R_f$ , in megapascals, is given by the formula

$$R_f = \frac{3Pl}{2be^2}$$

where

- $P$  is the breaking load, in newtons;
- $l$  is the distance between axes of supports, in millimetres;
- $b$  is the width of the test piece, in millimetres;
- $e$  is the average thickness of the test piece (arithmetic average of two measurements for smooth and four measurements for textured), in millimetres.

The modulus of rupture of the sheet shall be the arithmetic mean of the four values (two values in each direction).

Assess the results against the specifications of 5.2.2.

Table 3 — Distance between supports (test span)

Dimensions in millimetres

Test specimen	Distance between axes of supports, $a$ 1)
Square	215
Rectangular	$18e$ min.
NOTE — For square specimens other distances between supports may be used provided compatibility can be demonstrated between results obtained with the different test spans and results obtained with the standard spans.	
1) The distance between the axes of the supports may be reduced for narrow products, where full size specimens cannot be obtained, provided the distance is not less than $18e$ where $e$ is the thickness of the specimen, in millimetres.	