

INTERNATIONAL STANDARD

ISO
8362-6

First edition
1992-10-01

Injection containers for injectables and accessories —

Part 6:

**Caps made of aluminium-plastics combinations
for injection vials**

<https://standards.iteh.ai/catalog/standards/siv/59743571417370c5845e2iso-8362-6-1992>

Réipients et accessoires pour produits injectables —

*Partie 6. Capsules en combinaison aluminium-plastique pour flacons
d'injection*



Reference number
ISO 8362-6:1992(E)

Contents

	Page
1 Scope	1
2 Normative references	1
3 Classification of types	1
4 Dimensions and tolerances	1
5 Designation	2
6 Requirements	2
7 Packaging	3
8 Marking	3

iTeh STANDARD PREVIEW (standards.iteh.ai)

ISO 8362-6:1992

<https://standards.iteh.ai/catalog/standards/sist/c3b58fd3-8590-43c7-a311-737a0c5845e2/iso-8362-6-1992>

© ISO 1992

All rights reserved. No part of this publication may be reproduced or utilized in any form or by any means, electronic or mechanical, including photocopying and microfilm, without permission in writing from the publisher.

International Organization for Standardization
Case Postale 56 • CH-1211 Genève 20 • Switzerland

Printed in Switzerland

Foreword

ISO (the International Organization for Standardization) is a worldwide federation of national standards bodies (ISO member bodies). The work of preparing International Standards is normally carried out through ISO technical committees. Each member body interested in a subject for which a technical committee has been established has the right to be represented on that committee. International organizations, governmental and non-governmental, in liaison with ISO, also take part in the work. ISO collaborates closely with the International Electrotechnical Commission (IEC) on all matters of electrotechnical standardization.

Draft International Standards adopted by the technical committees are circulated to the member bodies for voting. Publication as an International Standard requires approval by at least 75 % of the member bodies casting a vote.

International Standard ISO 8362-6 was prepared by Technical Committee ISO/TC 76, *Transfusion, infusion and injection equipment for medical use*.

ISO 8362 consists of the following parts, under the general title *Injection containers for injectables and accessories*:

- Part 1: *Injection vials made of glass tubing*
- Part 2: *Closures for injection vials*
- Part 3: *Aluminium caps for injection vials*
- Part 4: *Injection vials made of moulded glass*
- Part 5: *Freeze drying closures for injection vials*
- Part 6: *Caps made of aluminium-plastics combinations for injection vials*
- Part 7: *Injection caps made of aluminium-plastics combinations without overlapping plastics part*

Introduction

The materials from which injection containers (including elastomeric closures) are made are suitable primary packaging materials for storing injectable products until they are administered. However, in this part of ISO 8362, caps are not considered as primary packaging materials in direct contact with pharmaceutical preparations.

iTeh STANDARD PREVIEW (standards.iteh.ai)

ISO 8362-6:1992

<https://standards.iteh.ai/catalog/standards/sist/c3b58fd3-8590-43c7-a311-737a0c5845e2/iso-8362-6-1992>

Injection containers for injectables and accessories —

Part 6:

Caps made of aluminium-plastics combinations for injection vials

1 Scope

This part of ISO 8362 specifies caps made of aluminium-plastics combinations for injection vials as specified in ISO 8362-1 and ISO 8362-4.

ISO 8362-4:1989, *Injection containers for injectables and accessories — Part 4: Injection vials made of moulded glass.*

ISO 8872:1988, *Aluminium caps for transfusion, infusion and injection bottles — General requirements and test methods.*

ISO 10985:1992, *Caps made of aluminium-plastics combinations for infusion bottles and injection vials — Requirements and test methods.*

2 Normative references

The following standards contain provisions which, through reference in this text, constitute provisions of this part of ISO 8362. At the time of publication, the editions indicated were valid. All standards are subject to revision, and parties to agreements based on this part of ISO 8362 are encouraged to investigate the possibility of applying the most recent editions of the standards indicated below. Members of IEC and ISO maintain registers of currently valid International Standards.

ISO 2768-1:1989, *General tolerances — Part 1: Tolerances for linear and angular dimensions without individual tolerance indications.*

ISO 2768-2:1989, *General tolerances — Part 2: Geometrical tolerances for features without individual tolerance indications.*

ISO 8362-1:1989, *Injection containers for injectables and accessories — Part 1: Injection vials made of glass tubing.*

ISO 8362-3:1989, *Injection containers for injectables and accessories — Part 3: Aluminium caps for injection vials.*

iTeh STANDARD PREVIEW
(standards.iteh.ai)

ISO 8362-6:1992

<https://standards.iteh.ai/catalog/standards/sist/c3b58fd3-8590-43c7-a311-77760e1479/iso-8362-6-1992>

3 Classification of types

Caps shall be classified as follows:

- Type ZB: Aluminium cap with central opening, and plastics component;
- Type ZD: Aluminium cap with complete tear-off tab, and plastics component.

4 Dimensions and tolerances

4.1 Dimensions

All cover versions (flat, ring-shaped or others) of caps shall meet the dimensions given in figure 1 and table 1.

NOTE 1 The configuration of the cap shown in figure 1 is informative only.

4.2 Tolerances

The tolerances shall be in accordance with ISO 2768-1 and ISO 2768-2.

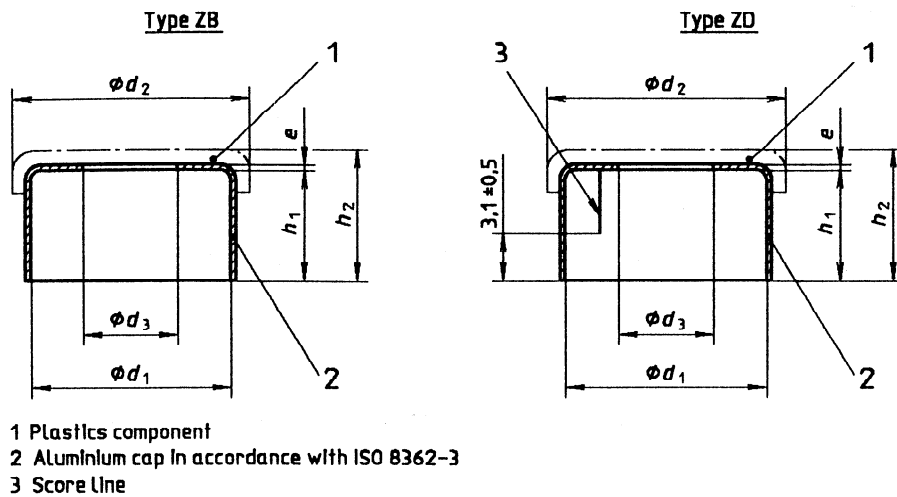

Figure 1 — Configuration of cap

Table 1 — Dimensions of cap

Nominal size	d_1 +0,1 0	d_2 ¹⁾		d_3 ²⁾		e ³⁾		h_1 ± 0,2	h_2 ⁴⁾	
		min.	max.	min.	max.	min.	max.		min.	max.
13	13,3	15	16	3	8	0,168	0,242	6,3	7,3	8,4
20	20,3	22,2	23,2	6	10			7,3	8,7	9,8

1) The diameter d_2 shall be agreed between the manufacturer and user. It shall not differ from the nominal value by more than ± 0,25 mm. The extreme limits are given without tolerance.
 2) After plastics element removal.
 3) The thickness e shall be agreed between the manufacturer and user. It shall not differ from the nominal value by more than ± 0,022 mm. The extreme limits are given without tolerance.
 4) The height h_2 shall be agreed between the manufacturer and user. It shall not differ from the nominal value by more than ± 0,3 mm. The extreme limits are given without tolerance.

5 Designation

Aluminium-plastics caps shall be designated according to type: the designation shall be expressed as the word "cap", the number and part of this International Standard followed by the type letters, followed by the nominal size of the container.

For example a type ZD aluminium-plastics cap of nominal size 13 complying with the requirements laid down in this part of ISO 8362 is designated:

Cap ISO 8362-6 - ZD - 13

6 Requirements

6.1 General requirements

6.1.1 The requirements for aluminium caps shall be in accordance with ISO 8362-3.

6.1.2 The requirements for plastics components, and the combination between the plastics component and the aluminium cap, shall be in accordance with ISO 10985.

6.1.3 Construction elements which penetrate into the interior space of the aluminium cap shall not interfere with the sealing process.

6.2 Forces required to remove tab

6.2.1 The maximum forces required to remove the tab shall comply with table 2.

Table 2 — Forces required to remove plastics component and tear off tab completely

Forces in newtons

Nominal size	Force to remove plastics component max.	Force to tear off tab completely max.
13	25	30
20	35	40

6.2.2 For incoming control, a minimum value for the tear-off tab removal force shall be agreed between the supplier and user. The injection caps shall also withstand a sterilization process in accordance with ISO 8872:1988, subclauses 5.1 and 5.2 b).

7 Packaging

Packaging shall comply with the requirements of ISO 8872.

8 Marking

Marking shall be in accordance with ISO 8872 and the designation shall be as specified in clause 5.

iTeh STANDARD PREVIEW
(standards.iteh.ai)

ISO 8362-6:1992

<https://standards.iteh.ai/catalog/standards/sist/c3b58fd3-8590-43c7-a311-737a0c5845e2/iso-8362-6-1992>

iTeh STANDARD PREVIEW
(standards.iteh.ai)

ISO 8362-6:1992

<https://standards.iteh.ai/catalog/standards/sist/c3b58fd3-8590-43c7-a311-737a0c5845e2/iso-8362-6-1992>

UDC 615.473:615.456.014.87-[034 + 036]

Descriptors: medical equipment, parenteral infusion equipment, containers, bottles, aluminium products, plastics products, caps (containers), classification, specifications, dimensions, designation, marking, packaging.

Price based on 3 pages
