

---

---

**Kabelska omrežja za televizijske in zvokovne signale ter interaktivne storitve –  
7-2. del: Nadzorovanje stanja zunanjih inštalacij omrežij hibridnih optično-  
koaksialnih kablov – Specifikacija plasti za dostop do medijev (MAC) (IEC  
60728-7-2:2003)**

**(istoveten EN 60728-7-2:2005)**

Cable networks for television signals, sound signals and interactive services – Part  
7-2: Hybrid Fibre Coax Outside Plant Status Monitoring – Media access Control  
(MAC) Layer Specification (IEC 60728-7-2:2003)

[SIST EN 60728-7-2:2006](https://standards.iteh.ai/catalog/standards/sist/a9dab8ab-8c36-407a-a800-507de774bb78/sist-en-60728-7-2-2006)

[https://standards.iteh.ai/catalog/standards/sist/a9dab8ab-8c36-407a-a800-  
507de774bb78/sist-en-60728-7-2-2006](https://standards.iteh.ai/catalog/standards/sist/a9dab8ab-8c36-407a-a800-507de774bb78/sist-en-60728-7-2-2006)

**iTeh STANDARD PREVIEW**  
**(standards.iteh.ai)**

SIST EN 60728-7-2:2006

<https://standards.iteh.ai/catalog/standards/sist/a9dab8ab-8c36-407a-a800-507de774bb78/sist-en-60728-7-2-2006>

English version

**Cable networks for television signals,  
sound signals and interactive services  
Part 7-2: Hybrid Fibre Coax Outside Plant Status Monitoring –  
Media access Control (MAC) Layer Specification  
(IEC 60728-7-2:2003)**

Réseaux de distribution par câbles  
pour signaux de télévision, signaux  
de radiodiffusion sonore et services  
interactifs

Partie 7-2: Surveillance de l'état  
des installations extérieures des réseaux  
hybrides à fibre optique et câble coaxial –  
Spécification de la couche du contrôle  
d'accès au support  
(CEI 60728-7-2:2003)

Kabelnetze für Fernsehsignale,  
Tonsignale und interaktive Dienste  
Teil 7-2: Zustandsüberwachung Hybrid-  
Faser-Koax-Netze (HFC) –  
Festlegung Steuerungsschicht  
für Mediumzugriff (MAC)  
(IEC 60728-7-2:2003)

[SIST EN 60728-7-2:2006](https://standards.iteh.ai/catalog/standards/sist/a9dab8ab-8c36-407a-a800-507de774bb78/sist-en-60728-7-2-2006)

This European Standard was approved by CENELEC on 2004-12-01. CENELEC members are bound to comply with the CEN/CENELEC Internal Regulations which stipulate the conditions for giving this European Standard the status of a national standard without any alteration.

Up-to-date lists and bibliographical references concerning such national standards may be obtained on application to the Central Secretariat or to any CENELEC member.

This European Standard exists in one official version (English). A version in any other language made by translation under the responsibility of a CENELEC member into its own language and notified to the Central Secretariat has the same status as the official versions.

CENELEC members are the national electrotechnical committees of Austria, Belgium, Cyprus, Czech Republic, Denmark, Estonia, Finland, France, Germany, Greece, Hungary, Iceland, Ireland, Italy, Latvia, Lithuania, Luxembourg, Malta, Netherlands, Norway, Poland, Portugal, Slovakia, Slovenia, Spain, Sweden, Switzerland and United Kingdom.

## CENELEC

European Committee for Electrotechnical Standardization  
Comité Européen de Normalisation Electrotechnique  
Europäisches Komitee für Elektrotechnische Normung

**Central Secretariat: rue de Stassart 35, B - 1050 Brussels**

## Foreword

The text of the International Standard IEC 60728-7-2:2003, prepared by technical area 5: Cable networks for television signals, sound signals and interactive services, of IEC TC 100, Audio, video and multimedia systems and equipment, was submitted to the formal vote and was approved by CENELEC as EN 60728-7-2 on 2004-12-01 without any modification.

The following dates were fixed:

- latest date by which the EN has to be implemented at national level by publication of an identical national standard or by endorsement (dop) 2005-12-01
- latest date by which the national standards conflicting with the EN have to be withdrawn (dow) 2007-12-01

---

## Endorsement notice

The text of the International Standard IEC 60728-7-2:2003 was approved by CENELEC as a European Standard without any modification.

**iTeh STANDARD PREVIEW**  
**(standards.iteh.ai)**

SIST EN 60728-7-2:2006

<https://standards.iteh.ai/catalog/standards/sist/a9dab8ab-8c36-407a-a800-507de774bb78/sist-en-60728-7-2-2006>

# INTERNATIONAL STANDARD

# IEC 60728-7-2

First edition  
2003-10

---

---

## Cable networks for television signals, sound signals and interactive services –

### Part 7-2: Hybrid Fibre Coax Outside Plant Status Monitoring – Media access Control (MAC) Layer Specification

<https://standards.iteh.ai/catalog/standards/sist/a9dab8ab-8c36-407a-a800-507de774bb78/sist-en-60728-7-2-2006>

© IEC 2003 — Copyright - all rights reserved

No part of this publication may be reproduced or utilized in any form or by any means, electronic or mechanical, including photocopying and microfilm, without permission in writing from the publisher.

International Electrotechnical Commission, 3, rue de Varembe, PO Box 131, CH-1211 Geneva 20, Switzerland  
Telephone: +41 22 919 02 11 Telefax: +41 22 919 03 00 E-mail: [inmail@iec.ch](mailto:inmail@iec.ch) Web: [www.iec.ch](http://www.iec.ch)



Commission Electrotechnique Internationale  
International Electrotechnical Commission  
Международная Электротехническая Комиссия

PRICE CODE

X

*For price, see current catalogue*

## CONTENTS

FOREWORD .....	4
INTRODUCTION .....	6
1 Scope .....	7
2 Normative references.....	7
3 Terms, definitions and abbreviations.....	8
4 Reference architecture forward and return channel specifications.....	10
5 Media access control layer specification .....	10
5.1 Overview .....	10
5.2 MAC packet transport .....	11
5.3 MAC packet structure .....	13
5.4 MAC packet delimiters .....	18
5.5 MAC protocol data units (PDUs) .....	18
6 MAC protocol operation .....	29
6.1 Non-volatile parameters.....	29
6.2 Duplex capabilities.....	29
6.3 Packet priorities.....	29
6.4 Packet reception.....	29
6.5 NE responses .....	30
6.6 Message sequence numbers and transaction synchronization .....	30
6.7 Solicited messages.....	31
6.8 Autonomous (unsolicited) messages.....	31
6.9 Return channel transmissions.....	35
6.10 MAC state machines.....	35
Annex A (informative) Operational details .....	38
A.1 Introduction.....	38
A.2 Time of day.....	38
A.3 Firmware downloads .....	38
A.4 NE addressing .....	38
A.5 Alarm processing HMS MAC protocol .....	39
A.6 Automatic channel discovery.....	43
A.7 Auto-registration .....	44
A.8 Configuration changes and SNMP trap generation .....	45
Figure 1 – Reference architecture diagram.....	10
Figure 2 – Bit transmission order.....	12
Figure 3 – MAC packet structure .....	13
Figure 4 – MAC header control byte – Bit definition.....	13
Figure 5 – MAC header sequence byte – Bit definition .....	16
Figure 6 – MAC PDU structure .....	18
Figure 7 – STATRESP STATUS byte – Bit definition .....	20
Figure 8 – Return channel transmission permitted.....	35

Figure 9 – Contention state diagram .....	36
Figure 10 – Backoff state diagram .....	37
Figure A.1 – Property MIB usage .....	39
Table 1 – Transponder type classifications .....	7
Table 2 – Generic MAC packet structure .....	13
Table 3 – Protocol field values .....	14
Table 4 – MAC PDUs .....	19
Table 5 – Possible MAC protocol transactions .....	19
Table 6 – NAK PDU format .....	20
Table 7 – ACK PDU format .....	20
Table 8 – STATRQST PDU format .....	20
Table 9 – STATRESP PDU format .....	20
Table 10 – CHNLRQST bit settings .....	21
Table 11 – CNTNRM bit settings .....	21
Table 12 – CNTCUR bit settings .....	21
Table 13 – MAJOR bit settings .....	21
Table 14 – MINOR bit settings .....	22
Table 15 – TALKRQST PDU format .....	22
Table 16 – TALK PDU format .....	23
Table 17 – CONTMODE PDU format .....	23
Table 18 – CONTMODE: MODE settings .....	23
Table 19 – NE message retrieval example .....	24
Table 20 – REG_REQ PDU format .....	25
Table 21 – SET_ADDR PDU format .....	25
Table 22 – REG_END PDU format .....	26
Table 23 – REG_END: STATUS settings .....	26
Table 24 – CHNLDESC PDU format .....	27
Table 25 – INVCMD PDU format .....	28
Table 26 – INVCMD: REASON codes .....	28
Table 27 – TIME PDU format .....	29
Table 28 – Non-volatile parameters .....	29
Table 29 – MAC sequence field example (non-contention mode) .....	31
Table 30 – Contention state settings versus forward channel packets .....	32
Table 31 – Backoff state machine parameters .....	34
Table A.1 – Properties .....	40
Table A.2 – Alarm notification and retrieval – Polled mode .....	42
Table A.3 – Alarm notification and retrieval – Contention mode .....	43
Table A.4 – Auto-registration implementation example .....	45

INTERNATIONAL ELECTROTECHNICAL COMMISSION

**CABLE NETWORKS FOR TELEVISION SIGNALS,  
SOUND SIGNALS AND INTERACTIVE SERVICES –**

**Part 7-2: Hybrid Fibre Coax Outside Plant status monitoring –  
Media Access Control (MAC) layer specification**

FOREWORD

- 1) The International Electrotechnical Commission (IEC) is a worldwide organization for standardization comprising all national electrotechnical committees (IEC National Committees). The object of IEC is to promote international co-operation on all questions concerning standardization in the electrical and electronic fields. To this end and in addition to other activities, IEC publishes International Standards, Technical Specifications, Technical Reports, Publicly Available Specifications (PAS) and Guides (hereafter referred to as "IEC Publication(s)"). Their preparation is entrusted to technical committees; any IEC National Committee interested in the subject dealt with may participate in this preparatory work. International, governmental and non-governmental organizations liaising with the IEC also participate in this preparation. IEC collaborates closely with the International Organization for Standardization (ISO) in accordance with conditions determined by agreement between the two organizations.
- 2) The formal decisions or agreements of IEC on technical matters express, as nearly as possible, an international consensus of opinion on the relevant subjects since each technical committee has representation from all interested IEC National Committees.
- 3) IEC Publications have the form of recommendations for international use and are accepted by IEC National Committees in that sense. While all reasonable efforts are made to ensure that the technical content of IEC Publications is accurate, IEC cannot be held responsible for the way in which they are used or for any misinterpretation by any end user.
- 4) In order to promote international uniformity, IEC National Committees undertake to apply IEC Publications transparently to the maximum extent possible in their national and regional publications. Any divergence between any IEC Publication and the corresponding national or regional publication shall be clearly indicated in the latter.
- 5) IEC provides no marking procedure to indicate its approval and cannot be rendered responsible for any equipment declared to be in conformity with an IEC Publication.
- 6) All users should ensure that they have the latest edition of this publication.
- 7) No liability shall attach to IEC or its directors, employees, servants or agents including individual experts and members of its technical committees and IEC National Committees for any personal injury, property damage or other damage of any nature whatsoever, whether direct or indirect, or for costs (including legal fees) and expenses arising out of the publication, use of, or reliance upon, this IEC Publication or any other IEC Publications.
- 8) Attention is drawn to the Normative references cited in this publication. Use of the referenced publications is indispensable for the correct application of this publication.
- 9) Attention is drawn to the possibility that some of the elements of this IEC Publication may be the subject of patent rights. IEC shall not be held responsible for identifying any or all such patent rights.

International Standard IEC 60728-7-2 has been prepared by technical area 5: Cable networks for television signals, sound signals and interactive services, of IEC technical committee 100: Audio, video and multimedia systems and equipment.

This standard was submitted to the national committees for voting under the IEC Fast Track Procedure as the following documents:

CDV	Report on voting
100/577/CDV	100/684/RVC

Full information on the voting for the approval of this standard can be found in the report on voting indicated in the above table.

This publication has been drafted in accordance with the ISO/IEC Directives, Part 2.



The committee has decided that the contents of this publication will remain unchanged until 2006. At this date, the publication will be

- reconfirmed;
- withdrawn;
- replaced by a revised edition, or
- amended.

The following differences exist in some countries:

The Japanese *de facto* standard (NCTEA S-006) concerning requirements for the HFC outside plant management, which was published in 1995, has already been available in Japan. The purpose of this standard is to support the design and implementation of interoperable management systems for HFC cable networks used in Japan.

## iTeh STANDARD PREVIEW (standards.iteh.ai)

SIST EN 60728-7-2:2006

<https://standards.iteh.ai/catalog/standards/sist/a9dab8ab-8c36-407a-a800-507de774bb78/sist-en-60728-7-2-2006>

## INTRODUCTION

Standards of the IEC 60728 series deal with cable networks for television signals, sound signals and interactive services including equipment, systems and installations for

- head-end reception, processing and distribution of television and sound signals and their associated data signals, and
- processing, interfacing and transmitting all kinds of signals for interactive services

using all applicable transmission media.

All kinds of networks like

- CATV-networks,
- MATV-networks and SMATV-networks,
- individual receiving networks,

and all kinds of equipment, systems and installations installed in such networks, are within this scope.

The extent of this standardization work is from the antennas, special signal source inputs to the head-end or other interface points to the network up to the system outlet or the terminal input, where no system outlet exists.

The standardization of any user terminals (i.e. tuners, receivers, decoders, multimedia terminals, etc.) as well as any coaxial and optical cables and accessories therefore is excluded.

[SIST EN 60728-7-2:2006](https://standards.iteh.ai/catalog/standards/sist/a9dab8ab-8c36-407a-a800-507de774bb78/sist-en-60728-7-2-2006)

<https://standards.iteh.ai/catalog/standards/sist/a9dab8ab-8c36-407a-a800-507de774bb78/sist-en-60728-7-2-2006>

## CABLE NETWORKS FOR TELEVISION SIGNALS, SOUND SIGNALS AND INTERACTIVE SERVICES –

### Part 7-2: Hybrid Fibre Coax Outside Plant status monitoring – Media Access Control (MAC) layer specification

#### 1 Scope

This part of IEC 60728 specifies requirements for The Hybrid Fibre Coax (HFC) Outside Plant (OSP) Media Access Control (MAC) Layer. This standard is part of the series developed to support the design and implementation of interoperable management systems for evolving HFC cable networks. The HMS Media Access Control (MAC) layer specification describes the messaging and protocols implemented at the Data Link Layer (DLL), layer 2 in the 7 layer ISO-OSI reference model, that support reliable and efficient communications between HMS compliant transponders interfacing to managed OSP network elements (NEs) and a centralized head-end element (HE).

This standard describes the MAC layer protocols that must be implemented between all *Type 2* and *Type 3* compliant OSP transponders on the HFC plant and the controlling equipment in the head-end to support bandwidth management and reliable communications. Any exceptions to compliance with this standard will be specifically noted herein as necessary. Refer to Table 1 for a full definition of the type classifications.

Transponder type classifications (standardized within the HMS series of standards) are defined in Table 1.

SIST EN 60728-7-2:2006  
**Table 1 – Transponder type classifications**

Type	Description	Application
Type 0	Refers to legacy transponder equipment, which is incapable of supporting the specifications	This transponder interfaces with legacy network equipment through proprietary means.  This transponder could be managed through the same management applications as the other types through proxies or other means at the head-end.
Type 1	Refers to stand-alone transponder equipment (legacy or new), which can be upgraded to support the specifications	This transponder interfaces with legacy network equipment through proprietary means.  Type 1 is a standards-compliant transponder (either manufactured to the standard or upgraded) that connects to legacy network equipment via a proprietary interface.
Type 2	Refers to a stand-alone, compliant transponder	This transponder interfaces with network equipment designed to support the electrical and physical specifications defined in the standards.  It can be factory or field-installed.  Its RF connection is independent of the monitored NE.
Type 3	Refers to a stand-alone or embedded, compliant transponder.	This transponder interfaces with network equipment designed to support the electrical specifications defined in the standards.  It may or may not support the physical specifications defined in the standards.  It can be factory-installed. It may or may not be field-installed.  Its RF connection is through the monitored NE.

#### 2 Normative references

None.

### 3 Terms, definitions and abbreviations

For the purposes of this document, the following definitions apply.

#### 3.1 Terms and definitions

##### 3.2

##### **data link layer (DLL)**

layer 2 in the Open System Interconnection (OSI) architecture; the layer that provides services to transfer data over the physical transmission link between open systems

##### 3.3

##### **forward spectrum**

pass band of frequencies in HFC cable systems with a lower edge of between 48 MHz and 87,5 MHz, depending on the particular geographical area, and an upper edge that is typically in the range of 300 MHz to 860 MHz depending on implementation

##### 3.4

##### **full spectrum**

combined forward and return spectrums in HFC cable systems and excludes any guard band

##### 3.5

##### **guard band**

unused frequency band between the upper edge of the usable return spectrum and the lower edge of the usable forward spectrum in HFC cable systems

##### 3.6

##### **network element (NE)**

active element in the outside plant (OSP) that is capable of receiving commands from a head-end element (HE) in the head-end and, as necessary, providing status information and alarms back to the HE

##### 3.7

##### **open system interconnection (OSI)**

a framework of the International Organization for Standardization (ISO) standards for communication between multi-vendor systems that organizes the communication process into seven different categories that are placed in a layered sequence based on the relationship to the user. Each layer uses the layer immediately below it and provides services to the layer above. Layers 7 through 4 deal with end-to-end communication between the message source and destination, and layers 3 through 1 deal with network functions

##### 3.8

##### **organizationally unique identifier (OUI)**

a 3-octet IEEE assigned identifier that can be used to generate universal LAN MAC addresses and protocol identifiers per ANSI/IEEE standard 802 for use in local and metropolitan area network applications

##### 3.9

##### **physical (PHY) layer**

layer 1 in the open system interconnection (OSI) architecture; the layer that provides services to transmit bits or groups of bits over a transmission link between open systems and which entails electrical, mechanical and handshaking procedures

##### 3.10

##### **return spectrum**

pass band of frequencies in HFC cable systems with a lower edge of 5 MHz and an upper edge that is typically in the range of 42 MHz to 65 MHz depending on the particular geographical area

**3.11****transponder**

device that interfaces to outside plant (OSP) NEs and relays status and alarm information to the HE. It can interface with an active NE via an arrangement of parallel analogue, parallel digital and serial ports

**3.12 Abbreviated terms**

CCITT	Comité Consultatif International de Télégraphie et Téléphonie (ITU – International Telecommunication Union)
CRC	Cyclic Redundancy Code
DLL	Data Link Layer
EMS	Element Management System
FCS	Frame Check Sequence
HE	Head-end Element
HEX	Hexadecimal
HFC	Hybrid Fibre Coax
HMS	Hybrid Management Sub-Layer (defined in the standard)
I/G	Individual / group address bit
IEEE	Institute of Electrical and Electronics Engineers
IP	Internet Protocol
ISO	International Organization for Standardization
LSB	Least Significant Bit
MAC	Media Access Control
MIB	Management Information Base
MSB	Most Significant Bit
NE	Network Element
OSI	Open System Interconnection
OSP	Outside Plant
OUI	Organizationally Unique Identifier
PDU	Protocol Data Unit
PHY	Physical
POSIX	Portable Operating System Interface
RF	Radio Frequency
RFC	Request for Comment
RSVD	Reserved
SNMP	Simple Network Management Protocol
TOD	Time-of-Day
UART	Universal Asynchronous Receiver/Transmitter
UDP	User Datagram Protocol

#### 4 Reference architecture forward and return channel specifications

The reference architecture for the series of specifications is illustrated in Figure 1.

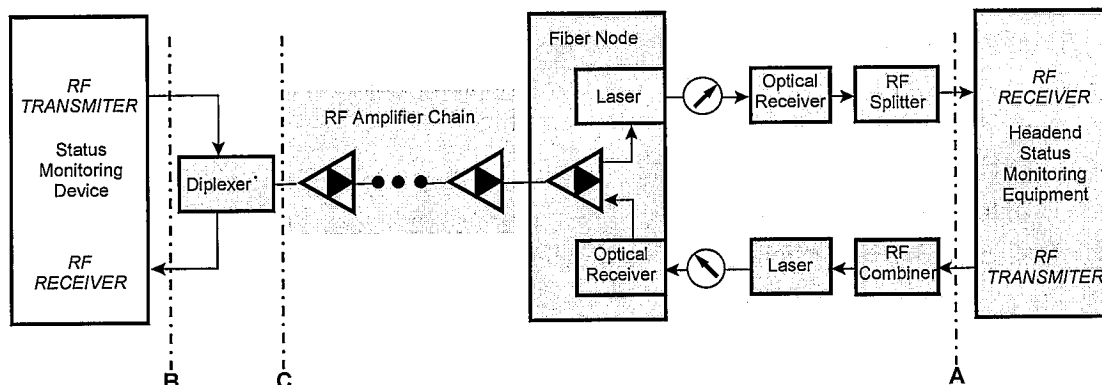

\* The diplexer filter may be included as part of the network element to which the transponder interfaces, or it may be added separately by the network operator.

IEC 2293/03

Figure 1 – Reference architecture diagram

All quantities relating to forward channel transmission or reverse channel reception are measured at point A in Figure 1. All quantities relating to forward channel reception or reverse channel transmission are measured at point B for two-port devices and point C for single-port devices as shown in Figure 1.

#### 5 Media access control layer specification

##### 5.1 Overview

This clause describes the MAC protocol. Some of the MAC protocol features include:

- support for transaction-based message exchange over the HFC forward and return RF channels. Transactions can be initiated by either the HE or the NE; support for transport of multiple network PDU types over the HFC forward and return RF channels including, but not limited to, IP over serial and SNMP over serial;
- extensions provided to support future transport of other network PDU types;
- efficient use of HFC forward and return RF spectrum through central HE management of NE transmission opportunities.

##### 5.1.1 Definitions and conventions

##### 5.1.1.1 Separate forward and return channels

The one-way communication channel from the HE to a managed OSP NE is referred to as the *forward* channel. The one-way communication channel from a managed OSP NE to the HE is referred to as the *return* channel. Both the forward and the return channels are placed on specific centre frequencies. The forward and return channels' centre frequencies are different. Since the NEs only listen to the forward channel, they cannot listen to return channel transmissions from other NEs. This channel separation is a result of the sub-band split between the forward and return portions of the typical HFC plant spectrum.

### 5.1.1.2 Single forward and return path channels per MAC layer domain

To keep management of carrier frequencies simple, each status monitoring system has a single forward channel and a single return channel. This does not preclude the use of multiple monitoring systems, each with its own individual forward and return RF channels.

A MAC layer domain consists of a single forward RF channel and a single return RF channel over which a single MAC layer bandwidth allocation and management protocol operates. It includes a centralized HE and multiple compliant transponders interfacing to managed OSP NEs. The centralized HE may support multiple HMS-based status monitoring systems, i.e. multiple MAC layer domains. Each OSP NE must only access a single forward channel and its associated single return channel, i.e. it must only operate within a single HMS MAC layer domain.

### 5.1.1.3 Network element (NE) term usage

The HMS MAC layer supports bandwidth management and reliable communications between a HE and multiple compliant transponders that interface to managed OSP NEs. Throughout this standard, the terms "compliant transponder", "transponder", and "NE" are used interchangeably when describing the MAC processes that support the exchange of data or other information between two or more entities at the DLL.

### 5.1.1.4 Packet

A packet is a unit of data exchanged between the HE and any of a number of managed OSP NEs at the DLL. Packets are strings of bytes that can be sent contiguously or be separated by periods of silence. Document *Outside Plant Status Monitoring – Physical (PHY) Layer Specification* describes specific byte transmission modes that must be implemented in both forward and return channels. A MAC packet consists of a MAC header, a variable-length payload, and a frame check sequence (see 5.3).

### 5.1.1.5 Most significant byte

Unless otherwise specified, it is assumed throughout this standard that the left-most entry in any numeric value is the most significant, i.e. for the address represented as 12-34-56-78-9A-BC the left-most entry '12' is the most significant value.

### 5.1.1.6 Byte number representation

Throughout this standard, bits labelled '0' are the least significant bits (LSBs) and bits labelled '7' are the most significant bits (MSBs). The bits in a given byte will be described with bit 7 (MSB) at the left and bit 0 (LSB) at the right. This convention has been adopted for presentation purposes only and has no effect on the actual bit transmission order. Bit transmission order details are provided in 5.2 of this standard.

### 5.1.1.7 Reserved bits

A number of bits are indicated with the word "Reserved" or the abbreviation "RSVD" in the various MAC packets described in this standard. Any receiving NE must ignore these bits when implementing this version of the MAC protocol.

## 5.2 MAC packet transport

### 5.2.1 Byte transmission format

Bytes transmitted over both forward and return channels are ten bits in length. They contain one start bit, eight bits of data, and one stop bit. The start bit has the binary value '0', and the stop bit has the binary value '1.'