



SLOVENSKI STANDARD
SIST EN 14765:2006
01-september-2006

Kolesa za otroke – Varnostne zahteve in preskusne metode

Bicycles for young children - Safety requirements and test methods

Kinderfahräder - Sicherheitstechnische Anforderungen und Prüfverfahren

Bicyclettes pour jeunes enfants - Exigences de sécurité et méthodes d'essai

iTeh STANDARD PREVIEW

Ta slovenski standard je istoveten z: EN 14765:2005

[SIST EN 14765:2006](https://standards.iteh.ai/catalog/standards/sist/b3f20afc-d5a4-416f-bb08-11cd122fa880/sist-en-14765-2006)

<https://standards.iteh.ai/catalog/standards/sist/b3f20afc-d5a4-416f-bb08-11cd122fa880/sist-en-14765-2006>

ICS:

43.150

97.190

SIST EN 14765:2006

en

iTeh STANDARD PREVIEW
(standards.iteh.ai)

SIST EN 14765:2006

<https://standards.iteh.ai/catalog/standards/sist/b3f20afc-d5a4-416f-bb08-11cd122fa880/sist-en-14765-2006>

ICS 43.150; 97.190

English Version

Bicycles for young children - Safety requirements and test methods

Bicyclettes pour jeunes enfants - Exigences de sécurité et méthodes d'essai

Kinderfahrräder - Sicherheitstechnische Anforderungen und Prüfverfahren

This European Standard was approved by CEN on 7 October 2005.

CEN members are bound to comply with the CEN/CENELEC Internal Regulations which stipulate the conditions for giving this European Standard the status of a national standard without any alteration. Up-to-date lists and bibliographical references concerning such national standards may be obtained on application to the Central Secretariat or to any CEN member.

This European Standard exists in three official versions (English, French, German). A version in any other language made by translation under the responsibility of a CEN member into its own language and notified to the Central Secretariat has the same status as the official versions.

CEN members are the national standards bodies of Austria, Belgium, Cyprus, Czech Republic, Denmark, Estonia, Finland, France, Germany, Greece, Hungary, Iceland, Ireland, Italy, Latvia, Lithuania, Luxembourg, Malta, Netherlands, Norway, Poland, Portugal, Slovakia, Slovenia, Spain, Sweden, Switzerland and United Kingdom.

[SIST EN 14765:2006](https://standards.iteh.ai/catalog/standards/sist/b3f20afc-d5a4-416f-bb08-11cd122fa880/sist-en-14765-2006)

<https://standards.iteh.ai/catalog/standards/sist/b3f20afc-d5a4-416f-bb08-11cd122fa880/sist-en-14765-2006>



EUROPEAN COMMITTEE FOR STANDARDIZATION
COMITÉ EUROPÉEN DE NORMALISATION
EUROPÄISCHES KOMITEE FÜR NORMUNG

Management Centre: rue de Stassart, 36 B-1050 Brussels

Contents

	page
Foreword	4
Introduction	5
1 Scope	6
2 Normative references	6
3 Terms and definitions	6
4 Requirements and test methods	7
4.1 Brake tests and strength tests – special requirements	7
4.1.1 Definition of brake tests	7
4.1.2 Definition of strength tests	7
4.1.3 Numbers and condition of specimens for the strength tests	7
4.1.4 Accuracy tolerances of test conditions for brake tests and strength tests	8
4.2 Toxicity	8
4.3 Sharp edges	8
4.4 Security and strength of safety-related fasteners	8
4.4.1 Security of screws	8
4.4.2 Minimum failure torque	8
4.4.3 Quick-release devices	8
4.4.4 Foot location devices	8
4.5 Crack detection methods	9
4.6 Protrusions	9
4.6.1 Requirement	9
4.6.2 Test method	10
4.7 Brakes	11
4.7.1 Braking-systems	11
4.7.2 Hand-operated brakes	11
4.7.3 Attachment of brake assembly and cable requirements	14
4.7.4 Brake-block and brake-pad assemblies — security test	14
4.7.5 Brake adjustment	14
4.7.6 Back-pedal brake	15
4.7.7 Braking-system — strength tests	15
4.7.8 Braking performance	18
4.8 Steering	19
4.8.1 Handlebar — dimensions and end fittings	19
4.8.2 Handlebar grips	19
4.8.3 Handlebar-stem — insertion depth mark or positive stop	20
4.8.4 Steering stability	20
4.8.5 Steering assembly — static strength and security tests	20
4.8.6 Handlebar and stem assembly – fatigue test	24
4.9 Frames	26
4.9.1 Frame and front fork assembly – impact test (falling mass)	26
4.9.2 Frame and front fork assembly – impact test (falling frame)	28
4.10 Front fork	29
4.10.1 General	29
4.10.2 Front fork – bending fatigue test	29
4.11 Wheels	29
4.11.1 Rotational accuracy	29
4.11.2 Wheel/tyre assembly – clearance	31
4.11.3 Wheel/tyre assembly – static strength test	31
4.11.4 Wheel retention	31
4.12 Rims, tyres and tubes	32

4.12.1	Tyre inflation pressure	32
4.12.2	Tyre and rim compatibility.....	32
4.13	Pedals and pedal/crank drive system.....	33
4.13.1	Pedal tread.....	33
4.13.2	Pedal clearance.....	33
4.13.3	Pedal-spindle impact test.....	34
4.13.4	Pedal/pedal-spindle —dynamic durability test	35
4.13.5	Drive system static strength test.....	36
4.13.6	Crank assembly — fatigue tests	37
4.14	Saddles and seat-pillars	38
4.14.1	Limiting dimensions	38
4.14.2	Seat-pillar – insertion-depth mark or positive stop.....	38
4.14.3	Saddle and seat pillar – security test	39
4.14.4	Saddle — static strength test.....	39
4.14.5	Seat-pillar — fatigue test	40
4.15	Chain-guard.....	41
4.16	Stabilizers	42
4.16.1	Mounting and dismounting	42
4.16.2	Dimensions.....	42
4.16.3	Vertical load test	42
4.16.4	Longitudinal load test.....	43
4.17	Luggage carriers.....	44
4.18	Lighting systems and reflectors	44
4.18.1	Lighting and reflectors	44
4.18.2	Wiring harness	44
4.18.3	Warning device	44
5	Instructions	44
6	Marking	45
6.1	Requirement	45
6.2	Durability test	46
6.2.1	Requirement	46
6.2.2	Test method.....	46
Annex A (informative)	Steering geometry	47
Bibliography.....		48

iTeh STANDARD PREVIEW
(standards.iteh.ai)

SIST EN 14765:2006

[https://standards.iteh.ai/catalog/standards/sist/b3f20afc-d5a4-416f-bb08-](https://standards.iteh.ai/catalog/standards/sist/b3f20afc-d5a4-416f-bb08-11cd122fa880/sist-en-14765-2006)

[11cd122fa880/sist-en-14765-2006](https://standards.iteh.ai/catalog/standards/sist/b3f20afc-d5a4-416f-bb08-11cd122fa880/sist-en-14765-2006)

Foreword

This European Standard (EN 14765:2005) has been prepared by Technical Committee CEN/TC 333 "Cycles", the secretariat of which is held by UNI.

This European Standard shall be given the status of a national standard, either by publication of an identical text or by endorsement, at the latest by May 2006, and conflicting national standards shall be withdrawn at the latest by November 2006

This European Standard is one of a series, dealing with cycles.

European Standards in this series are:

EN 14764	<i>City and trekking bicycles — Safety requirements and test methods</i>
TC 333 WI 00333002	<i>Cycles — Vocabulary – Terminology (ISO 8090: Modified)</i>
EN 14766	<i>Mountain-bicycles — Safety requirements and test methods</i>
EN 14781	<i>Racing bicycles — Safety requirements and test methods</i>
prEN 14872	<i>Bicycles — Accessories for bicycles — Luggage carriers</i>
prEN 15194	<i>Cycles — Electrically power assisted cycles — EPAC bicycle</i>

According to the CEN/CENELEC Internal Regulations, the national standards organizations of the following countries are bound to implement this European Standard: Austria, Belgium, Cyprus, Czech Republic, Denmark, Estonia, Finland, France, Germany, Greece, Hungary, Iceland, Ireland, Italy, Latvia, Lithuania, Luxembourg, Malta, Netherlands, Norway, Poland, Portugal, Slovakia, Slovenia, Spain, Sweden, Switzerland and United Kingdom.

Introduction

This European Standard has been developed in response to demand throughout Europe, and the aim has been to ensure that bicycles manufactured in compliance with it will be as safe as is practically possible. The tests have been designed to ensure the strength and durability of individual parts as well as of the bicycle as a whole, demanding high quality throughout and consideration of safety aspects from the design stage onwards.

If the bicycle is intended for the use on public roads, national traffic regulations apply.

The scope has been limited to safety considerations, and has specifically avoided standardisation of components.

No requirements on lighting equipment, reflectors and warning devices are specified in this European Standard, due to the existence of several different national regulations applicable in the European countries.

iTeh STANDARD PREVIEW (standards.iteh.ai)

SIST EN 14765:2006

<https://standards.iteh.ai/catalog/standards/sist/b3f20afc-d5a4-416f-bb08-11cd122fa880/sist-en-14765-2006>

1 Scope

This European Standard specifies safety and performance requirements and test methods for bicycles for young children, in respect of the design, assembly and testing of bicycles and sub-assemblies. Guidelines for instructions on the use and care of bicycles are also provided.

This European Standard applies to bicycles with a maximum saddle height of more than 435 mm and less than 635 mm (typical rider weight of 30 kg), and propelled by a transmitted drive to the rear wheel.

This European Standard does not apply to special bicycles intended for stunting (e.g. BMX bicycles).

NOTE For bicycles with a maximum saddle height of 435 mm see EN 71 and for bicycles with a saddle height of 635 mm or more see prEN 14764.

2 Normative references

The following referenced documents are indispensable for the application of this European Standard. For dated references, only the edition cited applies. For undated references, the latest edition of the referenced document (including any amendments) applies.

EN 71-3, *Safety of toys — Part 3: Migration of certain elements*

prEN 14872, *Bicycles — Accessories for bicycles — Luggage carriers*

ISO 1101, *Geometrical Product Specifications (GPS) — Geometrical tolerancing — Tolerances of form, orientation, location and run-out*

ISO 5775-1, *Bicycle tyres and rims — Part 1: Tyre designations and dimensions*

[SIST EN 14765:2006](#)

ISO 5775-2, *Bicycle tyres and rims — Part 2: Rims*

[log/standards/sist/b3f20afc-d5a4-416f-bb08-11cd122fa880/sist-en-14765-2006](#)

ISO 7636, *Bells for bicycles and mopeds — Technical specifications*

3 Terms and definitions

For the purposes of this European Standard, the following terms and definitions apply.

3.1

cycle

any vehicle that has at least two wheels and is propelled solely or mainly by the muscular energy of the person on that vehicle, in particular by means of pedals

3.2

bicycle

two-wheeled cycle

3.3

maximum saddle height

vertical distance from the ground to the top of the seat surface, measured with the seat in a horizontal position with the seat pillar set to the minimum insertion depth

[EN 71]

3.4

braking force

tangential rearward force between the tyre and the ground or the tyre and the drum or belt of the test machine

3.5**pedal tread surface**

surface of a pedal that is presented to the underside of the foot

3.6**toe-strap**

device to securely locate a rider's shoe on a pedal

3.7**toe-clip**

device attached to the pedal to grip the toe end of the rider's shoe but permitting withdrawal of the shoe

3.8**maximum inflation pressure**

maximum tyre pressure recommended by the tyre manufacturer for a safe and efficient performance

3.9**stabilizers**

removable auxiliary wheels fitted to enable the rider to balance

3.10**crank assembly**

for fatigue testing it consists of the two cranks, the pedal-spindles or adaptors, the bottom-bracket spindle, and the first component of the drive system, e.g. the chain-wheel cluster

3.11**exposed protrusion**

protrusion which through its location and rigidity could present a hazard to the rider either through heavy contact with it in normal use or should the rider fall onto it in an accident

3.12**quick-release devices**

device to fix or release a part without the use of a tool

3.13**visible crack**

crack which results from a test where that crack is visible to the naked eye

4 Requirements and test methods**4.1 Brake tests and strength tests – special requirements****4.1.1 Definition of brake tests**

Brake tests to which accuracy requirements apply, as in 4.1.4, are those specified in 4.7.2.2.3 to 4.7.8.4 inclusive.

4.1.2 Definition of strength tests

Strength tests to which accuracy requirements apply, as in 4.1.4, are those involving static, impact or fatigue loading as specified in 4.8 to 4.14 inclusive and 4.16.

4.1.3 Numbers and condition of specimens for the strength tests

In general, for static, impact and fatigue tests, each test shall be conducted on a new test sample, but if only one sample is available, it is permissible to conduct all of the tests on the same sample with the sequence of testing being fatigue, static and impact.

When more than one test is conducted on the same sample, the test sequence shall be clearly recorded in the test report or record of testing.

NOTE It should be noted that if more than one test is conducted on the same sample, earlier test can influence the results of subsequent tests. Also, if a sample fails when it has been subjected to more than one test, a direct comparison with single testing is not possible.

In all strength tests, specimens shall be in the fully finished condition.

4.1.4 Accuracy tolerances of test conditions for brake tests and strength tests

Unless stated otherwise, accuracy tolerances based on the nominal values shall be as follows:

Forces and torques	0/+5 %
Masses and weights	± 1 %
Dimensions	± 1 mm
Angles	± 1°
Time duration	± 5 s
Temperatures	± 2 °C
Pressures	± 5 %

4.2 Toxicity

The following items which come into intimate contact with the rider (i.e. causing any hazard due to sucking or licking) shall comply with the requirements of EN 71-3:

- all paints;
- handlebar handgrips;
- surface of the saddle.

ITeH STANDARD PREVIEW
(standards.iteh.ai)
<https://standards.iteh.ai/catalog/standards/sist/b3f20afc-d5a4-416f-bb08-11cd122fa880/sist-en-14765-2006>
SIST EN 14765:2006

4.3 Sharp edges

Exposed edges that could come into contact with the rider's hands, legs etc., during normal riding or normal handling and normal maintenance shall not be sharp.

4.4 Security and strength of safety-related fasteners

4.4.1 Security of screws

Any screws used in the assembly of suspension systems or screws used to attach e.g. generators, brake-mechanisms and mud-guards to the frame or fork or handlebar shall be provided with suitable locking devices, e.g., lock-washers, lock-nuts, or stiff nuts.

4.4.2 Minimum failure torque

The minimum failure torque of bolted joints for the fastening of handlebars, handlebar-stems, bar-ends, seats and seat-pillars shall be at least 50 % greater than the manufacturer's recommended tightening torque.

4.4.3 Quick-release devices

No quick-release devices of any type shall be used.

4.4.4 Foot location devices

Toe-straps and toe-clips shall not be fitted.

4.5 Crack detection methods

Standardised methods should be used to emphasise the presence of cracks where visible cracks are specified as criteria of failure in tests specified in this European Standard.

NOTE For example, suitable dye-penetrant methods are specified in ISO 3452.

4.6 Protrusions

4.6.1 Requirement

4.6.1.1 Exposed protrusions

Any rigid exposed protrusion longer than 8 mm (see L in Figure 1) after assembly except:

- the front gear-change mechanism at the chain wheel;
- the gear-change mechanism at the rear wheel;
- the rim-brake mechanism at the front and rear wheels;
- a lamp-bracket fitted on the head-tube;
- reflectors

shall terminate in a radius, R (see Figure 1), of not less than 6,3 mm. Such protrusions shall have a major end dimension, A , not less than 12,7 mm and a minor dimension, B , not less than 3,2 mm.

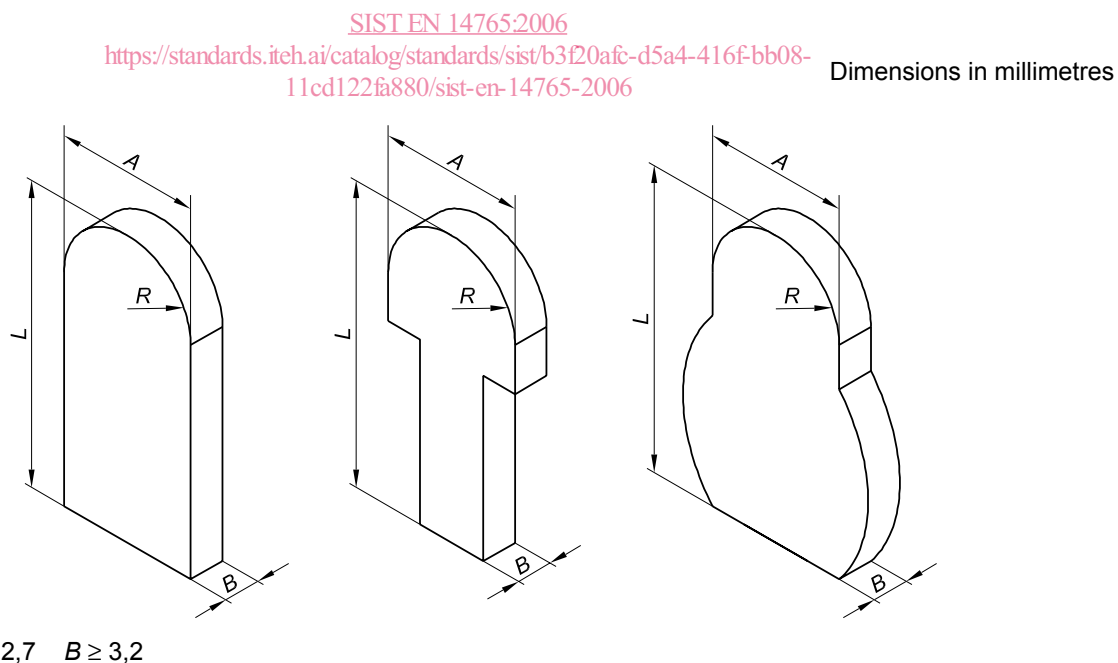

Figure 1 — Examples of minimum dimensions of exposed protrusions

4.6.1.2 Exclusion zone, protective devices and screw threads

There shall be no protrusions on the top tube of a bicycle frame between the saddle and a point 300 mm forward of the saddle, with the exception that control cables no greater than 6,4 mm in diameter and cable clamps made from material no thicker than 4,8 mm may be attached to the top tube.

Foam pads attached to the bicycle frame to act as protective cushions are permitted, provided that the bicycle meets the requirements for protrusions when the pads are removed.

A screw thread that is an exposed protrusion shall be limited to a protrusion length of one major diameter of the screw beyond the internally threaded mating part.

4.6.2 Test method

Conduct the test with a protrusion test cylinder (which simulates a limb) having the dimensions shown in Figure 2.

Dimensions in millimetres

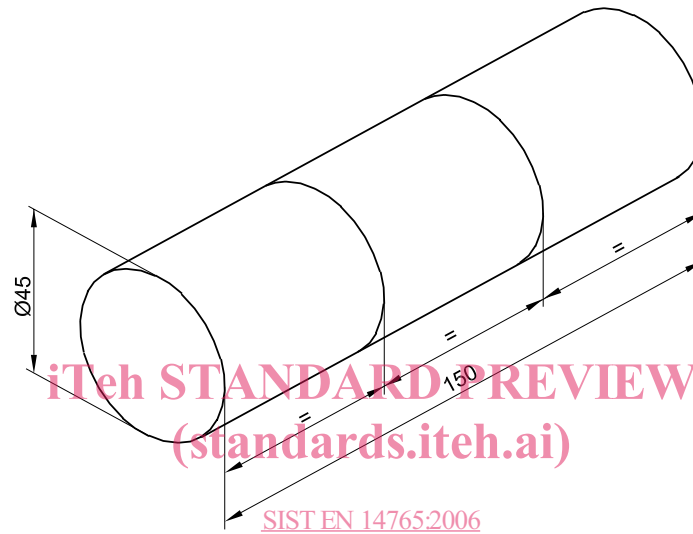

<https://standards.iteh.ai/catalog/standards/sist/b3f20afc-d5a4-416f-bb08-11cd122fa880/sist-en-14765-2006>

Figure 2 — Exposed protrusion test cylinder

Manoeuvre the test cylinder in all possible attitudes towards any rigid protrusion on the bicycle. If the central 50 mm long section of the cylinder contacts the protrusion, that protrusion shall be considered to be an exposed protrusion and it shall comply with 4.6.1.1.

Examples of protrusions that need and do not need to comply with the requirements are shown in Figure 3.

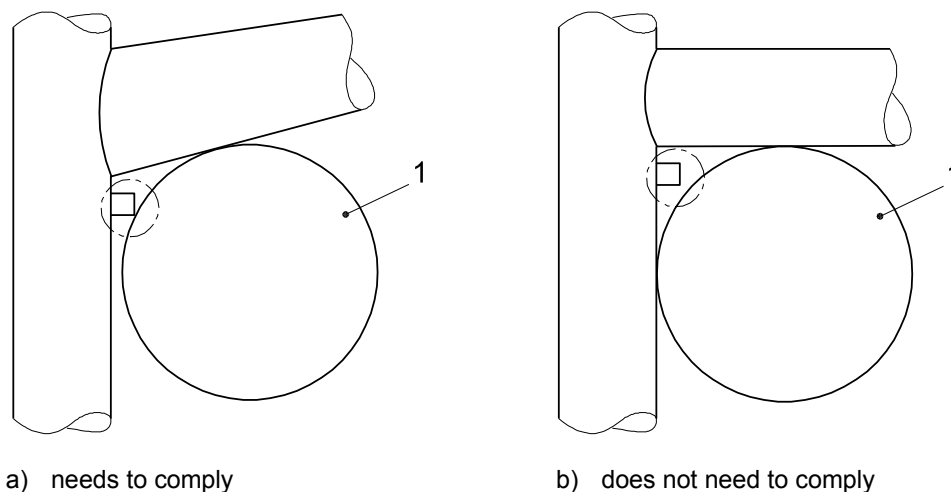
**Key**

1 Test cylinder

Figure 3 — Examples of protrusions

iTeh STANDARD PREVIEW
(standards.iteh.ai)

4.7 Brakes**4.7.1 Braking-systems**

Bicycles, whether or not fitted with a fixed transmitted drive, shall be equipped with at least two independent braking systems, one system operating on the front wheel and one on the rear.

NOTE It is recommended that the decision on whether the rear braking system is operated by the rider's hand or foot should be made in accordance with the legislation (or preference) of the country to which the bicycle is to be supplied.

Brake-blocks containing asbestos shall not be permitted.

4.7.2 Hand-operated brakes**4.7.2.1 Brake-lever position**

The hand-brake levers for front and rear brakes shall be positioned according to the legislation or custom and practice of the country in which the bicycle is to be sold, and the bicycle manufacturer shall state in the users instruction manual which lever operates the front brake and which operates the rear brake (see also Clause 5 k)).

4.7.2.2 Brake-lever grip dimensions**4.7.2.2.1 Requirement**

The maximum grip dimension, d , measured between the outer surfaces of the brake-lever and the handlebar, or the handlebar-grip or any other covering where present, shall not exceed 75 mm over a distance of 40 mm as shown in Figure 4. For dimension a see 4.7.2.2.2.

NOTE The range of adjustment on the brake-lever should permit these dimensions to be obtained.

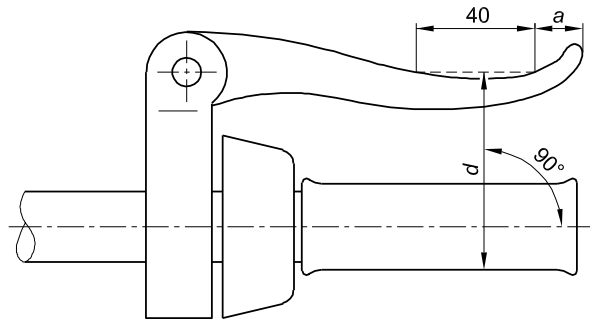
**Key**

- a* Distance between the last part of the lever intended for contact with the rider's fingers and the end of the lever
- d* Maximum grip dimension

Figure 4 — Handbrake-lever grip dimensions**4.7.2.2.2 Test method**

Fit the gauge illustrated in Figure 5 over the handlebar and handlebar-grip and the brake-lever as shown in Figure 6 so that the face A is in contact with the handlebar grip and the side of the brake-lever. Ensure that the face B is in uninterrupted contact with the part of the brake-lever which is intended for contact with the rider's fingers and that the gauge does not cause any movement of the brake-lever towards the handlebar or handlebar-grip. Measure the distance *a*, the distance between the last part of the lever intended for contact with the rider's fingers and the end of the lever (see 4.7.2.2.1 and 4.7.2.3).

<https://standards.iteh.ai/catalog/standards/sist/b3f20afc-d5a4-416f-bb08-11cd122fa880/sist-en-14765-2006>

Dimension in millimetres

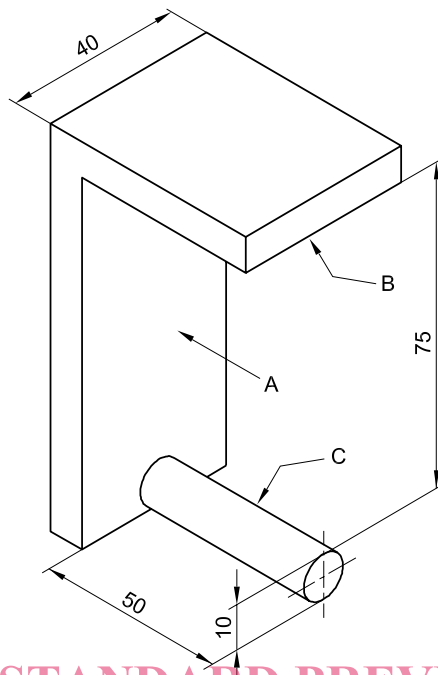

iTeh STANDARD PREVIEW (standards.iteh.ai)

Key

A = Face A

B = Face B

C = Rod

SIST EN 14765:2006

<https://standards.iteh.ai/catalog/standards/sist/b3f20afc-d5a4-416f-bb08-11cd122fa880/sist-en-14765-2006>

Figure 5 — Handbrake-lever grip dimension gauge

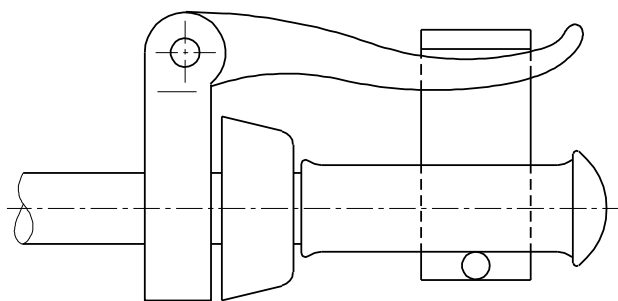

Figure 6 — Method of fitting the gauge to the handbrake-lever and handlebar (minimum grip length is shown)

4.7.2.3 Handbrake levers — position of applied force

For the purposes of all braking tests in this European Standard the test force shall be applied at a distance, b , which is equal to either dimension a as determined in 4.7.2.2.2 or 25 mm from the free end of the brake-lever, whichever is the greater (see Figure 7).