



# Continuous mechanical handling equipment — Safety code for belt conveyors — Examples for protection of pinch points on idlers

*Engins de manutention continue — Code de sécurité des transporteurs à courroie — Exemples de protection des points de coïncement sur les rouleaux*

## Foreword

ISO (the International Organization for Standardization) is a worldwide federation of national standards bodies (ISO member bodies). The work of preparing International Standards is normally carried out through ISO technical committees. Each member body interested in a subject for which a technical committee has been established has the right to be represented on that committee. International organizations, governmental and non-governmental, in liaison with ISO, also take part in the work.

The main task of ISO technical committees is to prepare International Standards. In exceptional circumstances a technical committee may propose the publication of a technical report of one of the following types :

- type 1, when the necessary support within the technical committee cannot be obtained for the publication of an International Standard, despite repeated efforts;
- type 2, when the subject is still under technical development requiring wider exposure;
- type 3, when a technical committee has collected data of a different kind from that which is normally published as an International Standard ("state of the art", for example).

Technical reports are accepted for publication directly by ISO Council. Technical reports types 1 and 2 are subject to review within three years of publication, to decide if they can be transformed into International Standards. Technical reports type 3 do not necessarily have to be reviewed until the data they provide is considered no longer valid or useful.

ISO/TR 8435 was prepared by Technical Committee ISO/TC 101, *Continuous mechanical handling equipment*.

The reasons which led to the decision to publish this document in the form of a technical report type 3 are explained in the Introduction.

UDC 621.867.2 : 614.8

Ref. No. : ISO/TR 8435-1984 (E)

**Descriptors** : handling equipment, continuous handling, belt conveyors, idlers, safety requirements.

© International Organization for Standardization, 1984 ●

Printed in Switzerland

Price based on 13 pages

## 0 Introduction

This Technical Report supplements the various safety standards for conveyors for loose bulk materials and unit loads. It gives examples of the many kinds of hazards connected with belt conveyors at pinch points on idlers. This Technical Report incorporates illustrative examples which show in principle how sufficient safety can be achieved, without excluding other methods which give the same level of safety. As this is a subject that cannot be considered as suitable for publication as an International Standard, it was decided to publish the document as a technical report.

## 1 Scope and field of application

This Technical Report gives examples of the kinds of hazards connected with running belts between idlers and fixed parts of belt conveyors and also between the idlers themselves.

It describes different safety devices which will achieve acceptable safety levels for the operation of this type of continuous mechanical handling equipment (in accordance with the nomenclature given in ISO 2148).

This Technical Report supplements International Standards ISO 1819 and ISO 7149 and Technical Report ISO/TR 5045, all of which deal with safety issues.

## 2 References

ISO 1819, *Continuous mechanical handling equipment — Safety code — General rules.*

ISO 2148, *Continuous handling equipment — Nomenclature.*

ISO/TR 5045, *Continuous mechanical handling equipment — Safety code for belt conveyors — Examples for guarding of nip points.*

ISO 7149, *Continuous handling equipment — Safety code — Special rules.*

<https://standards.iteh.ai/catalog/standards/sist/b56410cc-866a-4e78-9bb0-e5137a9e2493/iso-tr-8435-1984>

## 3 Danger points

The risk of crushing occurs at any points where, in the event of the hands getting caught, the belt does not have a clearance  $f$  (see figure 1 and succeeding figures) of at least 50 mm or does not yield to produce a clearance of the same size.

NOTE — This lower limit of 50 mm for the clearance  $f$  ensures that a hand caught in the gap will only be pulled in by a weak force, so that it can always be pulled out. However, clearance  $f$  should never have a value between 70 mm and 120 mm, because then larger parts of the body (for example a fist or an arm) may be pulled in. Between 50 mm and 70 mm the geometrical relations prevent these limbs from being caught; clearances of more than 120 mm mean that they can be pulled out without trouble.

All these dimensions are only valid for belt conveyors with speeds up to approximately 3 m/s, because additional dynamic effects occur at higher speeds.

Danger points of this kind exist, for instance, in the following places.

### 3.1 Feed hoppers

At points where the flexible packing strips of feed hoppers placed on top of the belt do not allow the required clearance  $f$  of the belt above the idler, when the hopper is loaded (see figure 1).

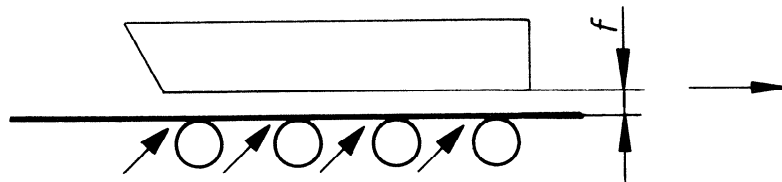

Figure 1

### 3.2 Skirt plates

At points where the skirt plates or the flexible packing strips do not allow the required clearance  $f$  of the belt above the idler (see figure 2).

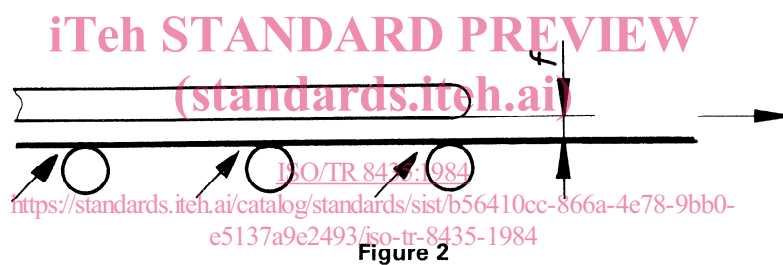

Figure 2

### 3.3 Bracing above idlers

At points where, in the return belt zone, the required clearance  $f$  is not maintained between the belt above the idlers and the longitudinal or cross-bracing of the structure above them (see figure 3).

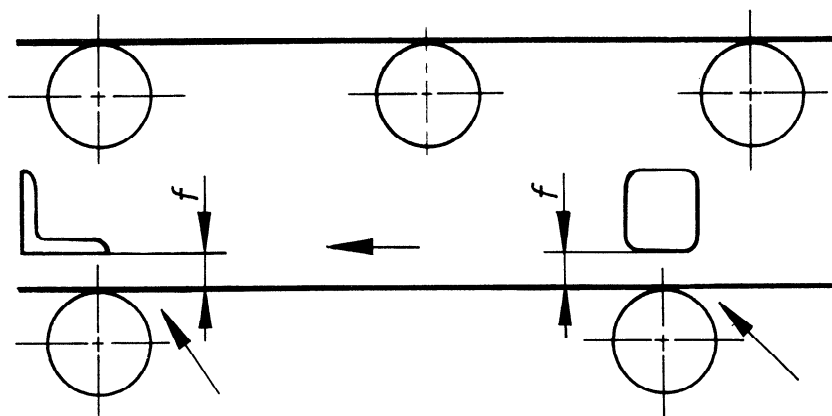

Figure 3

### 3.4 Between idlers

At points where clearance  $f$  is not maintained between the belt above the return idlers and the carrying idlers arranged above them (see figure 4).

Since, in this case, a trapping point also occurs between the two moving surfaces inside the conveyor structure, the clearances laid down above shall be respected, if the trapping point can be reached.

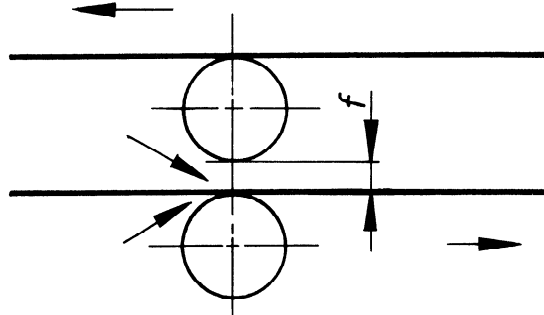

Figure 4

iTeh STANDARD PREVIEW  
(standards.iteh.ai)

ISO/TR 8435:1984

### 3.5 Between idlers and a fixed surface

<https://standards.iteh.ai/catalog/standards/sist/b56410cc-866a-4e78-9bb0-e5137a9e2493/iso-tr-8435-1984>

At points where clearance  $f$  between the belt above the idler and the bottom of a fixed surface is not maintained in the idler zone (see figure 5).

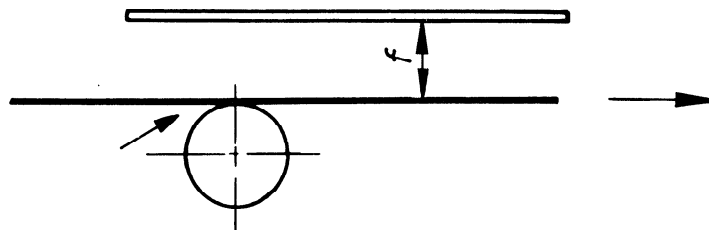

Figure 5

## 4 Safeguards

This clause gives examples of methods for achieving the required clearance  $f$  in certain circumstances. It should always be checked in the first instance whether the design allows clearance  $f$  to be maintained.

Should clearance  $f$  not be maintained, examples of satisfactory safeguards are illustrated.

## 4.1 Feed hoppers

### 4.1.1 Protection using a sloping arrangement of the skirt plates and flexible sealing strip

For hand-fed conveyors or conveyors designed to carry light material, a sloping arrangement of the skirt plates combined with a sufficiently wide flexible sealing strip is suitable. The flexible sealing strip shall lie relatively flat against the belt and, by design and when under the load of the material conveyed, it shall yield to produce clearance  $f$  (see figure 6).

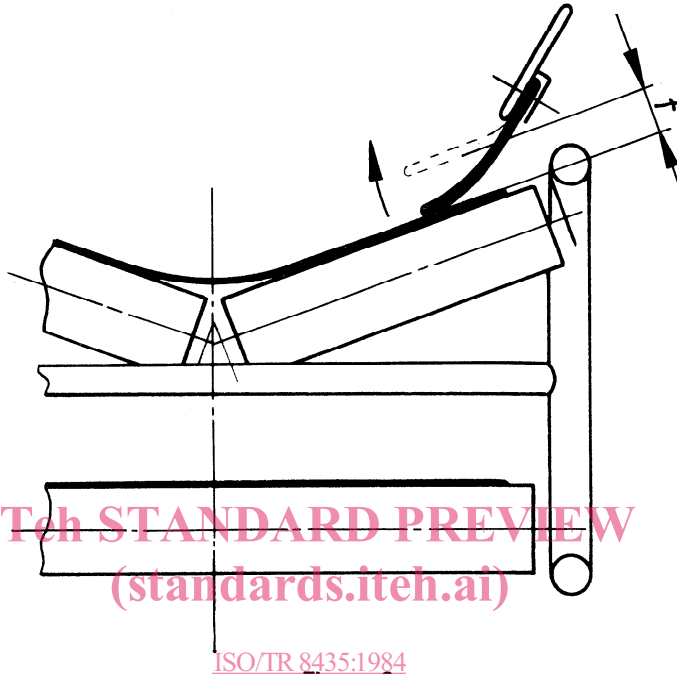

ISO/TR 8435:1984

Figure 6

<https://standards.iteh.ai/catalog/standards/sist/656410cc-866a-4e78-9bb0-e5137a9e2493/iso-tr-8435-1984>

### 4.1.2 Side-guards to guard carrying idlers in the hopper zone when the clearance $f$ is not maintained

4.1.2.1 Full side-guards extending down to the bottom of the supporting structure are possible on light mobile conveyors (see figure 7), especially if fed by hand.

If these conveyors are moved regularly, this will avoid build-up of material.

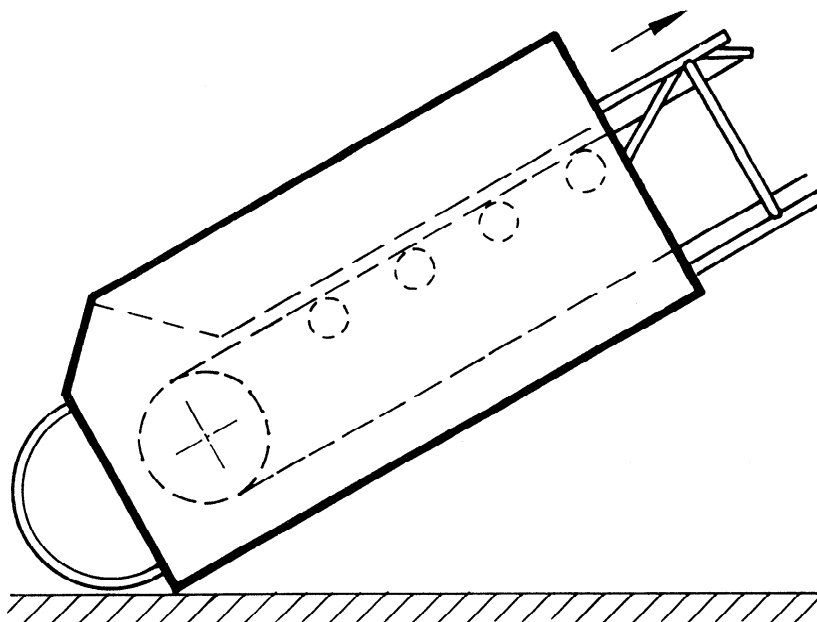
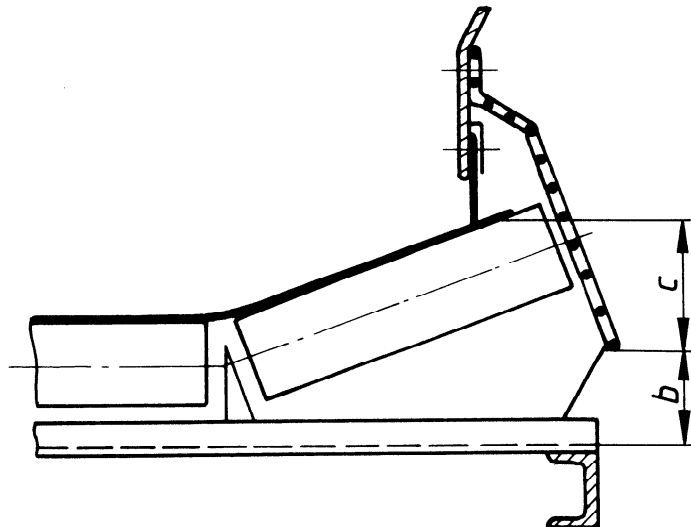

Figure 7

4.1.2.2 On fixed conveyors the size of which permits a distance ( $b + c$ ) equal to or greater than 250 mm (see figure 8), side-guards may be used which extend downwards from the danger zone by at least  $c = 150$  mm.

The guards shall allow a gap  $b$  of between 75 and 100 mm (in accordance with national legislation) for cleaning the deck plate and idler supports without having to remove the cover guard. Wire-mesh will ensure that the guarded parts are kept in view at all times.



**iTeh STANDARD PREVIEW**  
**Figure 8**  
**(standards.iteh.ai)**

If the conveyor structure and hopper can shift in relation to each other, this fact shall be taken into account when deciding on the dimensions for the guard.

[ISO/TR 8435:1984](https://standards.iteh.ai/catalog/standards/sist/b56410cc-866a-4e78-9bb0-e5137a9e2493/iso-tr-8435-1984)

<https://standards.iteh.ai/catalog/standards/sist/b56410cc-866a-4e78-9bb0-e5137a9e2493/iso-tr-8435-1984>

**4.1.3 Guarding the ends**

Guards to prevent access to the danger points at the idlers, at the inflow and outflow ends of the hopper, may be fitted.

Any idler which is located outside, but within a distance not greater than or equal to 300 mm from, either end of the hopper is considered to be hazardous (see figure 9).

4.1.3.1 At the outflow end of the hopper, the guard shall extend at least 300 mm beyond the end of the hopper and at least 150 mm beyond the last idler considered to be hazardous (see figure 9).

If there is no idler within this zone of 300 mm, the guard shall extend at least 300 mm beyond the last idler under the hopper (see figure 10).

Dimensions in millimetres

Dimension in millimetres

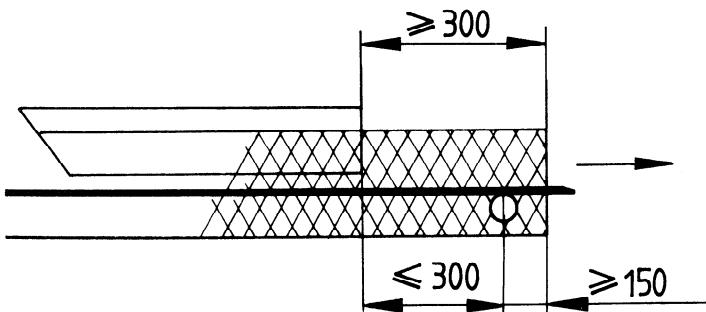

**Figure 9**

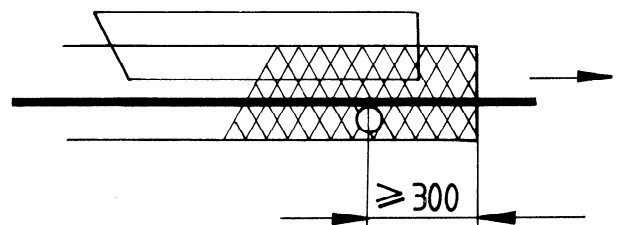

**Figure 10**

4.1.3.2 At the inflow end of the hopper, safety shall be ensured by:

- a) a side-guard extending to at least 850 mm from the first idler considered to be hazardous in the area of the hopper (see figures 11 and 14) or by a side-guard extending up to the first obstacle (idler or pulley) upstream of the idler considered to be hazardous and at least 300 mm beyond (see figures 12 and 13);

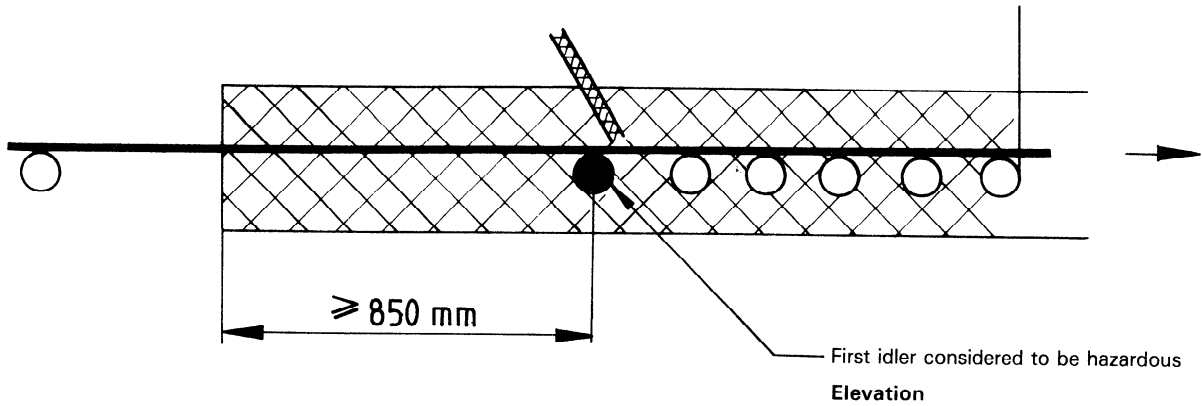

Figure 11

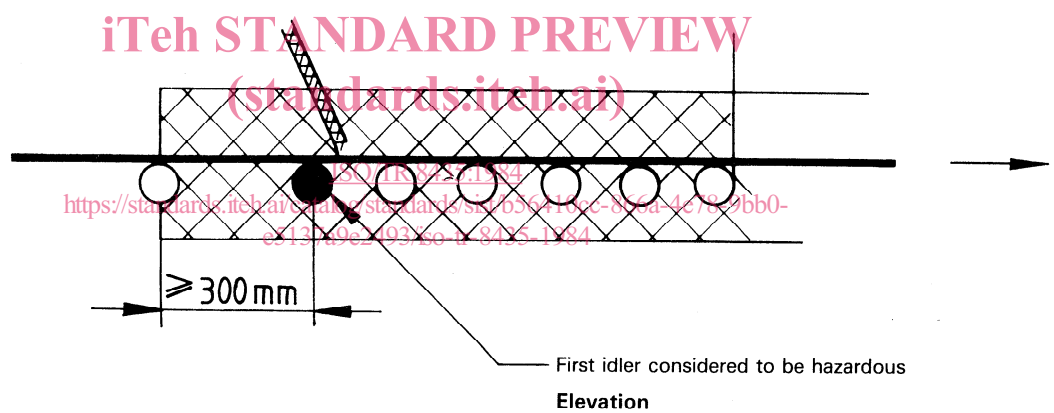

Figure 12

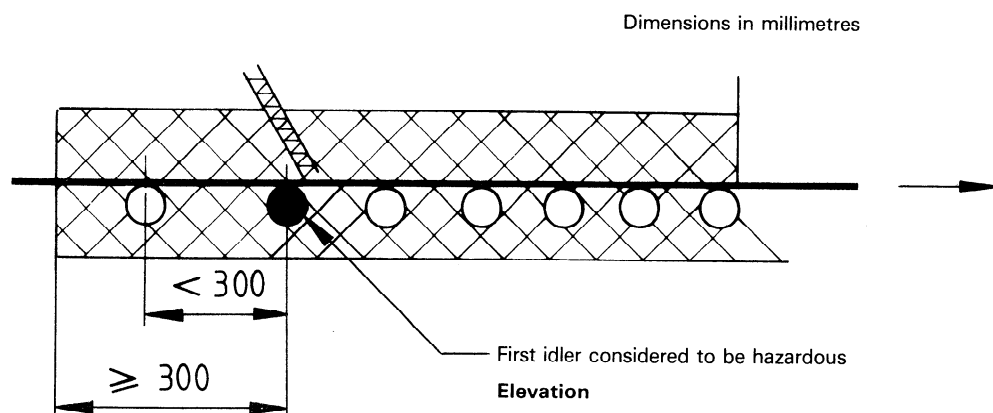
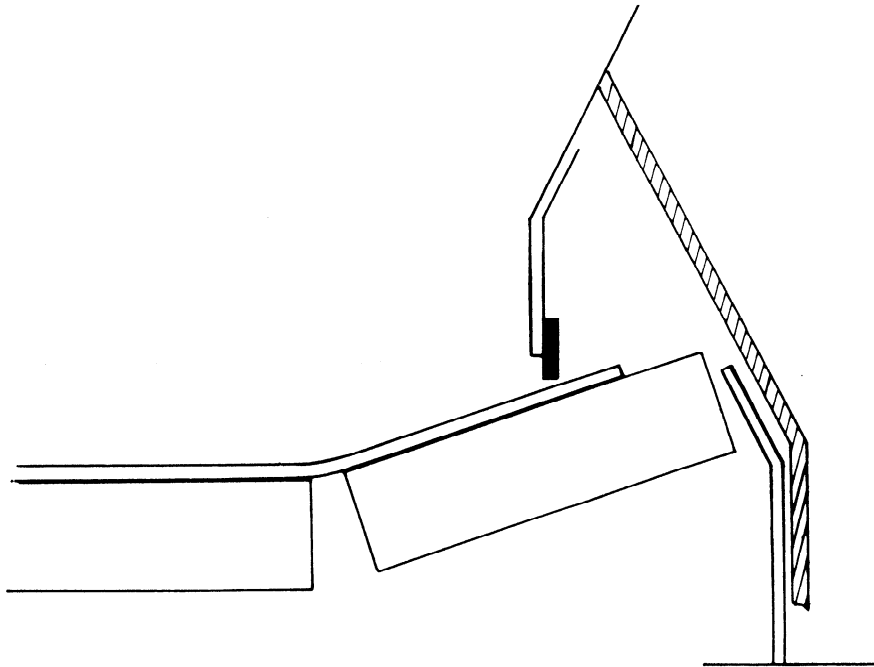

Figure 13



Cross-section

Figure 14

b) a cross-guard placed directly in front of the first idler considered to be hazardous either integral with the side-guard or mounted independently, extending along the full length of the idler, in accordance with the dimensions given in figures 15, 16 and 17.

STANDARD PREVIEW  
(standards.iteh.ai)

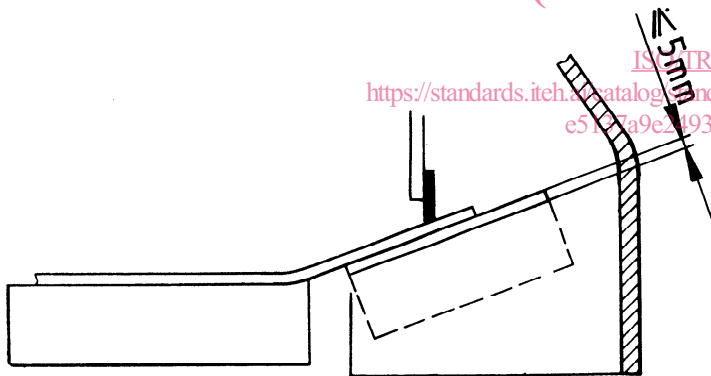

Cross-section

Figure 15

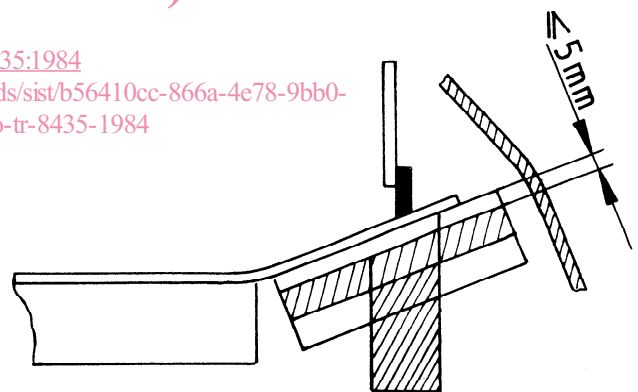

Cross-section

Figure 16

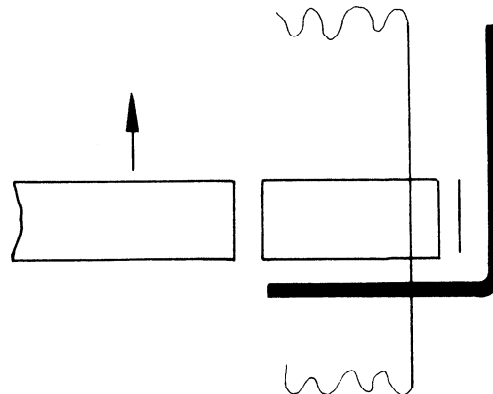

Plan view

Figure 17



## 4.2 Skirt plates

### 4.2.1 Protection using a sloping arrangement of the skirt plates and flexible sealing strip

For conveyors designed to carry light material, a sloping arrangement of the skirt plates combined with a sufficiently wide flexible sealing strip is suitable. The flexible sealing strip shall lie relatively flat against the belt and, by design and when under the load of the material conveyed, it shall yield to produce clearance  $f$  (see figure 18).

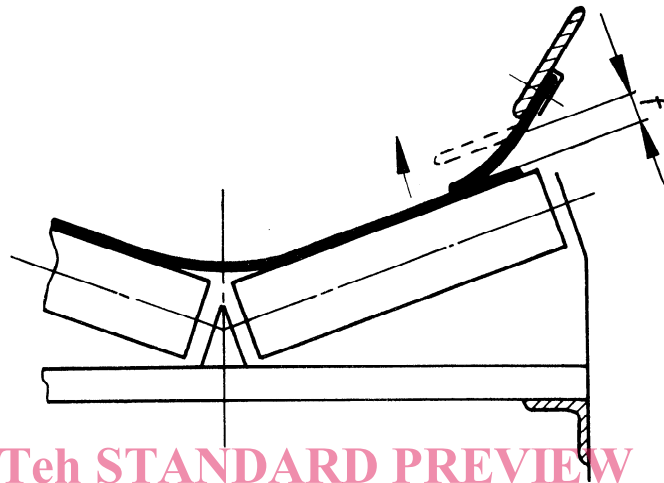

iTeh STANDARD PREVIEW  
(standards.iteh.ai)  
Figure 18

ISO/TR 8435:1984

### 4.2.2 Side-guards

<https://standards.iteh.ai/catalog/standards/sist/b56410cc-866a-4e78-9bb0-e5137a9e2493/iso-tr-8435-1984>

On fixed conveyors the size of which permits a distance  $(b + c)$  equal to or above 250 mm (see figure 19), side-guards may be used which extend downwards from the danger zone by at least  $c = 150$  mm.

The guards shall allow a gap  $b$  of between 75 and 100 mm (in accordance with national legislation) for cleaning the deck plate and idler supports without having to remove the cover guard. Wire-mesh will ensure that the guarded parts are kept in view at all times.

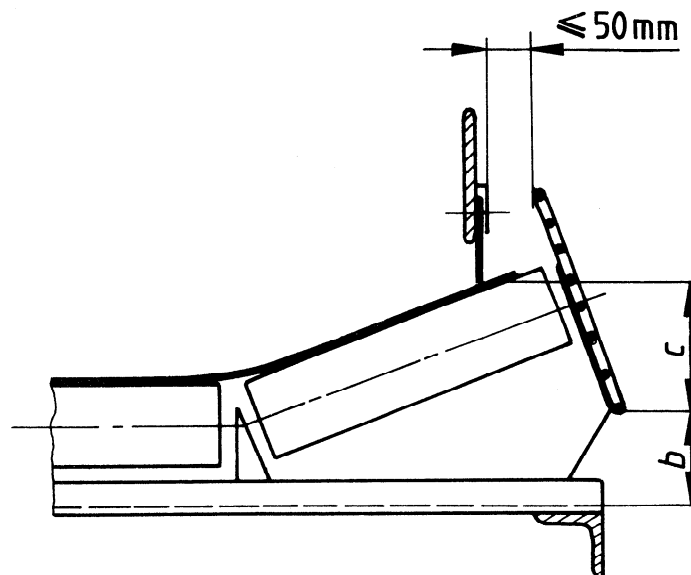

Figure 19