



Standard Specification for Anodes, Sacrificial Zinc Alloy¹

This standard is issued under the fixed designation F 1182; the number immediately following the designation indicates the year of original adoption or, in the case of revision, the year of last revision. A number in parentheses indicates the year of last reapproval. A superscript epsilon (ϵ) indicates an editorial change since the last revision or reapproval.

1. Scope

1.1 This specification covers the requirements for zinc anodes in the form of slabs, plates, discs, and rods for corrosion protection (cathodic protection) of metals and alloys.

1.2 The anodes are primarily intended to reduce corrosion of surface ship and submarine hulls, steel and aluminum equipment and structures, sea chests, sonar domes, and the seawater side of condensers and other heat exchangers.

1.3 The values stated in inch-pound units are to be regarded as standard. The metric (SI) units, given in parentheses, are for information purposes only and may be approximate.

1.4 *This standard does not purport to address the safety concerns associated with its use. It is the responsibility of the user of this standard to establish appropriate safety and health practices and determine the applicability of regulatory limitations prior to use.*

2. Referenced Documents

2.1 *Order of Precedence*—In the event of a conflict between the text of this specification and the references cited herein, the text of this specification shall take precedence.

2.2 ASTM Standards

A 36/A36M Specification for Structural Steel²

B 21 Specification for Naval Brass Rod, Bar, and Shapes³

B 103 Specification for Phosphor Bronze Plate, Sheet, Strip, and Rolled Bar³

D 3951 Practice for Commercial Packaging⁴

E 290 Test Method for Semi-Guided Bend Test for Ductility of Metallic Materials⁵

E 536 Test Method for Chemical Analysis of Zinc and Zinc Alloys⁶

2.3 Military Standards:⁷

MIL-STD-105 Sampling Procedures and Tables for Inspection by Attributes

MIL-STD-129 Marking for Shipment and Storage

MIL-STD-1186 Cushioning, Anchoring, Bracing, Blocking, and Waterproofing; With Appropriate Test Methods

2.4 Military Specification:

MIL-P-15011 Pallets Material Handling, Wood Post Construction, 4-Way Entry⁷

2.5 Federal Specifications:⁷

PPP-B-601 Boxes, Wood, Cleated Plywood

PPP-B-621 Boxes, Wood, Nailed and Lock-Corner

PPP-B-636 Boxes, Shipping, Fiberboard

2.6 American National Standards Institute Standard:

ANSI/ASME B1.20.1—Pipe Threads, General Purpose (Inch)⁸

3. Classification

3.1 The anodes shall be of the following classes and types, as specified (see 4.1.2):

3.1.1 Class 1—Cast-in cores:

3.1.1.1 *Type ZHS*—Zinc, hull slab, steel straps, 23 and 42-lb (10 and 19-kg) sizes.

3.1.1.2 *Type ZHB*—Zinc, hull slab, brass straps, 23-lb (10-kg) size.

3.1.1.3 *Type ZHC*—Zinc, hull slab, core strap, 23 and 42-lb (10 and 19-kg) sizes.

3.1.1.4 *Type ZSS*—Zinc, submarine slab, steel strap, 12 and 24-lb (5 and 11-kg) sizes.

3.1.1.5 *Type ZTS*—Zinc, teardrop shape, steel strap, 5-lb (2-kg) size.

3.1.1.6 *Type ZEP*—Zinc, heat exchanger or fair water disc, (pipe core or pipe bushing core):

Style A square slab, 9-lb (4-kg) size

Style B circular slab, various sizes

Style C semicircular slab, 23-lb (10-kg) size

3.1.1.7 *Type ZBP*—Zinc, bar, pipe core, 8-lb (4-kg) size.

3.1.1.8 *Type ZDM*—Zinc, segmented disc, machine formed interlocking core, various sizes.

3.1.2 Class 2—Plain, no cores;

3.1.2.1 *Type ZRN*—Zinc, rod, no core, extruded, drawn or rolled.

3.1.2.2 *Type ZPN*—Zinc, plate, no core, rolled.

3.2 The letter designations of types of anodes have the following meanings:

¹ This specification is under the jurisdiction of ASTM Committee F-25 on Ships and Marine Technology and is the direct responsibility of Subcommittee F25.07 on General Requirements.

Current edition approved June 29, 1990. Published August 1990. Originally published as F 1182 - 88. Last previous edition F 1182 - 88.

² *Annual Book of ASTM Standards*, Vol 01.04.

³ *Annual Book of ASTM Standards*, Vol 02.01.

⁴ *Annual Book of ASTM Standards*, Vol 15.09.

⁵ *Annual Book of ASTM Standards*, Vol 03.01.

⁶ *Annual Book of ASTM Standards*, Vol 03.06.

⁷ Available from Standardization Documents, Order Desk, Building 4, Section D, 700 Robbins Ave., Philadelphia, PA 19111-5094, Attn: NPODS.

⁸ Available from American National Standards Institute, 11 W. 42nd St., 13th Floor, New York, NY 10036.

3.2.1 The first letter designates anode metal:

Z zinc

3.2.2 The second letter designates the shape or general use:

H hull slab
 S submarine slab
 T teardrop shape
 E heat exchanger slab
 R rod, cylindrical
 P plate
 B bar, square
 D disc, segmented

3.2.3 The third letter designates the core:

B brass straps
 S steel straps
 C core strap
 P pipe core
 M machine formed interlocking core
 N no core

4. Ordering Information

4.1 Orders for material under this specification shall include the following information:

4.1.1 ASTM designation and year of issue,

4.1.2 Class and type (see 3.1),

4.1.3 Style of Type ZEP, if required (see 3.1.1.6 and Fig. 1),

4.1.4 Diameter of Type ZEP, Style B, if required (see Fig. 1),

4.1.5 For Type ZDM, whether straight or tapered thread support plug head is required (see section 5.1.4.2.)

4.1.6 Diameter of Type ZDM, if required (see Fig. 2),

4.1.7 Length, width, and thickness of Type ZHS, if required (see Fig. 3 and Fig. 4),

4.1.8 Whether Type ZHC is for surface ship or submarine usage, if required (see Figs. 5-8),

4.1.9 Pipe or bolt diameter of Type ZRN, if required (see Fig. 9),

4.1.10 Thickness of Type ZPN, if required (see 9.2.1),

4.1.11 Quantity required (see 4.2),

4.1.12 Quality assurance certification, if required (see 15.1), and

4.1.13 Optional requirements, if any (see S1 through S3).

4.2 The order for anodes should specify the exact number of anodes required (see 4.1.11). Acquisition of anodes by weight

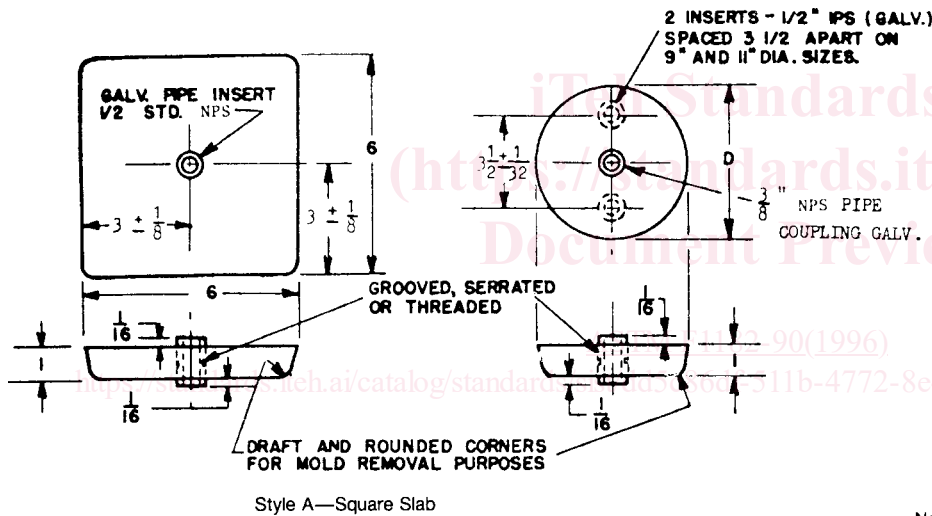

Style A—Square Slab

NOTE—Tolerance for center $\pm 1/16$ in.

Diameter, D, in., $\pm 1/16$ in.	Approximate Weight, lb	Surface Area, in. ²
11	24	130
9	16	92
6	7.1	47
5	4.9	36
4	3.19	26
3	1.78	16
2	0.79	9

Style B—Circular Slab

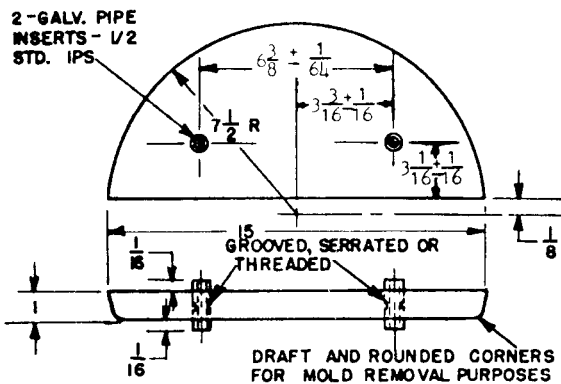

Style C—Semicircular Slab

NOTE 1—1 in. = 25.4 mm.

NOTE 2—1 lb. = 0.45 kg.

NOTE 3—Approximate weight for Style A is 9 lb; approximate weight for Style C is 23 lb.

NOTE 4—All dimensions are in inches.

FIG. 1 ZEP Heat Exchanger Slab

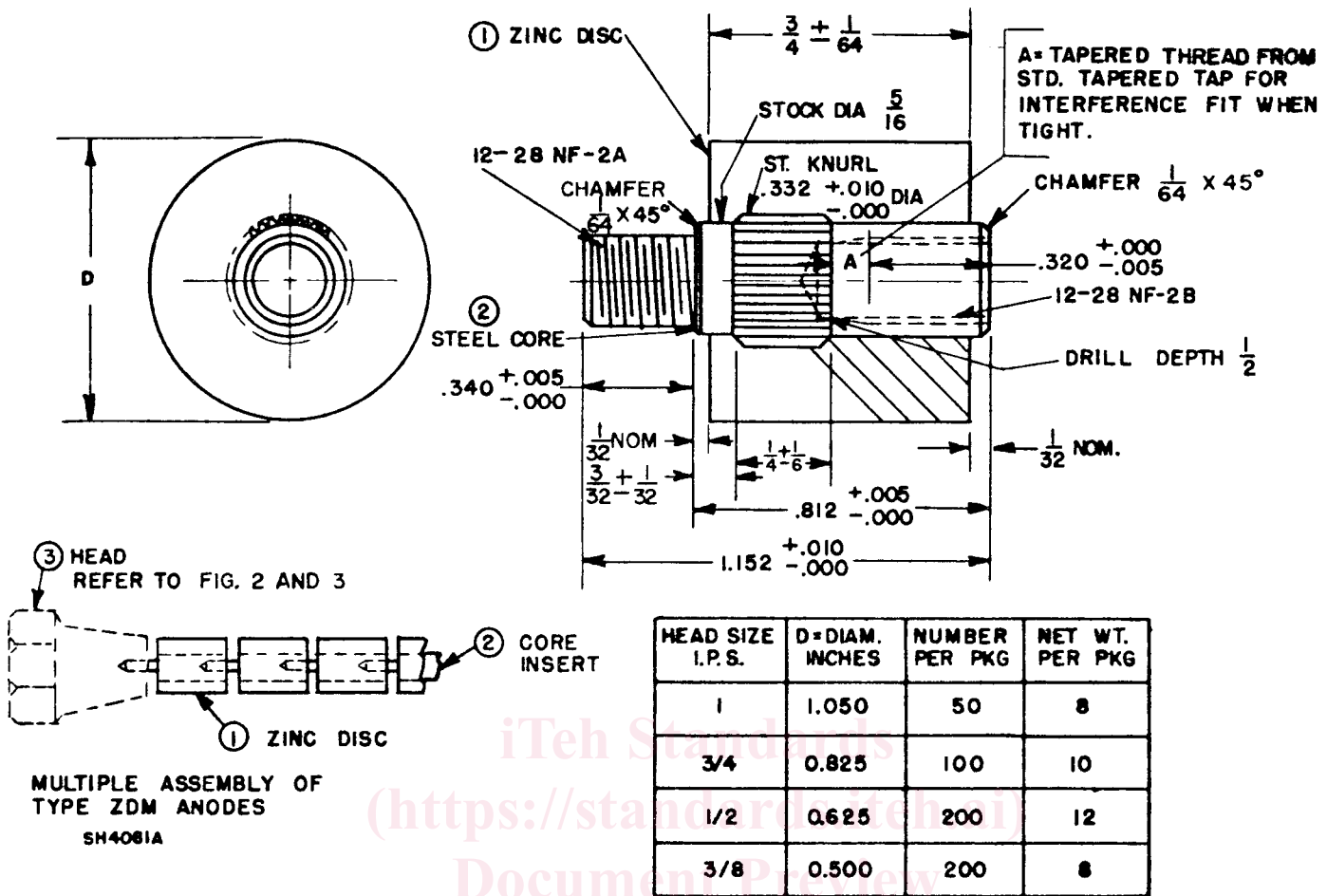

NOTE 1—All dimensions are in inches.
NOTE 2—1 in. = 25.4 mm.

FIG. 2 Zinc, Segmented Disc, Machine-Formed Interlocking Core, Type ZDM

is not practical and is not recommended.

4.3 When material is ordered in the form of slabs, bars, discs, or rods, these terms refer merely to the general form and dimensions of the material and do not have any technical significance as to the methods of manufacture.

5. Materials and Manufacture

5.1 Materials:

5.1.1 Types ZHS, ZHC, ZSS, and ZTS anodes shall have steel strap cores in accordance with Specification A 36/A36M. The steel shall be coated with zinc, either by the hot-dip or electrodeposition method, to a minimum of 0.0005 in. (0.013 mm).

5.1.2 Type ZHB anodes shall have brass strap cores in accordance with alloy 482 of Specification B 21 or phosphor bronze straps in accordance with C51000 of Specification B 103. The brass or bronze straps shall be coated with zinc to a minimum thickness of 0.0005 in. (0.013 mm). Lack of adhesion of the zinc coating at bend or absence of zinc coating at cut edges will not be cause for rejection of fabricated anodes. Cracks in the base metal shall be cause for rejection.

5.1.2.1 The maximum copper content in the zinc, as specified in Table 1, may be increased to 0.020 % for Type ZHB anodes.

5.1.3 Types ZEP and ZBP anodes shall have core inserts made from zinc coated steel pipe or pipe couplings. The minimum thickness of the coating shall be as specified in 5.1.1.

5.1.4 Type ZDM anodes shall have machine formed interlocking cores in accordance with commercial grade mild or leaded steel. The cores shall be flash coated with zinc, tin, or aluminum before assembly within the anodes.

5.1.4.1 This core insert consists of an integral piece having a threaded male stud at one end and a tapped hole at the other end. Provision has been made to achieve self-locking characteristics to interlocking threaded assemblies of multiple segmented anode discs by interference fit of bottom male threads into a taper tapped hole.

5.2 Manufacture:

5.2.1 All anodes covered under this specification shall be manufactured by any process suitable to the contracting agency provided they meet the mechanical properties and other requirements of this specification.

5.2.2 For Types ZHS, ZHB, ZHC, ZSS, and ZTS anodes, open or closed molds may be used. Cores and straps shall be positioned so that they are embedded $\frac{1}{4}$, $\frac{1}{8}$, or $-\frac{1}{16}$ in. (6, +3, or -2 mm) as shown on Figs. 3-5, Fig. 7, and Fig. 10 and Fig. 11, which may be measured from either surface of the

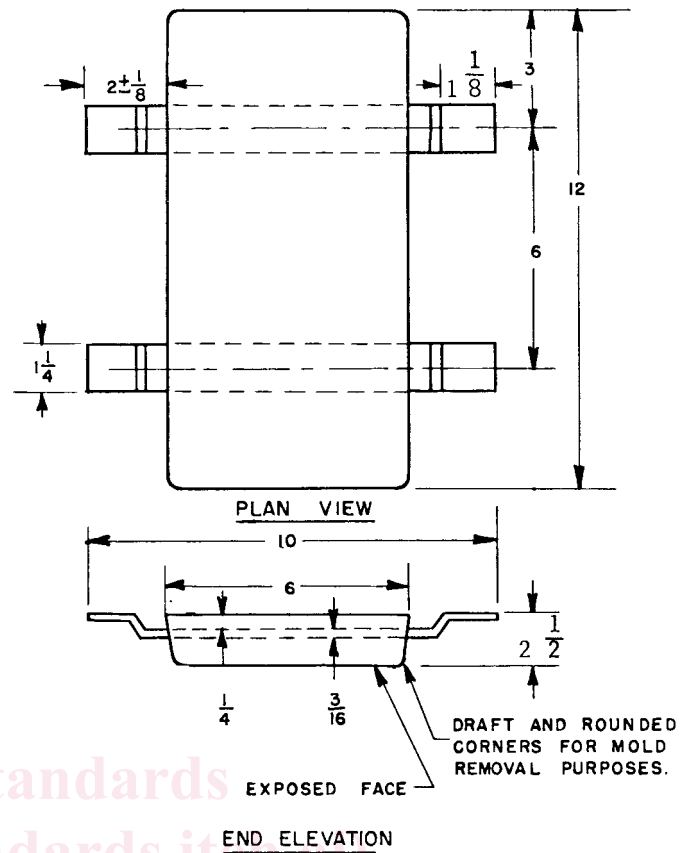
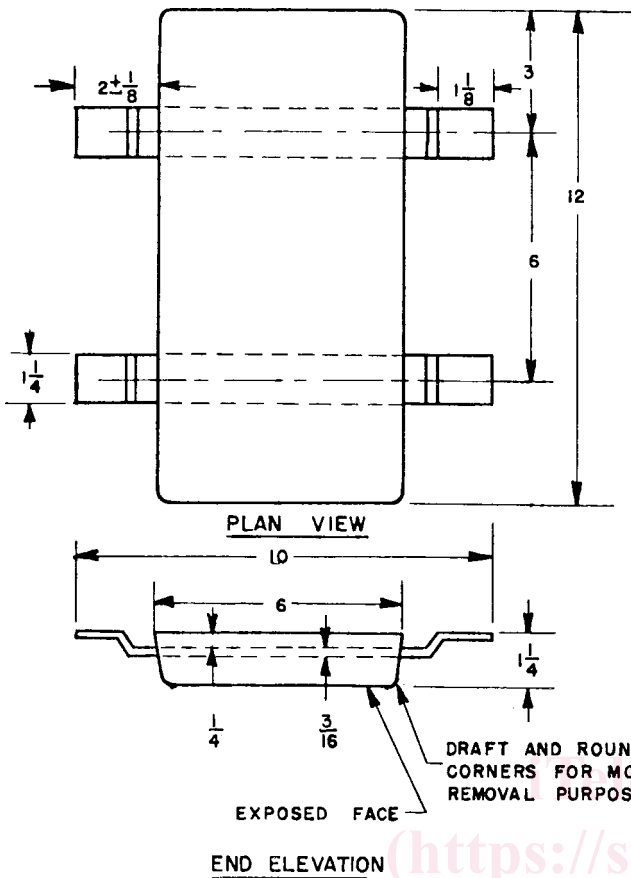

NOTE 1—Anode may be cast with strap in the up or down position. All dimensions (inches) refer to the wider and longer edges of the anodes.
 NOTE 2—Tolerance $\pm 1/8$ in.
 NOTE 3—1 in. = 25.4 mm.
 NOTE 4—Minimum weight 21.5 lb (9.7 kg).

FIG. 3 Zinc Hull Slab (Steel Straps), Type ZHS-23; Zinc Hull Slab (Brass Straps), Type ZHB

NOTE 1—Anode may be cast with strap in the up or down position. All dimensions (inches) refer to the wider and longer edges of the anode.
 NOTE 2—Tolerance $\pm 1/8$ in.
 NOTE 3—1 in. = 25.4 mm.
 NOTE 4—Minimum weight 41 lb (18.6 kg).

FIG. 4 Zinc Hull Slab (Steel Straps), Type ZHS-42

anode as applicable, except Fig. 11 (bottom), which shall be embedded $3/8$, $+1/8$, or $-1/16$ in. (10, +3, or -2 mm).

5.2.2.1 Type ZHC anodes designated as shown on Fig. 6 and Fig. 8 and are intended for use with rubber washers for submarine application. The countersink for the rubber washer may be cast or machined. The anode shall be manufactured so that the countersink is centered on the core hole and the rubber washer fits snugly between the hull and anode core to prevent anode movement or vibration.

5.2.2.2 Type ZSS, ZHS, ZHB, and ZTS anodes may be mounted by welding or by fasteners. Those intended to be attached by fasteners shall indicate the requirements for mounting holes in the strap. The mounting hole shall be counterbored on the structure side of the strap.

5.2.3 The pipe core inserts for Type ZEP anodes shall conform to 5.1.3. The position of the pipe core insert shall not vary more than $\pm 1/8$ in. (3 mm) from the center as shown on Fig. 1.

5.2.4 The position of the pipe core insert for Type ZBP anodes specified in 5.1.3 shall not vary more than $\pm 1/4$ in. (6 mm) from the center as shown on Fig. 12.

5.2.5 Metallic bonding or an interference fit of the core into

Type ZDM anode (see Fig. 2) shall be required so that an axial force applied from the stud end to remove the core insert is a minimum of 750 lb (340 kg) (see 13.1.3).

5.2.6 The machine formed core insert specified in 5.1.4 shall be manufactured in accordance with details and tolerances shown for Piece 2 on Fig. 1 and ANSI/ASME B1.20.1.

5.2.6.1 The pieces shown on Fig. 1 shall screw together very snugly by hand tightening or by using simple hand tools such as pliers or pipe wrenches.

6. Chemical Composition

6.1 The anodes shall conform to the composition specified in Table 1. Total of elemental constituents not specified in Table 1 shall not exceed 0.10%. Metallic elements not specified in Table 1 are considered contaminants.

7. Mechanical Properties

7.1 When tested in accordance with 13.2, Types ZRN rods and ZPN plates shall not fracture or show signs of cracking.

7.2 When tested in accordance with 13.2.1, ZRN anodes shall have a minimum torsional shear strength of 12 000 psi (83 MPa).

8. Other Requirements

8.1 When tested in accordance with 13.1.1 or 13.1.2, Types

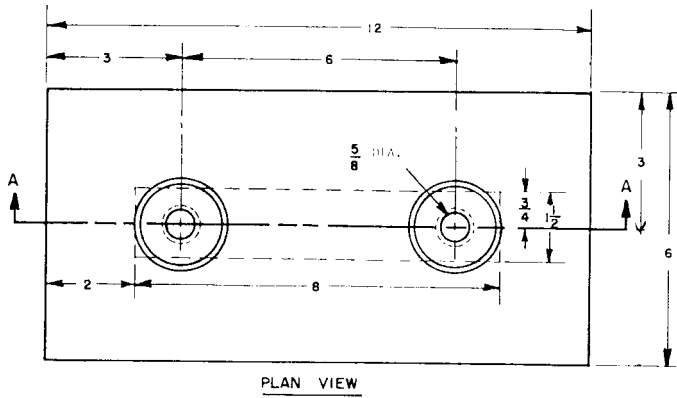

PLAN VIEW

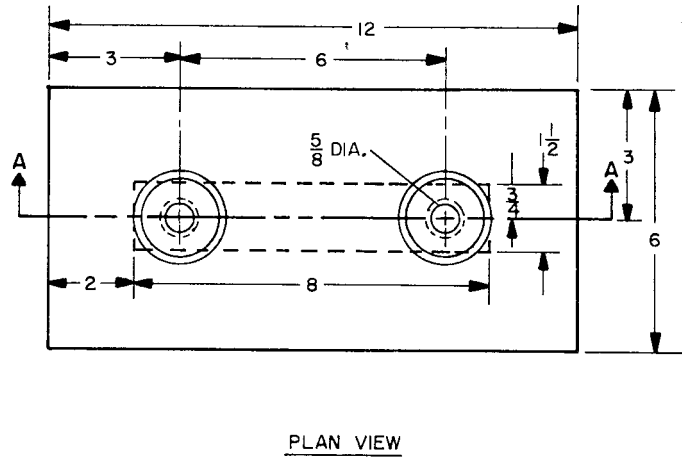

PLAN VIEW

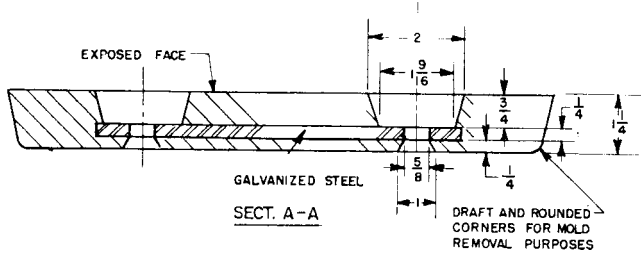

SECT. A-A

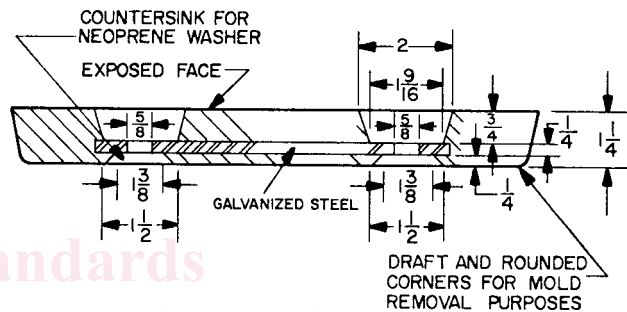

SECTION A-A

- NOTE 1—Anode may be cast with exposed face in the up or down position. All dimensions are in inches.
- NOTE 2—Tolerance $\pm 1/8$ in.
- NOTE 3—1 in. = 25.4 mm.
- NOTE 4—Minimum weight 21.5 lb (9.7 kg).

FIG. 5 Zinc Hull Slab (Core Strap), Type ZHC-23

- NOTE 1—Anode may be cast with exposed face in the up or down position. All dimensions are in inches.
- NOTE 2—Tolerance $\pm 1/8$ in.
- NOTE 3—1 in. = 25.4 mm.
- NOTE 4—Minimum weight 21.5 lb (9.7 kg).

FIG. 6 Zinc Hull Slab (Core Strap), Type ZHC-23, Submarine Application

ZHS, ZHB, ZHC, ZSS, ZTS, ZEP, and ZBP anodes shall obtain a sound metallurgical bond between the zinc and core for at least 30 % of the total surface area of each core in contact with the anode.

8.2 During the manufacturing process, certain toxic compounds (such as zinc phosphide) may become by-products. Caution should be taken in disposal of process wastewater to ensure that the composition of the water meets with local, state, and federal regulations.

9. Dimensions, Mass, and Permissible Variations

9.1 Types ZHS, ZHB, ZHC, ZTS, ZSS, ZEP, ZBP, ZDM, and ZRN anodes shall be in accordance with the dimensions shown in Figs. 1-11, inclusive.

9.2 Type ZPN anode shall be 48 in. (1220 mm) in length by 24 in. (610 cm) in width.

9.2.1 The thickness shall be either 1/2 or 1 in. (13 or 25 mm) as specified (see 4.1.10).

9.3 Types ZSS-12, ZSS-24, ZHC-23, ZHC-42, ZHS-23, and ZHS-42 shall have the following minimum weight requirements:

Anode	Weight, min, lb (kg)
ZSS-12	11.0 (5)
ZSS-24, ZHC-23, ZHS-23	21.5 (10)
ZHC-42	39.0 (18)
ZHS-42	41.0 (19)

9.3.1 The total weight of the specified type of anode received divided by the total number of anodes of that type shall be equal to or greater than the minimum weight (11.0, 21.5, 39.0, 41.0 lb (5, 10, 18, 19 kg)) of the anode type

specified. If the weight is less than the minimum weight for the type of anode specified, it shall be cause for rejection of the entire lot.

9.4 The length and width of Types ZHS, ZHB, ZHC, ZTS, ZPN, ZSS, and ZBP anodes shall not vary more than $\pm 1/8$ in. (3 mm), measured at the widest surface of the tapered (for mold release) anode.

9.5 The length of Type ZRN anodes will be permitted to have a variation of ± 1 in. (25 mm) based on nominal lengths of 3 and 6 ft (914 and 1829 mm).

9.6 The diameter or width, whichever is the larger, of Type ZEP anodes shall not vary from the specified dimension by more than $\pm 1/8$ in. (3 mm).

9.7 The diameter of Type ZDM anodes shall not vary more than +0.025 in. (1 mm) or -0.005 in. (0.13 mm) from the specified diameter.

9.8 The diameter of the ZRN anode shall not vary more than $\pm 1/32$ in. (1 mm) from the specified diameter.

9.9 The thickness of Types ZHS, ZHB, ZHC, ZTS, ZPN, ZSS, ZEP, and ZBP anodes shall not vary more than $\pm 1/8$ in. (3 mm). Thickness measurements shall be taken at random 1 in. (25 mm) from any edge of the anode by means of a suitable

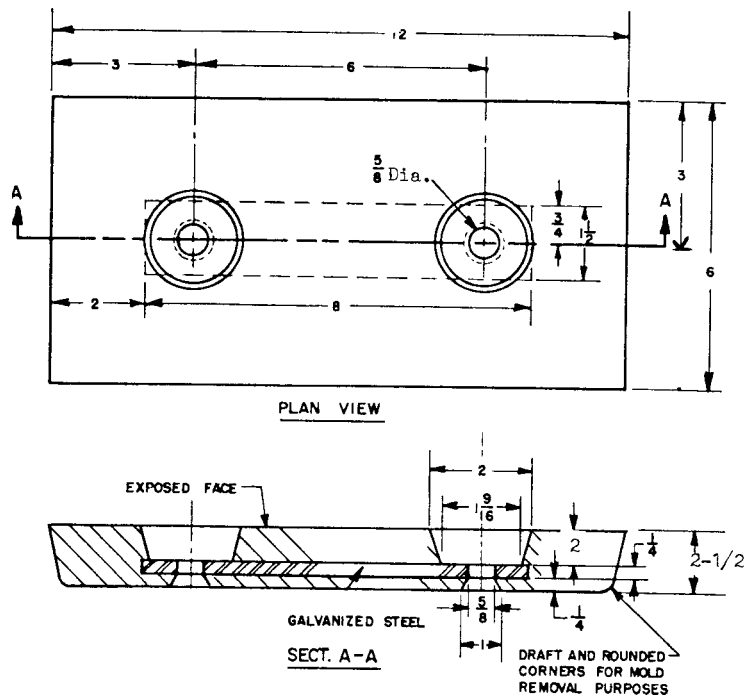

- NOTE 1—Anode may be cast with exposed face in the up or down position. All dimensions are in inches.
 NOTE 2—Tolerance $\pm 1/8$ in.
 NOTE 3—1 in. = 25.4 mm.
 NOTE 4—Minimum weight 39 lb (17.7 kg).

FIG. 7 Zinc Hull Slab (Core Strap), Type ZHC-42

caliper avoiding any surface irregularities which would interfere with a representative measurement.

9.10 The thickness of Type ZDN anodes shall not vary more than $\pm 1/64$ in. (0.4 mm).

9.10.1 The cores of Type ZDM anodes shall be positioned axially and concentrically in the zinc disc. Eccentricity greater than 0.005 in. (0.13 mm) will not be permitted.

10. Workmanship, Finish, and Appearance

10.1 The zinc anodes shall be free of flash burrs, cracks, blow holes, pipes, and surface slag consistent with good commercial practice.

10.1.1 For anodes less than 2 in. (50 mm) thick, when measured with a straightedge placed diagonally across the opposite edges of the cast anode, the anode shall be free of shrinkage cavities exceeding $1/4$ in. (6 mm) in depth. Anodes 2 in. (50 mm) thick or more shall be free of shrinkage cavities exceeding $3/8$ in. (10 mm) in depth.

10.1.1.1 For Type ZPN anodes, shrinkage cavities shall be measured over a 12- by 12-in. (305- by 305-mm) area and shall not exceed the dimensions specified in 10.1.1.

10.1.2 Surface irregularities of the anode exceeding $1/8$ in. (3 mm) in depth shall not be permitted on either face of slab or disc type anodes unless at least $1/8$ in. (3 mm) of sound metal covers the entire strap of core area.

10.2 Types ZDM and ZRN anodes shall be smooth on their curved surfaces.

10.3 Metal core extensions from the anodes shall be smooth and free of sharp burrs. The cast-in cores shall have metallurgical bonds specified herein free of air pockets and inclusions

consistent with good commercial practice.

10.4 The coatings specified in 5.1.1 shall be adherent and free from flaking. The coating shall adhere tenaciously to the surface of the base metal. When the coating is cut or pried into, such as with a stout knife applied with considerable pressure in a manner tending to remove a portion of the coating, it shall only be possible to remove small particles of the coating by paring or whittling, and it shall not be possible to peel any portion of the coating so as to expose the steel. Lack of adhesion of the zinc coating at bends or absence of zinc coating at cut edges shall not be cause for rejection of fabricated anodes.

11. Sampling

11.1 For the purposes of sampling, a lot shall consist of all zinc anodes of the same class and type, poured or cast from one homogeneous heat or melt of a single charge of raw materials. The addition of any material to the heat or melt at any time constitutes a new lot.

11.2 Select a random sample of anodes from each lot in accordance with MIL-STD-105 at Inspection Level II for the examination specified in 14.1. In terms of defects per 100 units, the acceptable quality level (AQL) shall be 4.0 for total defects.

11.3 From each lot specified in 11.1, select two anodes at random of Types ZHS, ZHB, ZHC, ZSS, ZTS, ZEP, and ZBP and five anode discs of Type ZDM for the core bond tests specified in 13.1.1 or 13.1.2.

11.3.1 In cases in which one of the two anodes specified in 13.1.1 or 13.1.2 fails to pass the bond test, select four additional anodes for retest at the request of the manufacturer.