

# INTERNATIONAL STANDARD

## NORME INTERNATIONALE

**Digital audio – Interface for non-linear PCM encoded audio bitstreams applying IEC 60958 – Part 3: Non-linear PCM bitstreams according to the AC-3 and enhanced AC-3 formats**

**Audionumérique – Interface pour les flux de bits audio à codage MIC non linéaire conformément à la CEI 60958 –**

**Partie 3: Flux de bits MIC non linéaire selon les formats AC-3 et AC-3 amélioré**



**THIS PUBLICATION IS COPYRIGHT PROTECTED**  
**Copyright © 2007 IEC, Geneva, Switzerland**

All rights reserved. Unless otherwise specified, no part of this publication may be reproduced or utilized in any form or by any means, electronic or mechanical, including photocopying and microfilm, without permission in writing from either IEC or IEC's member National Committee in the country of the requester.  
If you have any questions about IEC copyright or have an enquiry about obtaining additional rights to this publication, please contact the address below or your local IEC member National Committee for further information.

Droits de reproduction réservés. Sauf indication contraire, aucune partie de cette publication ne peut être reproduite ni utilisée sous quelque forme que ce soit et par aucun procédé, électronique ou mécanique, y compris la photocopie et les microfilms, sans l'accord écrit de la CEI ou du Comité national de la CEI du pays du demandeur.  
Si vous avez des questions sur le copyright de la CEI ou si vous désirez obtenir des droits supplémentaires sur cette publication, utilisez les coordonnées ci-après ou contactez le Comité national de la CEI de votre pays de résidence.

IEC Central Office  
3, rue de Varembe  
CH-1211 Geneva 20  
Switzerland

Tel.: +41 22 919 02 11  
Fax: +41 22 919 03 00  
[info@iec.ch](mailto:info@iec.ch)  
[www.iec.ch](http://www.iec.ch)

### About the IEC

The International Electrotechnical Commission (IEC) is the leading global organization that prepares and publishes International Standards for all electrical, electronic and related technologies.

### About IEC publications

The technical content of IEC publications is kept under constant review by the IEC. Please make sure that you have the latest edition, a corrigenda or an amendment might have been published.

#### Useful links:

IEC publications search - [www.iec.ch/searchpub](http://www.iec.ch/searchpub)

The advanced search enables you to find IEC publications by a variety of criteria (reference number, text, technical committee,...).

It also gives information on projects, replaced and withdrawn publications.

IEC Just Published - [webstore.iec.ch/justpublished](http://webstore.iec.ch/justpublished)

Stay up to date on all new IEC publications. Just Published details all new publications released. Available on-line and also once a month by email.

Electropedia - [www.electropedia.org](http://www.electropedia.org)

The world's leading online dictionary of electronic and electrical terms containing more than 30 000 terms and definitions in English and French, with equivalent terms in additional languages. Also known as the International Electrotechnical Vocabulary (IEV) on-line.

Customer Service Centre - [webstore.iec.ch/csc](http://webstore.iec.ch/csc)

If you wish to give us your feedback on this publication or need further assistance, please contact the Customer Service Centre: [csc@iec.ch](mailto:csc@iec.ch).

### A propos de la CEI

La Commission Electrotechnique Internationale (CEI) est la première organisation mondiale qui élabore et publie des Normes internationales pour tout ce qui a trait à l'électricité, à l'électronique et aux technologies apparentées.

### A propos des publications CEI

Le contenu technique des publications de la CEI est constamment revu. Veuillez vous assurer que vous possédez l'édition la plus récente, un corrigendum ou amendement peut avoir été publié.

#### Liens utiles:

Recherche de publications CEI - [www.iec.ch/searchpub](http://www.iec.ch/searchpub)

La recherche avancée vous permet de trouver des publications CEI en utilisant différents critères (numéro de référence, texte, comité d'études,...).

Elle donne aussi des informations sur les projets et les publications remplacées ou retirées.

Just Published CEI - [webstore.iec.ch/justpublished](http://webstore.iec.ch/justpublished)

Restez informé sur les nouvelles publications de la CEI. Just Published détaille les nouvelles publications parues. Disponible en ligne et aussi une fois par mois par email.

Electropedia - [www.electropedia.org](http://www.electropedia.org)

Le premier dictionnaire en ligne au monde de termes électroniques et électriques. Il contient plus de 30 000 termes et définitions en anglais et en français, ainsi que les termes équivalents dans les langues additionnelles. Egalement appelé Vocabulaire Electrotechnique International (VEI) en ligne.

Service Clients - [webstore.iec.ch/csc](http://webstore.iec.ch/csc)

Si vous désirez nous donner des commentaires sur cette publication ou si vous avez des questions contactez-nous: [csc@iec.ch](mailto:csc@iec.ch).

# INTERNATIONAL STANDARD

## NORME INTERNATIONALE

**Digital audio – Interface for non-linear PCM encoded audio bitstreams applying IEC 60958 – Part 3: Non-linear PCM bitstreams according to the AC-3 and enhanced AC-3 formats**

**Audionumérique – Interface pour les flux de bits audio à codage MIC non linéaire conformément à la CEI 60958 –**

**Partie 3: Flux de bits MIC non linéaire selon les formats AC-3 et AC-3 amélioré**

INTERNATIONAL  
ELECTROTECHNICAL  
COMMISSION

COMMISSION  
ELECTROTECHNIQUE  
INTERNATIONALE

ICS 33.160.30

ISBN 978-2-83220-522-8

**Warning! Make sure that you obtained this publication from an authorized distributor.  
Attention! Veuillez vous assurer que vous avez obtenu cette publication via un distributeur agréé.**

## CONTENTS

FOREWORD.....	3
1 Scope.....	5
2 Normative references.....	5
3 Terms, definitions and abbreviations.....	5
3.1 Terms and definitions.....	5
3.2 Abbreviations.....	6
4 Mapping of the audio bitstream on to IEC 61937-1.....	6
4.1 General.....	6
4.2 AC-3 and enhanced AC-3 burst-info.....	6
5 Format of AC-3 and enhanced AC-3 data-bursts.....	6
5.1 General.....	6
5.2 Pause data-burst.....	7
5.3 Audio data-bursts.....	7
5.3.1 AC-3 data.....	7
5.3.2 Latency of AC-3 decoding.....	8
5.3.3 Enhanced AC-3 data.....	9
5.3.4 Latency of the enhanced AC-3 decoder.....	10
Bibliography.....	13
Figure 1 – AC-3 data-burst, with reference point R.....	7
Figure 2 – Latency of AC-3 decoding.....	8
Figure 3 – Enhanced AC-3 data-burst.....	10
Figure 4 – Latency of enhanced AC-3 decoding.....	11
Table 1 – Fields of burst-info.....	6
Table 2 – Repetition period of the pause data-bursts.....	7
Table 3 – Data-type-dependent information when data-type = 1.....	7
Table 4 – Data-type-dependent information when data-type = 21.....	10
Table 5 – Frame repetition period and maximum data rate for enhanced AC-3 bitstreams.....	10

## INTERNATIONAL ELECTROTECHNICAL COMMISSION

**DIGITAL AUDIO –  
INTERFACE FOR NON-LINEAR PCM ENCODED  
AUDIO BITSTREAMS APPLYING IEC 60958 –****Part 3: Non-linear PCM bitstreams according to  
the AC-3 and enhanced AC-3 formats**

## FOREWORD

- 1) The International Electrotechnical Commission (IEC) is a worldwide organization for standardization comprising all national electrotechnical committees (IEC National Committees). The object of IEC is to promote international co-operation on all questions concerning standardization in the electrical and electronic fields. To this end and in addition to other activities, IEC publishes International Standards, Technical Specifications, Technical Reports, Publicly Available Specifications (PAS) and Guides (hereafter referred to as "IEC Publication(s)"). Their preparation is entrusted to technical committees; any IEC National Committee interested in the subject dealt with may participate in this preparatory work. International, governmental and non-governmental organizations liaising with the IEC also participate in this preparation. IEC collaborates closely with the International Organization for Standardization (ISO) in accordance with conditions determined by agreement between the two organizations.
- 2) The formal decisions or agreements of IEC on technical matters express, as nearly as possible, an international consensus of opinion on the relevant subjects since each technical committee has representation from all interested IEC National Committees.
- 3) IEC Publications have the form of recommendations for international use and are accepted by IEC National Committees in that sense. While all reasonable efforts are made to ensure that the technical content of IEC Publications is accurate, IEC cannot be held responsible for the way in which they are used or for any misinterpretation by any end user.
- 4) In order to promote international uniformity, IEC National Committees undertake to apply IEC Publications transparently to the maximum extent possible in their national and regional publications. Any divergence between any IEC Publication and the corresponding national or regional publication shall be clearly indicated in the latter.
- 5) IEC provides no marking procedure to indicate its approval and cannot be rendered responsible for any equipment declared to be in conformity with an IEC Publication.
- 6) All users should ensure that they have the latest edition of this publication.
- 7) No liability shall attach to IEC or its directors, employees, servants or agents including individual experts and members of its technical committees and IEC National Committees for any personal injury, property damage or other damage of any nature whatsoever, whether direct or indirect, or for costs (including legal fees) and expenses arising out of the publication, use of, or reliance upon, this IEC Publication or any other IEC Publications.
- 8) Attention is drawn to the Normative references cited in this publication. Use of the referenced publications is indispensable for the correct application of this publication.
- 9) Attention is drawn to the possibility that some of the elements of this IEC Publication may be the subject of patent rights. IEC shall not be held responsible for identifying any or all such patent rights.

International Standard IEC 61937-3 has been prepared by technical area 4: Digital system interfaces, of IEC technical committee 100: Audio, video and multimedia systems and equipment.

This second edition of IEC 61937-3 cancels and replaces the first edition published in 2003. This edition contains the following significant technical changes with respect to the previous edition.

- a) The definition of the audio data-burst required to deliver enhanced AC-3 bitstreams has been added.
- b) The definition of the latency of an enhanced AC-3 decoder has been added.
- c) The use of pause data-bursts when delivering enhanced AC-3 bitstreams has been added.

This bilingual version (2012-12) corresponds to the monolingual English version, published in 2007-11. The text of this standard is based on the following documents:

CDV	Report on voting
100/1207/CDV	100/1291/RVC

Full information on the voting for the approval of this standard can be found in the report on voting indicated in the above table.

The French version of this standard has not been voted upon.

This publication has been drafted in accordance with the ISO/IEC Directives, Part 2.

The list of all the parts of the IEC 61937 series, under the general title *Digital audio – Interface for non-linear PCM encoded audio bitstreams applying IEC 60958*, can be found on the IEC website.

The committee has decided that the contents of this publication will remain unchanged until the maintenance result date indicated on the IEC web site under "<http://webstore.iec.ch>" in the data related to the specific publication. At this date, the publication will be

- reconfirmed,
- withdrawn,
- replaced by a revised edition, or
- amended.

ITeH Standards  
(<https://standards.iteh.ai>)  
Document Preview

[IEC 61937-3:2007](https://standards.iteh.ai/standards/iec/61937-3-2007)

<https://standards.iteh.ai/standards/iec/61937-3-2007>

# DIGITAL AUDIO – INTERFACE FOR NON-LINEAR PCM ENCODED AUDIO BITSTREAMS APPLYING IEC 60958 –

## Part 3: Non-linear PCM bitstreams according to the AC-3 and enhanced AC-3 formats

### 1 Scope

This part of IEC 61937 describes the method used to convey non-linear PCM bitstreams encoded according to the AC-3 and enhanced AC-3 formats.

### 2 Normative references

The following referenced documents are indispensable for the application of this document. For dated references, only the edition cited applies. For undated references, the latest edition of the referenced document (including any amendments) applies.

IEC 60958 (all parts), *Digital audio interface*

IEC 61937-1:2007, *Digital audio interface for non-linear PCM encoded audio bitstreams applying IEC 60958 – Part 1: General*

IEC 61937-2:2007, *Digital audio interface for non-linear PCM encoded audio bitstreams applying IEC 60958 – Part 2: Burst-info*

ATSC Standard A/52B, *Digital Audio Compression (AC-3, E-AC-3), Rev. B*

ETSI TS 102 366, *Digital Audio Compression (AC-3, Enhanced AC-3)*

### 3 Terms and definitions

For the purposes of this standard, the following terms, definitions and abbreviations apply.

#### 3.1 Terms and definitions

##### 3.1.1

##### **latency**

delay time of an external audio decoder to decode an AC-3 or enhanced AC-3 data burst, defined as the sum of two values of the receiving delay time and the decoding delay time

##### 3.1.2

##### **stream type**

an enhanced AC-3 bitstream is constructed from one or more substreams, with each substream being constructed from a sequence of frames. The stream type parameter of an enhanced AC-3 frame identifies the type of substream of which the frame is a part

### 3.1.3

#### substream identification

substream identification parameter of an enhanced AC-3 frame which, in conjunction with the stream type parameter, identifies the substream in the bitstream of which the enhanced AC-3 frame is a part

### 3.1.4

#### converter synchronization flag

flag used for synchronization by a device that converts an enhanced AC-3 bitstream to a bitstream compliant with an AC-3 decoder and indicates that the first block in this enhanced AC-3 frame will form the first block of the AC-3 frame output by the conversion process

### 3.1.5

#### block identification flag

if the stream type value of an enhanced AC-3 substream is two, indicating that the bitstream has been converted from an AC-3 bitstream, this bit is set to 1 to indicate that the first block in this enhanced AC-3 frame was the first block in the original standard AC-3 frame

## 3.2 Abbreviations

ATSC	Advanced Television Standards Committee
ETSI	European Telecommunication Standards Institute
IEC	International Electrotechnical Commission
ISO/IEC MPEG	Moving Pictures Expert Group, a joint committee of ISO and IEC

## 4 Mapping of the audio bitstream on to IEC 61937-1

### 4.1 General

The coding of the bitstream and data-burst is in accordance with IEC 61937-1 and 61937-2.

### 4.2 AC-3 and enhanced AC-3 burst-info

The 16-bit burst-info contains information about the data which will be found in the data-burst (see Table 1).

**Table 1 – Fields of burst-info**

Data-type	Sub-data-type	Contents	Reference point R	Repetition period of data-burst measured in IEC 60958 frames
Value of Pc bits 0-4	Value of Pc bits 5-6			
1	0	AC-3	R-AC-3	1 536
21	0	Enhanced AC-3	Bit 0 of Pa	6 144
	1-3	Reserved	Reserved	Reserved

## 5 Format of AC-3 and enhanced AC-3 data-bursts

### 5.1 General

This clause specifies the audio data-bursts AC-3 and enhanced AC-3. Specific properties such as reference points, repetition periods, the method of filling stream gaps, and decoding latency are specified.



The decoding latency (or delay), indicated for the data-type, should be used by the transmitter to schedule data-bursts as necessary to establish synchronization between picture and decoded audio.

## 5.2 Pause data-burst

Pause data-bursts for AC-3 and enhanced AC-3 are given in Table 2.

**Table 2 – Repetition period of the pause data-bursts**

Data-type of audio data-burst	Repetition period of pause data-burst	
	Mandatory	Recommended
AC-3	-	3 IEC 60958 frames
Enhanced AC-3	-	4 IEC 60958 frames

## 5.3 Audio data-bursts

### 5.3.1 AC-3 data

The AC-3 bitstream consists of a sequence of AC-3 frames. The data-type of an AC-3 data-burst is 1. An AC-3 frame represents 1 536 samples of each encoded audio channel (left, centre, etc.). The data-burst is headed with a burst-preamble followed by the burst-payload. The burst-payload of each data burst of AC-3 data shall contain one complete AC-3 frame. Figure 1 shows the structure of the AC-3 data-burst.

The length of the AC-3 data-burst will depend on the encoded bit rate (which determines the AC-3 frame length). The specification for the AC-3 bitstream may be found in ATSC Standard A52/B or in ETSI TS 102 366.

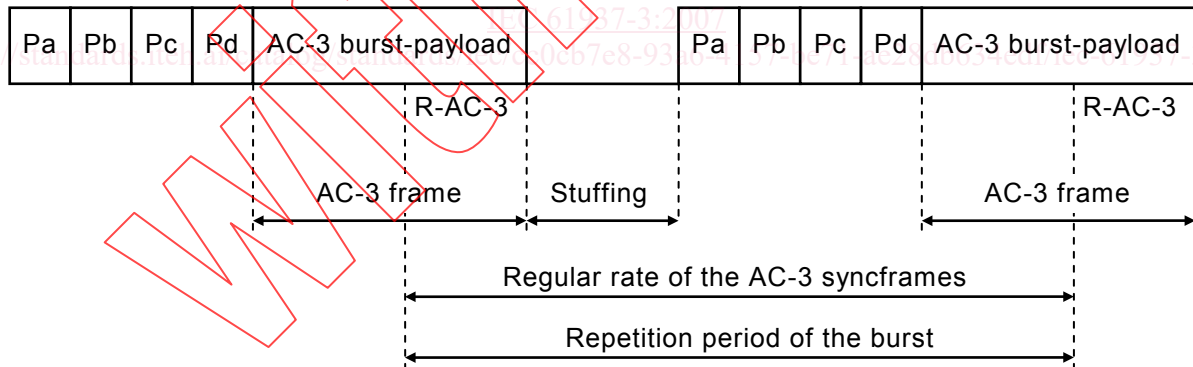

**Figure 1 – AC-3 data-burst, with reference point R**

The data-type-dependent info for AC-3 is given in Table 3.

**Table 3 – Data-type-dependent information when data-type = 1**

Bits of Pc LSB..MSB	Data type dependent, bit number LSB...MSB	Contents
8-10	0-2	Value of 'bsmod' parameter in AC-3 elementary stream
11, 12	3-4	Reserved

The data-bursts containing AC-3 frames shall occur at a regular rate, with the reference point of each AC-3 data-burst beginning (except in the case of a gap) 1 536 sampling periods of the audio after the reference point of the preceding AC-3 data burst (of the same bitstream number).

The reference point of an AC-3 data-burst (R-AC-3) is the IEC 60958 frame that occurs two-thirds of the way through the AC-3 payload. The definition of the two-thirds value is the closest integer to the value of the AC-3 frame size measured in 32-bit words multiplied by the value 2/3, or

$$2/3 \text{ frame size} = \text{int} (0,5 + (2/3) \times (\text{frame size in 32-bit words}))$$

### 5.3.2 Latency of AC-3 decoding

The latency of an AC-3 decoder which receives this signal is specified, with respect to the reference point of the AC-3 burst, to be equal to one AC-3 block time, which is equal to the time occupied by 256 PCM samples at the encoded sampling frequency (5,33 ms for 48 kHz sampling frequency; see Figure 2).

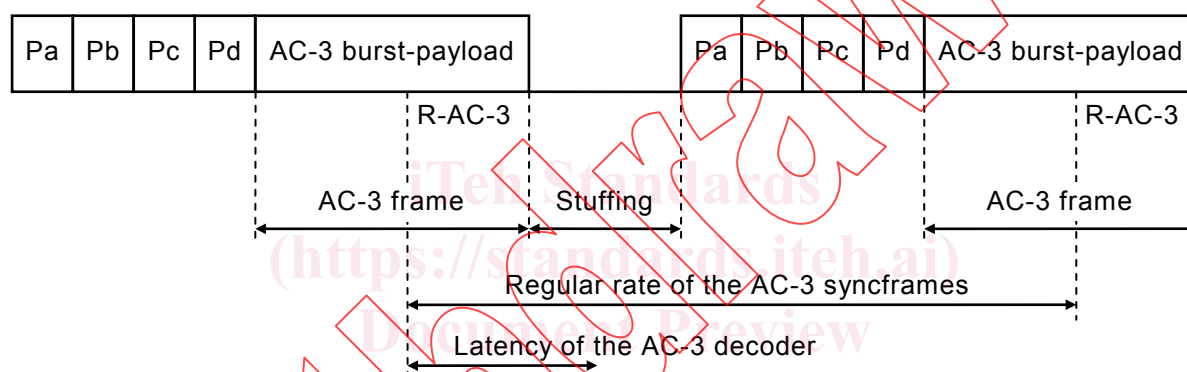

**Figure 2 – Latency of AC-3 decoding**

It is recommended that pause data-bursts be used to fill stream gaps in the AC-3 bitstream, as described in IEC 61937-1, and that pause data-bursts be transmitted with a repetition period of three IEC 60958 frames, except when other repetition periods are necessary to fill the precise stream gap length (which may not be a multiple of three IEC 60958 frames), or to meet the requirement on burst spacing (see IEC 61937-1, 6.3.3).

When a stream gap in an AC-3 stream is filled by a sequence of pause data-bursts, the Pa of the first pause data-burst shall be located one frame repetition period following the Pa of the previous AC-3 frame. It is recommended that the sequence(s) of pause data-bursts which fill the stream gap should continue from this point up to (as close as possible considering the three IEC 60958 frame length of the pause data-burst) the Pa of the first AC-3 data-burst which follows the stream gap.

The gap length parameter contained in the pause data-burst is intended to be interpreted by the AC-3 decoder as an indication of the number of decoded PCM samples which are missing (due to the resulting audio gap). If the sizes of the AC-3 frames before and after the stream gap are not equal (due to a bitrate change in the interrupted AC-3 bitstream), this value may differ from the actual number of sampling periods of the audio contained in the stream gap due to the definition of the AC-3 burst reference points.

Some AC-3 decoders may be capable of “concealing” audio gaps. The indication of the audio gap length (gap-length) which may be included in the payload of the pause data-burst allows the decoder to know how long an audio gap will need to be concealed, and thus allow the decoder to optimize the concealment process for the actual audio gap length. AC-3 decoders will most easily conceal audio gaps that have a length equal to an integral multiple of 256

samples. Thus, audio gaps of lengths 256, 512, 768, etc. sampling periods of the audio are strongly preferred, and transmitters should provide stream gaps that represent audio gaps with this granularity.

It is possible that an audio gap in an AC-3 stream is carried over this interface without there also being a stream gap. This can happen when the audio gap length is small and there is a bit rate change in the interrupted AC-3 bit stream, and the bit rate following the gap is larger than the bit rate prior to the gap. Because of the definition of the reference point of the AC-3 data burst, it is possible for the Pa of the first burst following a bitstream interruption to be less than frame repetition period of the audio following the Pa of the burst preceding the gap, while the reference point of the first burst following the bit stream interruption is more than one frame repetition period of the audio after the reference point of the burst preceding the gap. When this case occurs, since there is no stream gap to fill with pause bursts, there is no need to send any pause bursts. The audio decoder will never be starved for data and can calculate the length of the audio gap based on the reference points of the received AC-3 bursts.

### 5.3.3 Enhanced AC-3 data

An enhanced AC-3 bitstream is constructed from one or more substreams, with each substream being constructed from a sequence of enhanced AC-3 frames. An enhanced AC-3 frame is constructed from blocks of audio data, each block representing 256 samples of audio of each encoded audio channel (left, centre, etc.). An enhanced AC-3 frame can consist of one, two, three, or six blocks of audio data. The number of blocks per enhanced AC-3 frame is the same for all substreams present in the bitstream and is constant for the duration of the bitstream.

The data-burst is headed with a burst-preamble, followed by the burst-payload. The data-type of an enhanced AC-3 data-burst is 21, and the sub-data-type is 0. When enhanced AC-3 data is being transmitted, the transmission device shall ensure that both the data-type and sub-data-type values are set correctly. Additionally, the receiving device shall utilize both the data-type and sub-data-type values to ensure that the content of the data-burst is correctly identified as enhanced AC-3. The structure of the enhanced AC-3 data-burst is shown in Figure 3.

The enhanced AC-3 burst-payload shall always contain six blocks of coded audio data, representing 1 536 samples of PCM audio, from each of the substreams present in the bitstream. The transmission device shall ensure that the enhanced AC-3 burst-payload is constructed only from complete enhanced AC-3 frames. It is prohibited to transmit a single enhanced AC-3 frame using multiple data-bursts.

The transmission device shall ensure that the first enhanced AC-3 frame in the burst-payload is the frame that has a stream type value of zero or two, and a substream identification value of zero. When the enhanced AC-3 bitstream is constructed from frames that consist of six blocks of audio data, one frame from each substream present in the bitstream shall be included in the burst-payload.

When the enhanced AC-3 bitstream is constructed from frames that consist of less than six blocks of audio, the transmission device shall ensure that the burst-payload contains the number of enhanced AC-3 frames required to deliver six blocks of audio data from each substream in the bitstream. For example, when the bitstream is constructed from frames that consist of two blocks of audio data, the burst-payload shall contain three enhanced AC-3 frames from each substream in the bitstream. Additionally, when the number of blocks per frame is less than six, the transmission device shall ensure that when the first substream in the bitstream has a stream type value of zero, the first frame in the burst-payload shall be the frame where the converter synchronization flag is set to one. When the first substream in the bitstream has a stream type value of two, the first frame in the burst-payload shall be the frame where the block identification flag is set to one.

The length of the enhanced AC-3 data-burst will depend on the encoded bit rate (which determines the enhanced AC-3 frame length). The specification for the enhanced AC-3 bitstream may be found in ATSC Standard A/52B or in ETSI TS 102 366.