

INTERNATIONAL STANDARD

ISO 8470

First edition
1990-09-01

AMENDMENT 1
1993-01-15

Road vehicles – M14 × 1,25 spark-plugs with flat seating and 16 mm hexagon and their cylinder head housing

iTeh STANDARD PREVIEW
AMENDMENT 1
(standards.iteh.ai)

Véhicules routiers – Bougies d'allumage M14 × 1,25 à siège plat et à hexagone de 16 mm et leur logement dans la culasse
<https://standards.iteh.ai/catalog/standards/sist/4ca68554-ca69-45fa-b7d4-6ab5543614e/iso-8470-1990-amd-1-1993>
AMENDEMENT 1



Reference number
ISO 8470:1990/Amd.1:1993 (E)

Foreword

ISO (the International Organization for Standardization) is a worldwide federation of national standards bodies (ISO member bodies). The work of preparing International Standards is normally carried out through ISO technical committees. Each member body interested in a subject for which a technical committee has been established has the right to be represented on that committee. International organizations, governmental and non-governmental, in liaison with ISO, also take part in the work. ISO collaborates closely with the International Electrotechnical Commission (IEC) on all matters of electrotechnical standardization.

Draft International Standards adopted by the technical committees are circulated to the member bodies for voting. Publication as an International Standard requires approval by at least 75 % of the member bodies casting a vote.

Amendment 1 to International Standard ISO 8470:1990 was prepared by Technical Committee ISO/TC 22, *Road vehicles*, Sub-Committee SC 1, *Ignition equipment*.

[ISO 8470:1990/Amd 1:1993](https://standards.iteh.ai/catalog/standards/sist/dea68334-ca69-45fa-b7d4-6ab554361f4e/iso-8470-1990-amd-1-1993)

<https://standards.iteh.ai/catalog/standards/sist/dea68334-ca69-45fa-b7d4-6ab554361f4e/iso-8470-1990-amd-1-1993>

© ISO 1993

All rights reserved. No part of this publication may be reproduced or utilized in any form or by any means, electronic or mechanical, including photocopying and microfilm, without permission in writing from the publisher.

International Organization for Standardization
Case postale 56 • CH-1211 Genève 20 • Switzerland

Printed in Switzerland

Road vehicles – M14 × 1,25 spark-plugs with flat seating and 16 mm hexagon and their cylinder head housing

AMENDMENT 1

iTeh STANDARD PREVIEW
(standards.iteh.ai)

Page 1, subclause 3.1

<https://standards.iteh.ai/catalog/standards/si/601591574462513619811701199011993>

The second sentence of this subclause is changed to indicate clearly that not only the nut but the whole spark-plug shall respect the dimensions specified for spark-plugs with solid post terminal.

3.1 Terminals

The spark-plug terminal may be either the solid post or the threaded type. A spark-plug with threaded terminal on which a nut is applied shall respect the dimensions specified for spark-plugs with solid post terminal (see figure 1).

Page 3, figure 1

Replace the existing figure 1 with the following figure which has an additional length dimension, the minimum insulator length, which is 34 mm for spark-plugs with solid post terminal and 31 mm for spark-plugs with threaded terminal.

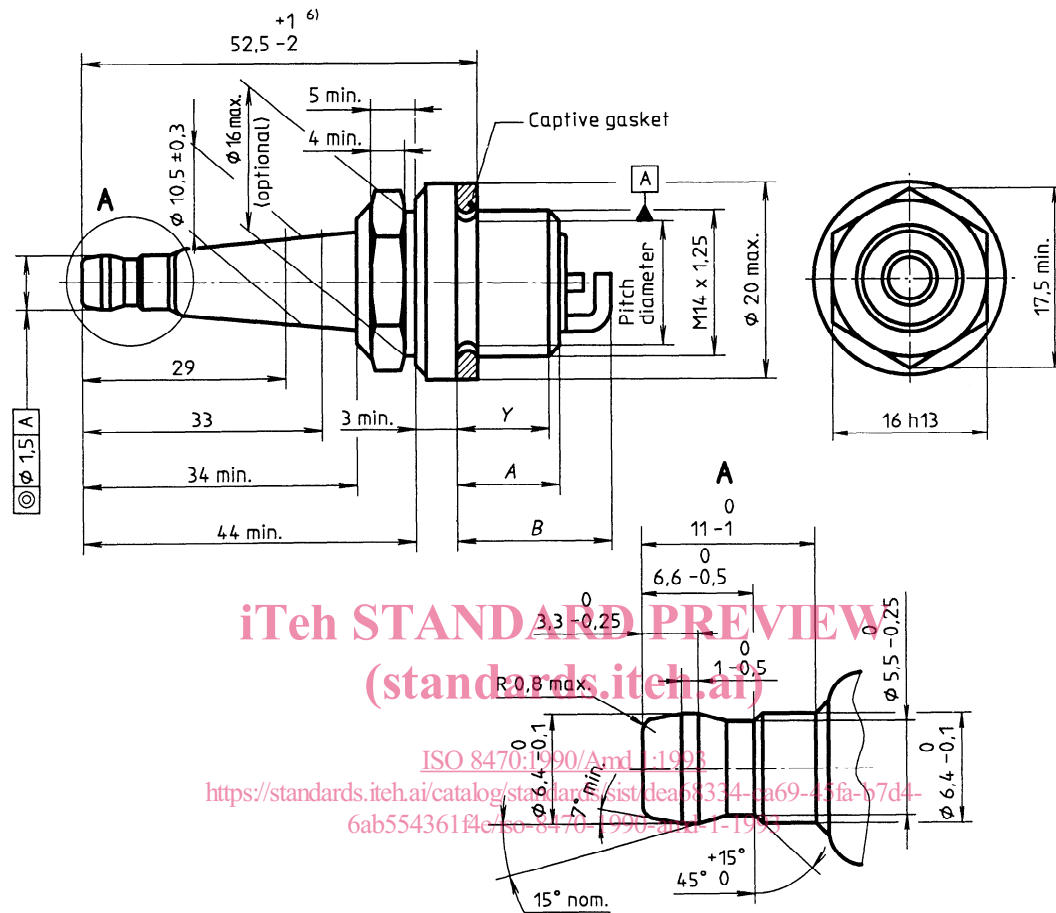

iTeh STANDARD PREVIEW
(standards.iteh.ai)

ISO 8470:1990/Amd.1:1993
<https://standards.iteh.ai/catalog/standards/sist/da68334-ca69-43fa-b7d4-6ab554361f4c/iso-8470-1990-amd-1-1993>

a) With solid post terminal

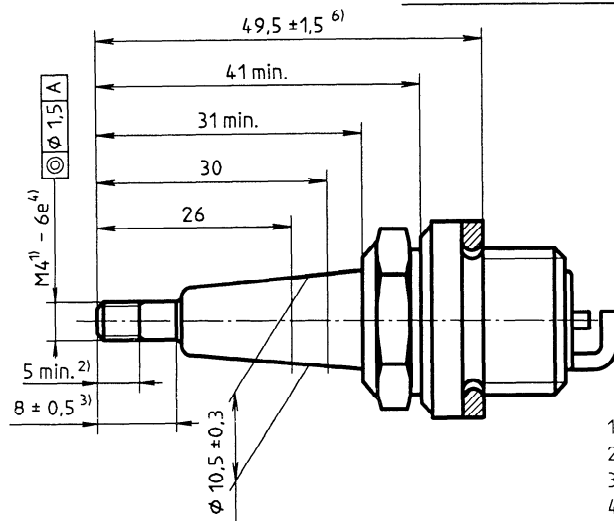

b) With threaded terminal⁵⁾

- 1) 0,7 mm pitch complying with ISO 68 and ISO 261.
- 2) Length of usable thread.
- 3) Cylindrical part.
- 4) Depending upon manufacturing processes, class 7e is acceptable on the finished product.
- 5) Other dimensions: see figure 1 a).
- 6) See 3.3.

Figure 1 – M14 × 1,25 spark-plugs with flat seating and 16 mm hexagon

iTeh STANDARD PREVIEW
(standards.iteh.ai)

This page intentionally left blank

[ISO 8470:1990/Amd 1:1993](#)

<https://standards.iteh.ai/catalog/standards/sist/dea68334-ca69-45fa-b7d4-6ab554361f4e/iso-8470-1990-amd-1-1993>

iTeh STANDARD PREVIEW
(standards.iteh.ai)

This page intentionally left blank

[ISO 8470:1990/Amd 1:1993](#)

<https://standards.iteh.ai/catalog/standards/sist/dea68334-ca69-45fa-b7d4-6ab554361f4e/iso-8470-1990-amd-1-1993>

iTeh STANDARD PREVIEW
(standards.iteh.ai)

This page intentionally left blank

[ISO 8470:1990/Amd 1:1993](#)

<https://standards.iteh.ai/catalog/standards/sist/dea68334-ca69-45fa-b7d4-6ab554361f4e/iso-8470-1990-amd-1-1993>

iTeh STANDARD PREVIEW
(standards.iteh.ai)

ISO 8470:1990/Amd 1:1993

<https://standards.iteh.ai/catalog/standards/sist/dea68334-ca69-45fa-b7d4-6ab554361f4e/iso-8470-1990-amd-1-1993>

UDC 621.43.045 : 621.11

Descriptors: road vehicles, internal combustion engines, controlled ignition engines, ignition systems, spark plugs, dimensions.

Price based on 2 pages
