

---

# International Standard



# 8479

---

INTERNATIONAL ORGANIZATION FOR STANDARDIZATION • МЕЖДУНАРОДНАЯ ОРГАНИЗАЦИЯ ПО СТАНДАРТИЗАЦИИ • ORGANISATION INTERNATIONALE DE NORMALISATION

---

## Aerospace — “Q” clamps (centre-mounted clamps) for fluid systems — Dimensions

*Aéronautique et espace — Colliers à serrage central pour systèmes de fluides — Dimensions*

First edition — 1986-12-01

**iTeh STANDARD PREVIEW**  
**(standards.iteh.ai)**

ISO 8479:1986

<https://standards.iteh.ai/catalog/standards/sist/309b1e84-41c0-4993-8af3-3b51d57eae19/iso-8479-1986>

---

UDC 621.643.45 : 629.7

Ref. No. ISO 8479-1986 (E)

Descriptors: aircraft, aircraft equipment, fluids, fluid pipelines, pipe clips, pipe supports, dimensions.

## Foreword

ISO (the International Organization for Standardization) is a worldwide federation of national standards bodies (ISO member bodies). The work of preparing International Standards is normally carried out through ISO technical committees. Each member body interested in a subject for which a technical committee has been established has the right to be represented on that committee. International organizations, governmental and non-governmental, in liaison with ISO, also take part in the work.

Draft International Standards adopted by the technical committees are circulated to the member bodies for approval before their acceptance as International Standards by the ISO Council. They are approved in accordance with ISO procedures requiring at least 75 % approval by the member bodies voting.

International Standard ISO 8479 was prepared by Technical Committee ISO/TC 20, *Aircraft and space vehicles*.

Users should note that all International Standards undergo revision from time to time and that any reference made herein to any other International Standard implies its latest edition, unless otherwise stated.

iTeh STANDARD PREVIEW  
(standards.iteh.ai)

<http://standards.iteh.ai/catalog/standards/sic/59961e84-41c0-4993-8af3-3b51d57eae19/iso-8479-1986>

# Aerospace — “Q” clamps (centre-mounted clamps) for fluid systems — Dimensions

## iTeh STANDARD PREVIEW (standards.iteh.ai)

### 1 Scope

This International Standard specifies maximum and minimum dimensions for “Q” clamps (centre-mounted clamps) installed by means of a bolt with a nominal diameter of 5 mm.

The specified dimensions define a dimensional envelope. This International Standard shall not be considered as an interchangeability standard. The tolerances for each type of clamp are to be defined in the parts standards drawings.

### 2 Field of application

These clamps are intended for the installation, support and guiding of rigid tubing or hose assemblies used in aerospace equipment.

NOTE — “Q” clamps of sizes larger than DN 50 are not suitable for supporting tubing or hose assemblies; they may be used for other equipment, e.g. electrical cables or looms.

### 3 Reference

ISO 6771, *Aerospace construction — Fluid systems and components — Pressure and temperature classifications.*

### 4 Field of use

“Q” clamps (centre-mounted clamps) are classified into six types according to the temperature range in which they are intended to be used (see table 1).

Table 1

Temperatures in degrees Celsius

Clamp type	Temperature range <sup>1)</sup>	
	min.	max.
1	– 55	+ 70
2	– 55	+ 135
3	– 55	+ 200
4	– 55	+ 320
5	– 55	+ 400
6	– 55	+ 650

1) See ISO 6771.

### 5 Description

The “Q” clamp (centre-mounted clamp) is a “single-block” or a “multi-component”-type clamp. The “multi-component”-type clamp is provided as a metallic support with a plastomer or elastomer cushion or sheathing.

### 6 Dimensions

The “Q” clamp (centre-mounted clamp) shall be in accordance with the figure and table 2.

The shape of the clamp illustrated in the figure does not purport to be the exact shape of the manufactured clamp. Table 2 only specifies those dimensions required to define the maximum envelope and the proper location of the tube relative to the mounting plane and fastening point.

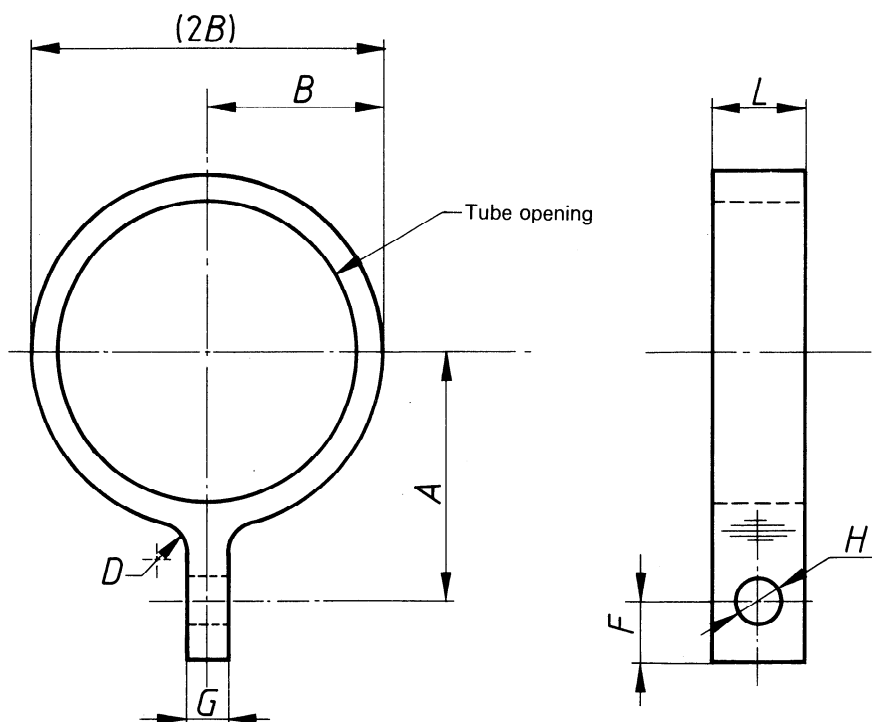

Figure — Maximum envelope dimensions for "Q" clamps (centre-mounted clamps)

(standards.iteh.ai)

Table 2<sup>1)</sup>

ISO 8479-1986

Dimensions in millimetres

Nominal diameter of tube DN <sup>2)</sup>	A		B <sup>3)</sup>		D	F	G	H		L <sup>3)</sup>
	min.	max.	min.	max.	max.	max.	max.	min.	max.	max.
03,2	10,6	12,3	2	6,4	2,3	6,6	1,8	5,2	5,8	19
04	11	12,7	2,4	6,8	2,3	6,6	1,8	5,2	5,8	19
05	11,5	13,2	2,9	7,3	2,3	6,6	1,8	5,2	5,8	19
06	12	13,7	3,4	7,8	2,3	6,6	1,8	5,2	5,8	19
08	13	14,7	4,4	8,8	2,3	6,6	1,8	5,2	5,8	19
10	14	15,7	5,4	9,8	2,3	6,6	1,8	5,2	5,8	19
12	15	16,7	6,4	10,8	2,3	6,6	1,8	5,2	5,8	19
14	17,5	19,1	7,4	11,8	2,3	6,6	2,6	5,2	5,8	19
16	18,5	20,1	8,4	12,8	2,3	6,6	2,6	5,2	5,8	19
18	19,5	21,1	9,4	13,8	2,3	6,6	2,6	5,2	5,8	19
20	20,5	22,1	10,4	14,8	2,3	6,6	2,6	5,2	5,8	19
22	21,5	23,1	11,4	15,8	2,3	6,6	2,6	5,2	5,8	19
25	23	24,6	12,9	17,9	3,2	6,6	2,6	5,2	5,8	21
28	24,5	26,8	14,4	19,4	3,2	6,6	3,3	5,2	5,8	21
32	26,5	28,8	16,5	21,4	3,2	6,6	3,3	5,2	5,8	21
36	28,5	30,8	18,5	23,4	3,2	6,6	3,3	5,2	5,8	21
40	30,5	32,8	20,5	25,4	3,2	6,6	3,3	5,2	5,8	21
45	34,5	34,9	23	27,9	3,2	6,6	3,3	5,2	5,8	21
50	37	37,4	25,5	30,4	3,2	6,6	3,3	5,2	5,8	21
56	40,7	41,1	28,5	33,8	3,7	6,6	3,3	5,2	5,8	24
63	44,2	44,6	32	37,3	3,7	6,6	3,3	5,2	5,8	24
70	47,7	48,1	35,5	40,8	3,7	6,6	3,3	5,2	5,8	24
80	52,7	53,1	40,5	45,8	3,7	6,6	3,3	5,2	5,8	24
90	57,7	58,1	45,5	50,8	3,7	6,6	3,3	5,2	5,8	24
100	62,7	63,1	50,5	55,8	3,7	6,6	3,3	5,2	5,8	24

1) All dimensions in this table apply with the tube assembled in the tightened clamp.

2) Diameters DN 14, 18, 22, 28, 36, 45, 56, 70 and 90 are non-preferred sizes for tubing in fluid systems.

3) This dimension is an overall dimension which includes metal width and cushion or sheathing.