

INTERNATIONAL STANDARD

ISO
8482

First edition
1987-11-15



INTERNATIONAL ORGANIZATION FOR STANDARDIZATION
ORGANISATION INTERNATIONALE DE NORMALISATION
МЕЖДУНАРОДНАЯ ОРГАНИЗАЦИЯ ПО СТАНДАРТИЗАЦИИ

Information processing systems — Data communication — Twisted pair multipoint interconnections

iTeh STANDARD PREVIEW

*Systèmes de traitement de l'information — Communication de données — Interconnexions
multipoints par paire torsadée*

(standards.iteh.ai)

ISO 8482:1987

<https://standards.iteh.ai/catalog/standards/sist/cc124279-7c28-4d9b-ba16-d5f7497d1a22/iso-8482-1987>

Reference number
ISO 8482:1987 (E)

Foreword

ISO (the International Organization for Standardization) is a worldwide federation of national standards bodies (ISO member bodies). The work of preparing International Standards is normally carried out through ISO technical committees. Each member body interested in a subject for which a technical committee has been established has the right to be represented on that committee. International organizations, governmental and non-governmental, in liaison with ISO, also take part in the work.

Draft International Standards adopted by the technical committees are circulated to the member bodies for approval before their acceptance as International Standards by the ISO Council. They are approved in accordance with ISO procedures requiring at least 75 % approval by the member bodies voting.

International Standard ISO 8482 was prepared by Technical Committee ISO/TC 97, *Information processing systems*.

Users should note that all International Standards undergo revision from time to time and that any reference made herein to any other International Standard implies its latest edition, unless otherwise stated.

ITeH STANDARD PREVIEW
(standards.iteh.ai)

ISO 8482:1987
standards.iteh.ai/catalog/standards/sist/cc124279-7c28-4d9b-ba16-d5f7497d1a22/iso-8482-1987

Information processing systems — Data communication — Twisted pair multipoint interconnections

1 Scope and field of application

1.1 This International Standard specifies the physical medium characteristics for

- twisted pair multipoint interconnections in either 2-wire or 4-wire network topology in order to provide for half duplex or duplex data transmission capability, respectively;
- a binary and bidirectional signal transfer of the inter-connected endpoint systems;
- the electrical and mechanical design of the endpoint system branch cables and the common trunk cable, which may be up to 500 m in length;
- the component measurements of the integrated circuit type generators and receivers within the endpoint systems;
- the applicable data signalling rate up to 1 Mbit/s.

1.2 The defined electrical component characteristics and measurements are in close conformance with the twisted pair point-to-point characteristics given in CCITT Recommendation V.11.

1.3 This International Standard does not describe a complete physical interface and has no functional interface characteristics, such as

- number of interchange data and control circuits;
- type, size and pin allocation of the endpoint system branch cable connectors;
- data and control signal encoding;
- time relations between signals on the interchange circuits;
- mode of synchronous or asynchronous transmission;
- signal quality for transmission and reception.

1.4 This International Standard does not specify special environmental conditions, such as galvanic isolation, electromagnetic interference (EMI), radio frequency interference (RFI), and human safety. This may form the subject of a future addendum.

1.5 This International Standard is primarily a component specification. It is not sufficiently specified for satisfactory interoperations in all possible configurations. It is the responsibility of implementors to ensure that their intended configuration will allow satisfactory interoperation.

1.6 This International Standard may be combined with any appropriate set of functional and additional environmental characteristics so as to meet the practical data transmission requirements in the field of local or wide area networks.

2 Reference

CCITT Recommendation V.11, *Electrical characteristics for balanced double-current interchange circuits for general use with integrated circuit equipment in the field of data communications.*

3 Definitions

The definitions of the specified electrical characteristics are given in annex B.

4 Symbolic representation of an interchange circuit (see figure 1)

The symbolic representation of an interchange circuit is in principle as given in CCITT Recommendation V.11.

However, the generator of this International Standard includes an additional control to place the device into the active state or the inactive, high impedance zero voltage state. This addition is shown in the symbolic representation reproduced in figure 1.

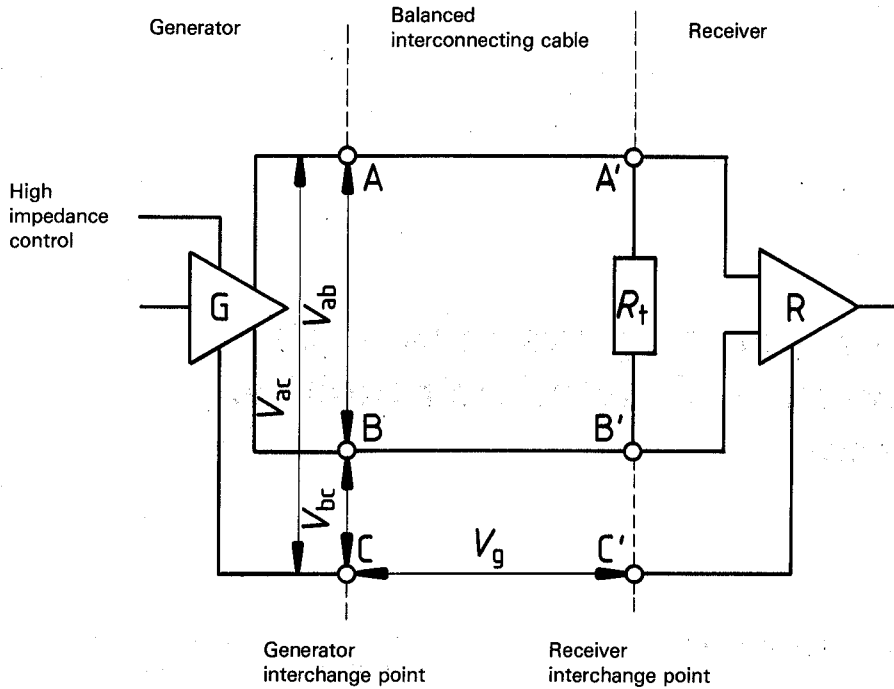

- V_{ab} = Generator output voltage between points A and B
- V_{ac} = Generator voltage between points A and C
- V_{bc} = Generator voltage between points B and C
- V_g = Ground potential difference
- R_t = Cable termination resistor
- A, B and A', B' = Interchange points
- C, C' = Zero volt reference interchange points (Signal ground)

ITeH STANDARD PREVIEW
(standards.iteh.ai)

ISO 8482:1987
<https://standards.iteh.ai/catalog/standards/sist/cc124279-7c28-4d9b-ba16-d5f7497d1a22/iso-8482-1987>

NOTES

- 1 Two interchange points are shown. The output characteristics of the generator, excluding any interconnecting cable, are defined at the "generator interchange point". The electrical characteristics to which the receiver must respond are defined without the cable termination resistor at the "receiver interchange point".
- 2 Points C and C' may be interconnected and further connected to protective ground if required by national regulations.

Figure 1 — Symbolic representation of interchange circuit

5 Interconnection configurations (see figures 2 and 3)

In general, the interconnection configuration consist of one balanced trunk cable, which may be up to 500 m in length, and several balanced branch cables, each connecting an individual endpoint system to the common trunk cable. The branch cable connection points may be spaced as appropriate. A branch cable may be up to 5 m in length.

The balanced trunk cable shall be terminated by a termination resistor at each end. At the individual endpoint system connecting points, a branch/trunk cable connector shall be used. This facilitates the generator/receiver load measurements defined in 6.1.2. The female connector(s) at each end of the trunk cable shall accommodate the termination resistor(s).

All balanced cables may be shielded if required by local regulations. It may also be necessary to extend shielding across the branch/trunk cable connectors.

Depending on the type of multipoint operation, either a two wire or a four wire interconnection configuration may be used. Figure 2 shows a two wire multipoint configuration for half duplex data transmission, while figure 3 shows a four wire multipoint configuration for either half duplex or duplex data transmission.

6 Load on the multipoint medium

Each endpoint system represents a load to the multipoint medium. The load consists of a passive generator and/or a receiver with associated internal wiring and a balanced branch

cable as shown in figures 2 and 3. In accordance with the multi-point half duplex data transmission principle, only one generator is in the active state at a given time.

Successful operation requires specification of the load in terms of d.c. and a.c. loading. For d.c. loading, the component

specifications in clauses 8 and 9 are selected such that an active generator can drive the interconnecting trunk cable, terminated at each end with not less than 120Ω , and 32 so-called Unit Loads (ULs), representing the total load of all endpoint systems. The value of 1,0 UL is defined in 6.1.1.

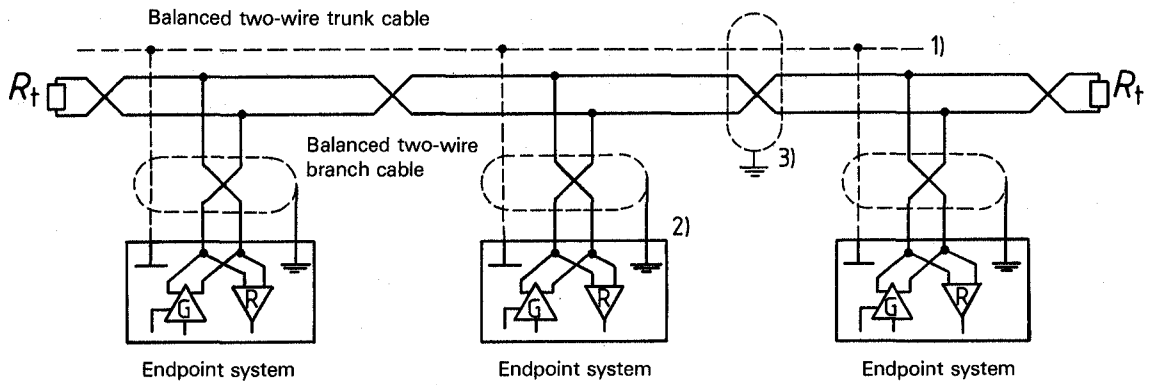
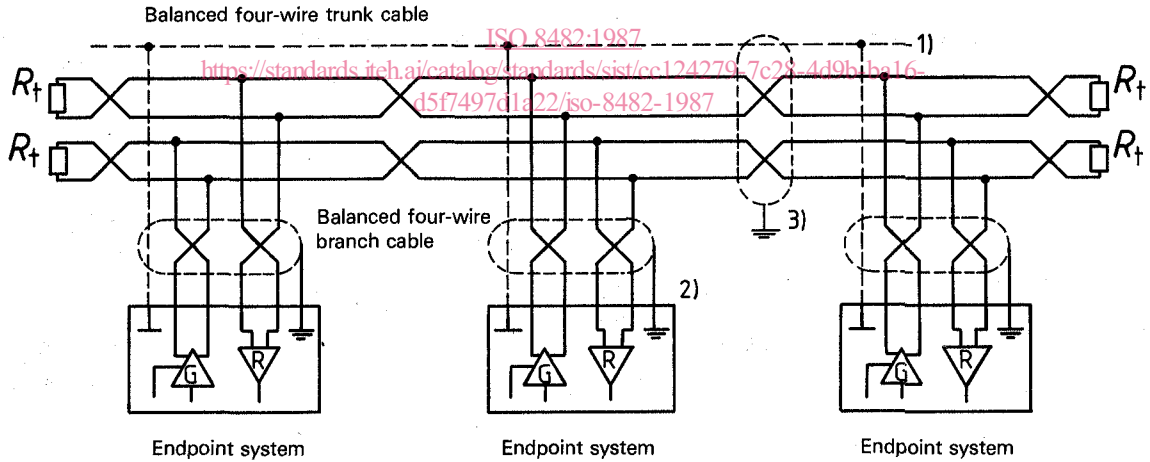

Figure 2 – Two-wire multipoint configuration

iTeh STANDARD PREVIEW
(standards.iteh.ai)



Legend: \perp Signal ground \perp Protective ground

NOTES

- 1) Interconnection of the endpoint system signal ground is optional and depends on local regulations.
- 2) Branch cable shield is optional and, when provided, it connects to the endpoint system protective ground, which may be further connected to the signal ground.
- 3) Trunk cable shield is optional and, when provided, it connects to a protective ground at one place. Interconnection of shield to branch cable shields may be necessary.

Figure 3 – Four-wire multipoint configuration

6.1 Specification of d.c. loading

The d.c. loading specification limits the current of an active generator to a practical value. For this reason, a hypothetical Unit Load (UL) is defined for a current/voltage measurement.

6.1.1 UL definition (see figure 4)

The value of 1,0 UL is defined by a current ranging between -0,8 mA and +1,0 mA when varying the voltage between -7 V and +12 V. The correspondent current/voltage diagram is shown in figure 4.

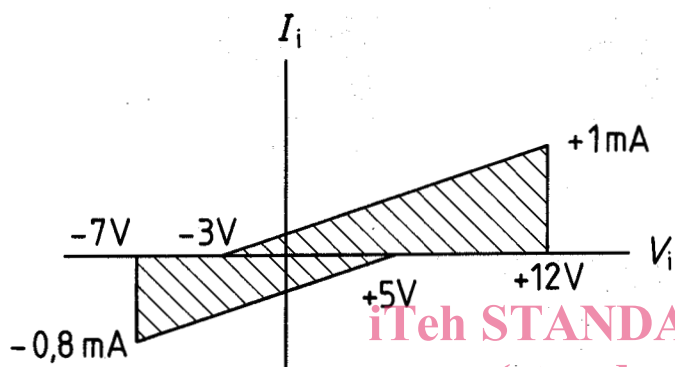

The voltage range takes into account the output and offset voltage of the generator, the common mode and internal voltage of the receiver and the power supply voltage.

6.1.2 UL determination of the endpoint systems (see figures 5 and 6)

When measuring the current/voltage characteristics at the male pin branch/trunk cable connector of one endpoint system, the measured generator shall be in the inactive state. The measurement configuration is shown in figure 5.

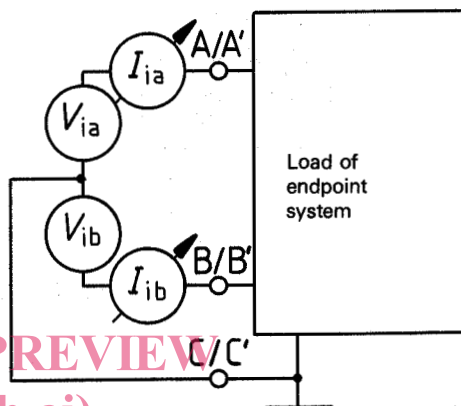

Figure 4 – Current limit of 1,0 UL

ISO 8482:1987 Figure 5 – Input current/voltage measurement

<https://standards.iteh.ai/catalog/standards/sist/cc124279-7c28-4d9b-ba16-d5f7497d1a22/iso-8482-1987>

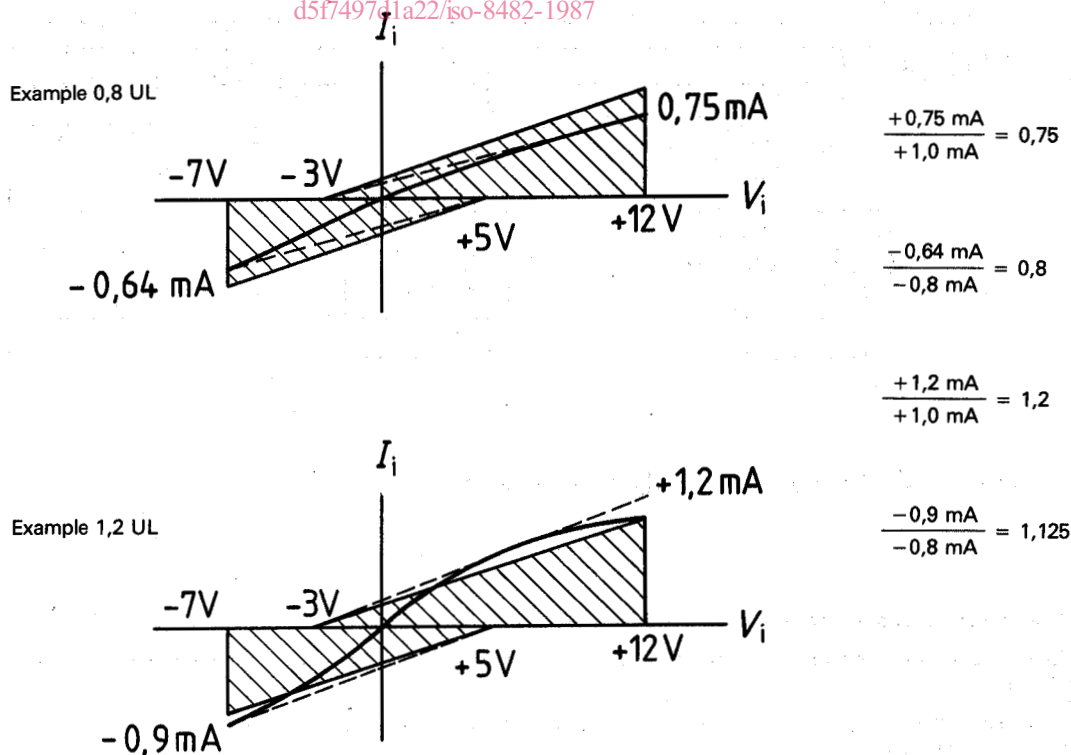

Figure 6 – UL value determination

The current/voltage measurement corresponds to that of the V.11 receiver input in CCITT Recommendation V.11, i.e. with the voltage V_{ia} (or V_{ib}) ranging between -7 V and $+12\text{ V}$, while V_{ib} (or V_{ia}) is held at zero volts, the resulting input current I_{ia} (or I_{ib}) should remain within the shaded range shown in figure 4.

These measurements apply with the power supply of the generator and/or receiver in both the power-on and power-off conditions.

To determine UL from the measurements, the slope of the bounds of the current limit of one UL, see figure 4, shall be modified to the minimum slope required to fully contain the current/voltage characteristics, while the -3 V and $+5\text{ V}$ intercept points are maintained. The actual value of UL is then equal to the larger of the two ratios of the actual current to the one UL current at the -7 V and $+12\text{ V}$ points (see the two examples of UL value determination in figure 6).

The slopes of the currents should be positive to lower the possibility of oscillations from negative resistance.

When adding all measured UL values, the sum shall not exceed 32,0.

6.2 Specification of a.c. loading

The a.c. loading on the interconnecting multipoint medium caused by the endpoint systems affects the transmission characteristics. This depends on application parameters, such as type of balanced cable and data signalling rate. For this reason, the following measurements are for guidance only and may have to be revised as necessary (see clause A.2 of annex A).

6.2.1 Reflexion attenuation

The reflexion attenuation of an endpoint system should not be less than 20 dB. The measurement is made on the male pin branch/trunk cable connector using a parallel test resistor of $120\ \Omega$. During measurement, the generator, if any, is in the inactive state.

6.2.2 Receiving distortion

The receiving signal distortion measured on the female pin branch/trunk cable connector, terminated with a $120\ \Omega$ resistor, for mark/space reversals at the applied data signalling rate shall not exceed 25 %.

NOTE — In the case of the twisted pair transmission medium, it is assumed that the pattern dependent distortion is not very far outside the range of the mark/space reversals measurement.

7 Polarities and significant levels

The generator polarities and receiver significant levels correspond to those in CCITT Recommendation V.11. Table 1 is reproduced from CCITT Recommendation V.11.

Table 1 — Receiver differential significant levels

	$V_{A'} - V_{B'} \leq -0,3\text{ V}$	$V_{A'} - V_{B'} \geq +0,3\text{ V}$
Data circuits	MARK, 1	SPACE, 0
Control and timing circuits	OFF	ON

8 Generator characteristics

The generator component is measured in the active, low impedance state by the following tests using the measurement configurations shown in figures 7 to 10. The component may be operated from a single-rail positive power supply.

The tests are made for either binary state, whereby for the magnitude of the voltage specifications both symbols $|V|$ and $|\bar{V}|$ are used, respectively.

8.1 Open circuit voltage, V_o

The voltage, when measured in accordance with figure 7, shall be, between the

- output terminals A,B: $1,5\text{ V} < |V_o| \text{ or } |\bar{V}_o| < 6,0\text{ V}$
- terminals A,C and B,C: $|V_{oa}| \text{ or } |V_{ob}| \text{ or } |\bar{V}_{oa}| \text{ or } |\bar{V}_{ob}| < 6,0\text{ V}$

8.2 Offset voltage, V_{os}

The voltage, when measured in accordance with figure 8, shall be, between the

- load centre and terminal C: $0\text{ V} < V_{os} \text{ or } \bar{V}_{os} < 3,0\text{ V}$
- binary states, the difference: $|V_{os} - \bar{V}_{os}| < 0,2\text{ V}$

8.3 Terminated output voltage, V_t

The voltage, when measured in accordance with figure 9 by varying the testing voltage V in the range from -7 V to $+12\text{ V}$ shall be, between the

- output terminals A,B: $1,5\text{ V} < |V_t| \text{ or } |\bar{V}_t| < 5,0\text{ V}$
- binary states, the difference: $|V_t| - |\bar{V}_t| < 0,2\text{ V}$

8.4 Rise time, t_r , and imbalance voltage, V_e

When testing the mark/space reversals voltage V_{ss} in accordance with figure 10

- the rise and fall time between 0,1 and 0,9 of V_{ss} on the output terminals A,B shall be

$$t_r \leq 0,3 t_b$$

where

t_b = time of UI (unit interval); and

$$V_{ss} = |V_t - \bar{V}_t|$$

— the resultant voltage due to imbalance between load centre and terminal C shall be

$$V_e < 0,4 \text{ V peak-to-peak.}$$

9 Receiver characteristics

The receiver component is measured in accordance with the measurement configurations shown in figures 11 and 12.

A component meeting these requirements results in a differential receiver having a high input impedance, a small input threshold transition region between $-0,3 \text{ V}$ and $+0,3 \text{ V}$ differential, and allowance for an internal bias voltage not exceeding 3 V in magnitude.

9.1 Input sensitivity (see figure 11)

The permitted range of input voltages $V_{A'}$ and $V_{B'}$ appearing at the receiver input terminals A' and B' measured with respect to receiver terminal C' shall be between -7 V and $+12 \text{ V}$. For any combination of receiver input voltages within this permitted range, the receiver shall assume the intended binary state with an applied differential input voltage V_i of $\pm 0,3 \text{ V}$ or more. In addition, the receiver shall not sustain any damage when connecting its input terminals A' or B' and C' to a testing voltage variable from -10 V to $+15 \text{ V}$.

9.2 Input balance (see figure 12)

The balance of the receiver input voltage/current characteristics and internal bias voltages shall be such that the receiver will remain in the intended binary state when a differential voltage V_{R3} of $\pm 0,6 \text{ V}$ is applied through matched resistors equal to $1\,500 \, \Omega$ to each input terminal, as shown in figure 12, with the input voltages V_{R1} and V_{R2} ranging between -7 V and $+12 \text{ V}$. When the polarity of V_{R3} reverses, the opposite binary state shall be maintained under the same conditions.

10 Fault condition tests

In order to ensure no damage occurs due to a single fault condition the components shall be tested in accordance with the measurement configurations shown in figures 13 to 15.

10.1 Generator short circuit (see figure 13)

A generator shall not sustain any damage as a result of short-circuiting its output terminals A and B to each other.

10.2 Generator contention (see figure 14)

A generator shall not sustain any damage as a result of connecting its output terminals A or B and C to a testing voltage, variable from -10 V to $+15 \text{ V}$, under any output condition, binary 0 or 1, or passive.

10.3 Generator current limitation (see figure 14)

The peak current in any lead to the generator shall not exceed 250 mA when testing in accordance with figure 14 by varying the testing voltage V in the range from -7 V to $+12 \text{ V}$ with a slew rate of the voltage equal to or less than $1,2 \text{ V per } \mu\text{s}$.

This criterion should not be interpreted as a requirement that a generator be capable of sourcing 250 mA . Rather, the sinking generator shall not permit a composite current in excess of 250 mA , if multiple (sourcing) generators are providing that current. (See annex A clause A.4 for additional information on generator contention.)

10.4 Transient over-voltage (see figure 15)

The measurement in accordance with figure 15 applies to both generators and receivers. Protection shall be provided from transients that may occur on an interchange circuit when the high current due to a single contending pair of generators is interrupted. (See annex A clause A.4 for additional information.)

A passive generator or a receiver shall be able to withstand without failure applied pulses of $15 \, \mu\text{s}$ duration at 1 % duty cycle from a 25 V source having $100 \, \Omega$ source impedance. Both positive and negative pulses shall be applied between terminals A and C and between terminals B and C on passive generators and between terminals A' and C' and between terminals B' and C' on receivers. If the component should experience breakdown during the applied pulse, it shall return to the operational state within 200 ns after termination of the applied pulse.

11 Environmental constraints

In order to operate a balanced interchange circuit at data signalling rates up to 1 Mbit/s , the following conditions apply:

The total common-mode voltage at any point of the interchange circuit shall be within -7 V to $+7 \text{ V}$. However, this range is extended in the generator contention case to $+12 \text{ V}$ (see clause A.4 of annex A.)

The common mode voltage at the receiver is the worst case combination of

- generator-receiver ground potential difference (V_g , see figure 1);
- longitudinally induced random noise voltage measured between the receiver terminals A' or B' and C' with the generator ends of the cable A, B, and C joined together;
- generator offset voltage V_{os} .

12 Component compatibility

In certain instances, it may be possible to produce generators and receivers that meet the requirements of both CCITT Recommendation V.11 and this International Standard.

Table 2 – Compatibility with CCITT Recommendation V.11

Characteristics	ISO 8482	CCITT Recommendation V.11
Generator and receiver		
Power supply	positive	positive and/or negative
Common mode	-7 V to +7 V	-7 V to +7 V
No damage	-10 V to +15 V	-12 V to +12 V
Transient over-voltage	-25 V and +25 V	-
Generator		
Open circuit	< 6,0 V	< 6,0 V
Output terminated	1,5 V to 5,0 V/54 Ω	2,0 V to 6,0 V/100 Ω
Offset	< 3,0 V	< 3,0 V
Mark/Space difference	< 0,2 V	< 0,4 V
Rise/Fall time	< 0,3 UI	< 0,1 UI
Imbalance	< 0,4 V p/p	< 0,4 V p/p
Short circuit	-	< 150 mA
Current limitation	< 250 mA	-
Receiver		
Sensitivity min.	± 300 mV	± 300 mV
Sensitivity range	-7 V to +12 V	-10 V to +10 V
Imbalance	± 600 mV	± 720 mV
Internal bias	< 3,0 V	< 3,0 V
Failure detection	-	3 types

iTeh STANDARD PREVIEW
(standards.iteh.ai)

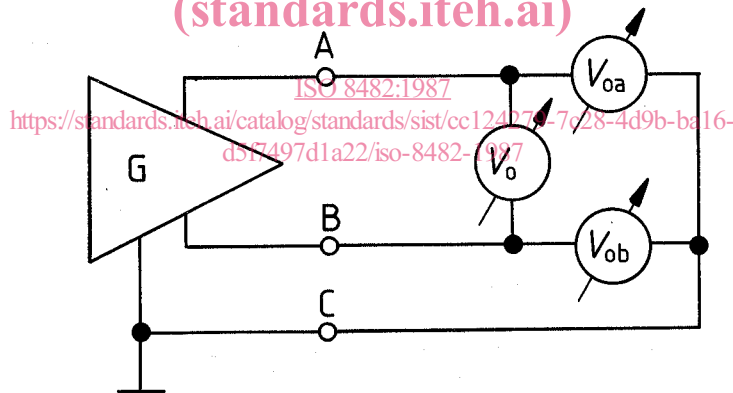

Figure 7 – Open circuit voltage measurement

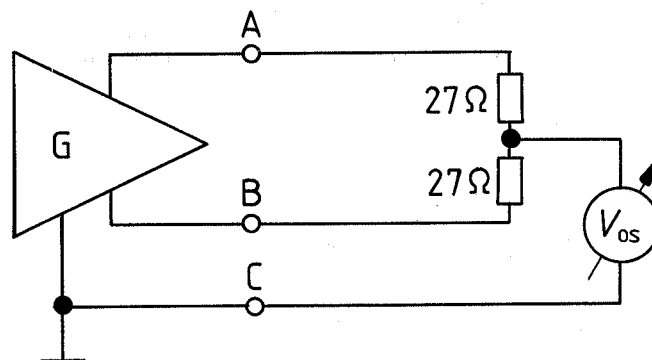

Figure 8 – Offset voltage measurement

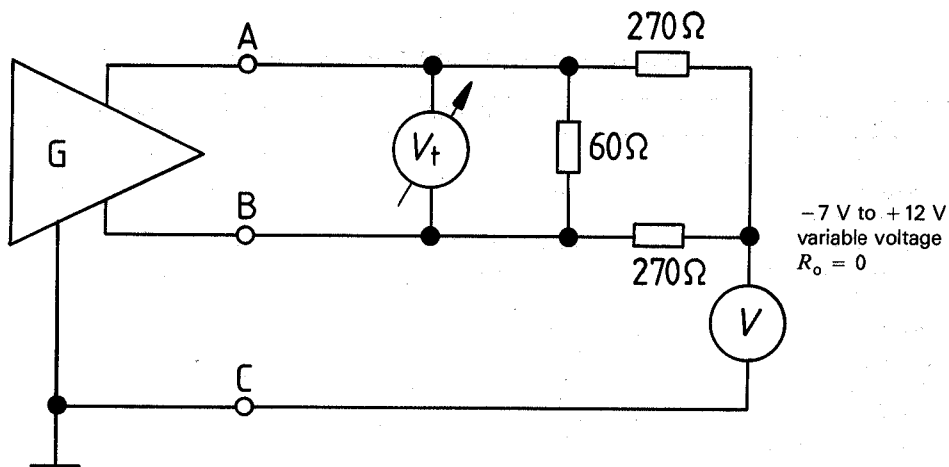
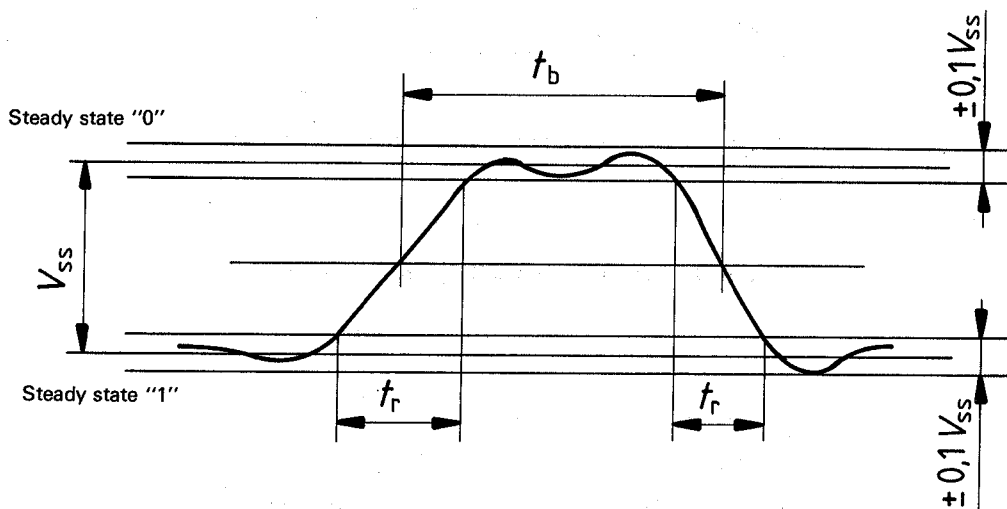
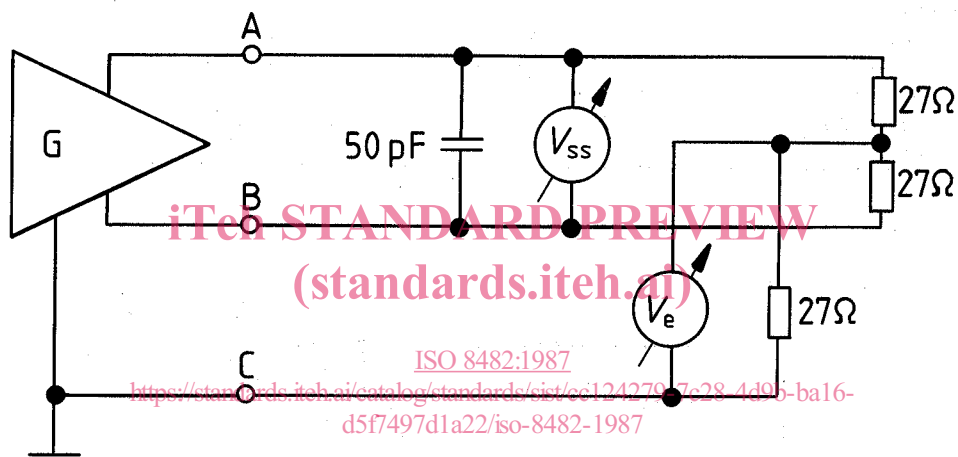
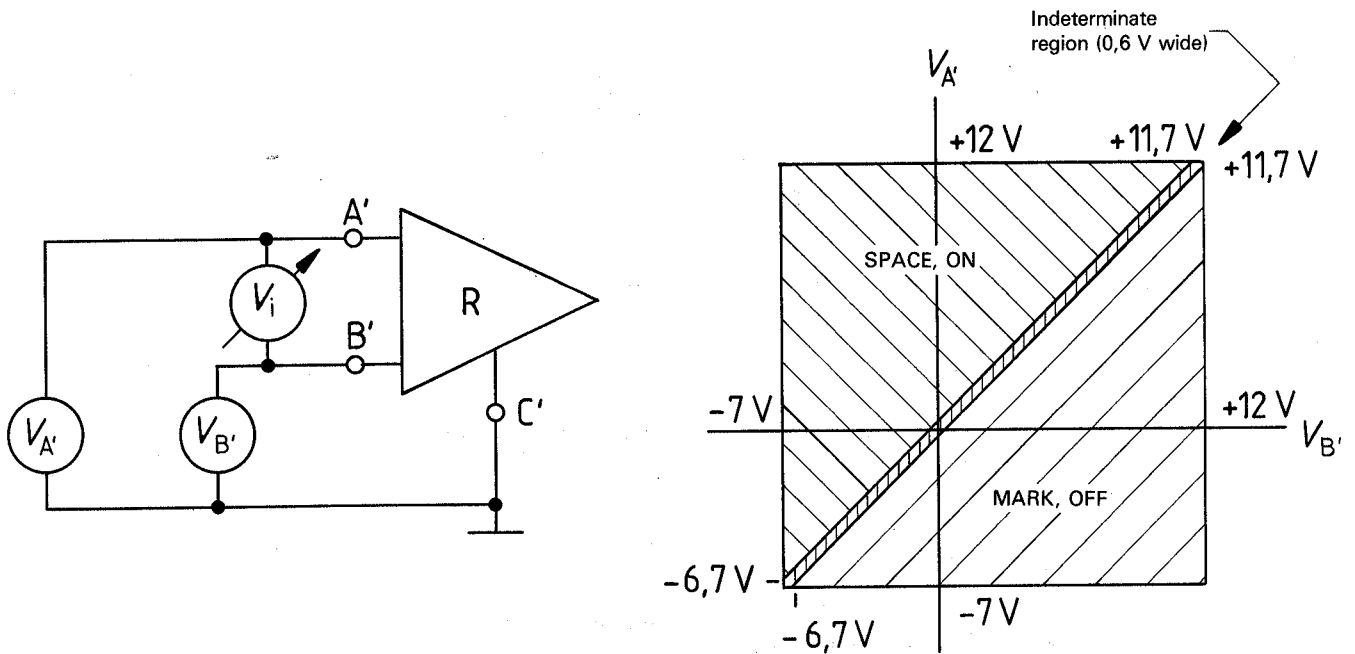

Figure 9 — Terminated output voltage measurement



- t_r = Rise time
- t_b = Time duration of the unit interval at the applicable data signalling rate
- $t_r < 0,3 t_b$
- V_{ss} = Difference in steady state voltages
- $V_{ss} = |V_t - \bar{V}_t|$

Figure 10 — Rise time and imbalance measurement



iTeh STANDARD PREVIEW
 Figure 11 – Input voltage range
 (standards.iteh.ai)

ISO 8482:1987

<https://standards.iteh.ai/catalog/standards/sist/cc124279-7c28-4d9b-ba16-d5f7497d1a22/iso-8482-1987>

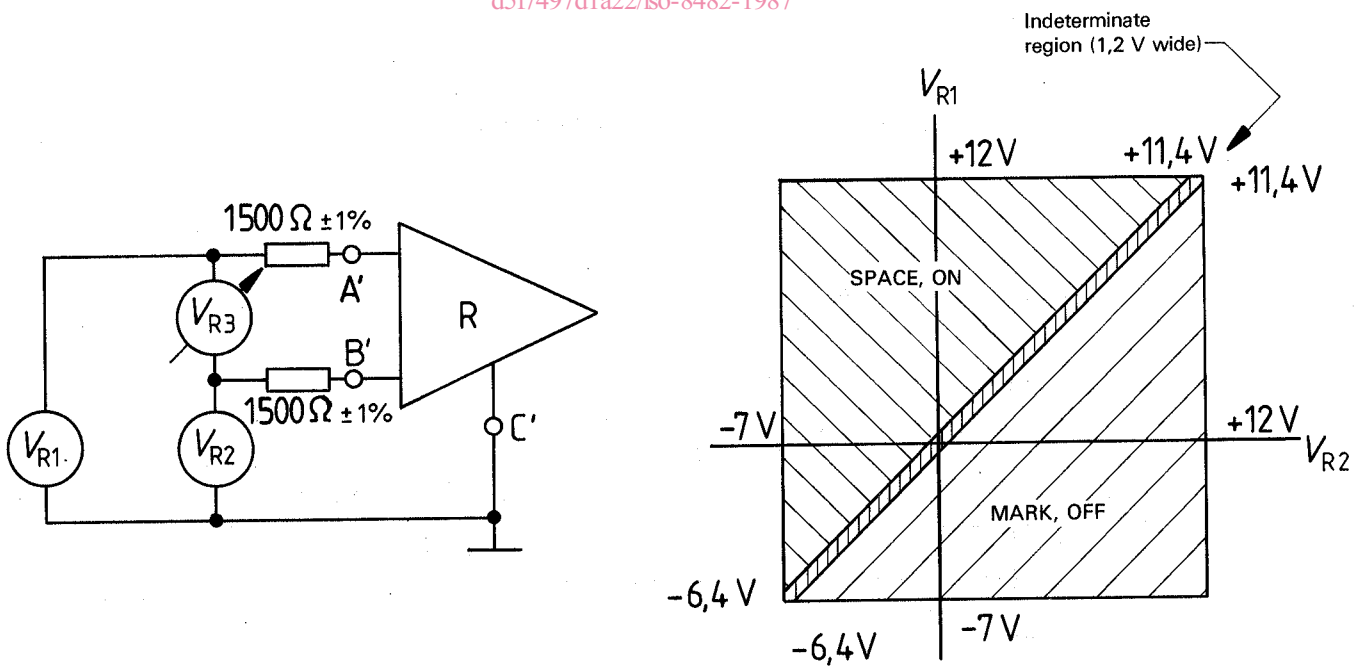

Figure 12 – Input balance measurement