



Standard Test Method for Length Change of Hardened Hydraulic-Cement Mortar and Concrete¹

This standard is issued under the fixed designation C 157/C 157M; the number immediately following the designation indicates the year of original adoption or, in the case of revision, the year of last revision. A number in parentheses indicates the year of last reapproval. A superscript epsilon (ϵ) indicates an editorial change since the last revision or reapproval.

This standard has been approved for use by agencies of the Department of Defense.

1. Scope

1.1 This test method covers the determination of the length changes that are produced by causes other than externally applied forces and temperature changes in hardened hydraulic-cement mortar and concrete specimens made in the laboratory and exposed in the laboratory to controlled conditions of temperature and moisture.

1.2 The values stated in either inch-pound or SI units are to be regarded separately as standard. An exception is with regard to sieve sizes and nominal size of aggregate, in which the SI values are the standard as stated in Specification E 11. Within the text, the SI units are shown in brackets. The values stated in each system may not be exact equivalents; therefore, each system must be used independently of the other, without combining values in any way.

1.3 *This standard does not purport to address all of the safety concerns, if any, associated with its use. It is the responsibility of the user of this standard to establish appropriate safety and health practices and determine the applicability of regulatory limitations prior to use.*

2. Referenced Documents

2.1 ASTM Standards:

- C 109/C 109M Test Method for Compressive Strength of Hydraulic Cement Mortars (Using 2-in. or 50-mm Cube Specimens)²
- C 125 Terminology Relating to Concrete and Concrete Aggregates³
- C 143/C 143M Test Method for Slump of Hydraulic Cement Concrete³
- C 172 Practice for Sampling Freshly Mixed Concrete³
- C 192/C 192M Practice for Making and Curing Concrete Test Specimens in the Laboratory³
- C 305 Practice for Mechanical Mixing of Hydraulic Cement Pastes and Mortars of Plastic Consistency²
- C 490 Practice for Use of Apparatus for the Determination

¹ This test method is under the jurisdiction of ASTM Committee C-9 on Concrete and Concrete Aggregates and is the direct responsibility of Subcommittee C09.68 on Methods of Testing for Volume Changes of Concrete and Concrete Aggregates.

Current edition approved July 10, 1999. Published July 1999. Originally published as C 157 – 40 T. Last previous edition C 157 – 93.

² *Annual Book of ASTM Standards*, Vol 04.01.

³ *Annual Book of ASTM Standards*, Vol 04.02.

of Length Change of Hardened Cement Paste, Mortar, and Concrete²

C 511 Specification for Moist Cabinets, Moist Rooms, and Water Storage Tanks Used in the Testing of Hydraulic Cements and Concretes²

C 596 Test Method for Drying Shrinkage of Mortar Containing Portland Cement²

E 11 Specification for Wire and Cloth Sieves for Testing Purposes⁴

E 337 Test Method for Measuring Humidity with a Psychrometer (the Measurement of Wet-Bulb and Dry-Bulb Temperatures)⁵

3. Terminology

3.1 *Definitions*—The terms used in this test method are defined in Terminology C 125.

3.2 *Definitions of Terms Specific to This Standard:*

3.2.1 *length change, n*—an increase or decrease in the length of a test specimen that has been caused to change by any factor other than externally applied forces and temperature changes.

4. Significance and Use

4.1 Measurement of length change permits assessment of the potential for volumetric expansion or contraction of mortar or concrete due to various causes other than applied force or temperature change. This test method is particularly useful for comparative evaluation of this potential in different hydraulic-cement mortar or concrete mixtures.

4.2 This test method may provide useful information for experimental purposes or for products that require testing under nonstandard mixing, placing, handling, or curing conditions, such as high product workability or different demolding times. Standard conditions are described in 5.4.1.

4.3 If conditions for mixing, curing, sampling, and storage other than specified in this test method are required, they shall be reported but are not to be considered as standard conditions of this test method. Nonstandard conditions shall be reported clearly and prominently with comparator values, and the reasons for departure from standard conditions also shall be

⁴ *Annual Book of ASTM Standards*, Vol 14.02.

⁵ *Annual Book of ASTM Standards*, Vol 11.03.

ASTM C 157/C 157M

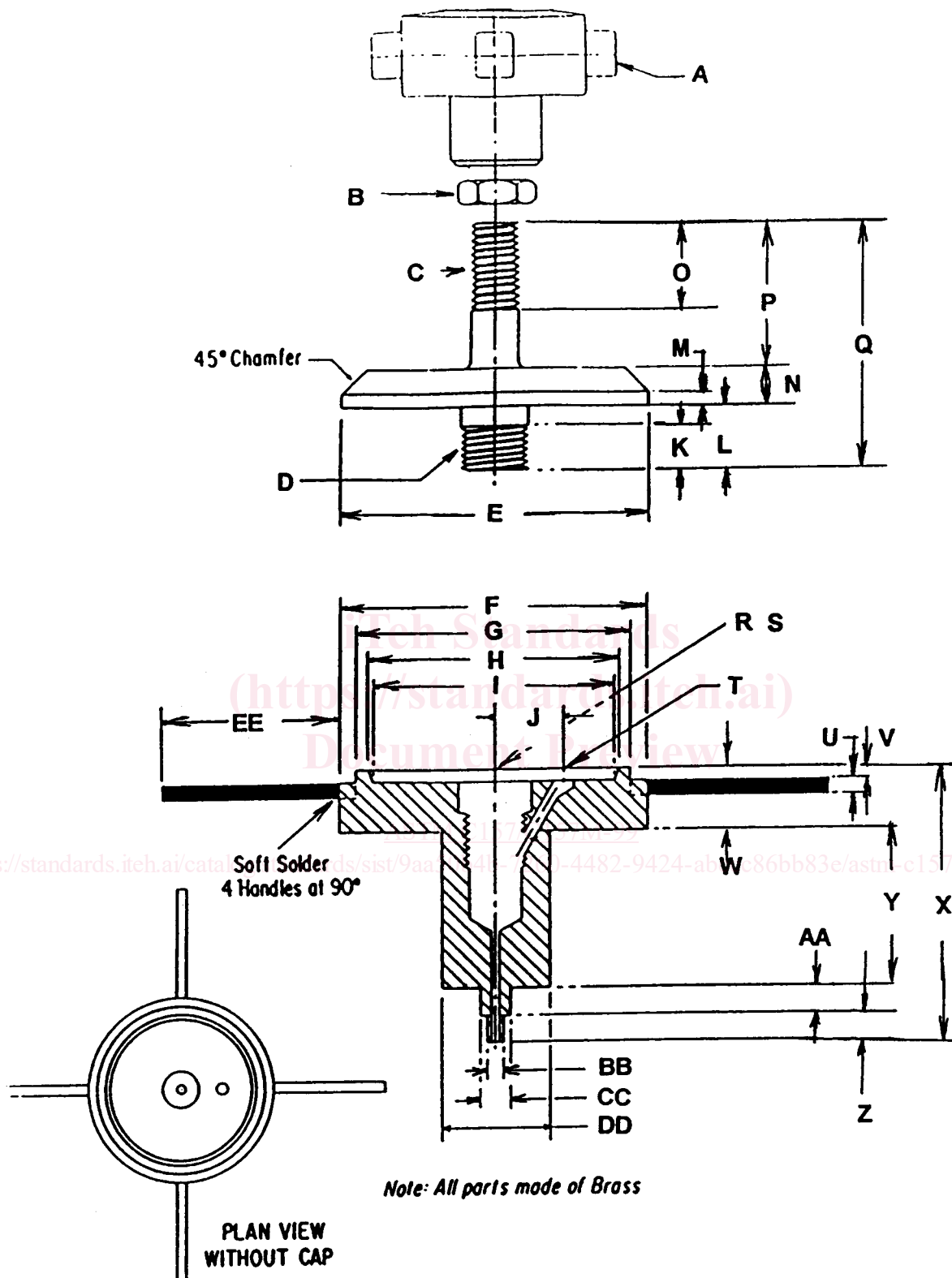

FIG. 1 Atmometer

reported clearly and prominently with comparator values.

5. Apparatus

5.1 *Molds and Length Comparator*—The molds for casting test specimens and the length comparator for measuring length

change shall conform to the requirements of Specification C 490.

5.2 *Tamper*—The tamper shall be made of a nonabsorptive, nonabrasive material such as medium-hard rubber or seasoned oak wood rendered nonabsorptive by immersion for 15 min in

ASTM C 157/C 157M

paraffin at approximately 392°F [200°C], and shall have a cross section of ½ by 1.0 in. [13 by 25 mm] and a convenient length of about 6 in. [150 mm]. The tamping face of the tamper shall be flat and at right angles to the length of the tamper.

5.3 *Tamping Rod*—The tamping rod shall be a straight steel rod ⅜ in. [10 mm] in diameter and not less than 10 in. [250 mm] in length, having at least the tamping end rounded to a hemispherical tip of the same diameter.

5.4 *Drying Room and Controls*—A drying room with suitable racks shall be provided for storing specimens in air. The racks shall be designed for free circulation of air around specimens, except for necessary supports, and shall be so situated with respect to the nearest wall or other obstruction that air circulation is not restricted in the intervening space. The supports shall be horizontal and shall consist of two nonabsorptive members not deeper than 1 in. [25 mm] and having a bearing area of not more than ¼ in. [6 mm] in width. Conditioned air shall be circulated into and out of the room in a uniform manner so that the specified rate of evaporation is attained adjacent to all specimens.

5.4.1 The air in the room shall be maintained at a temperature of 73 ± 3°F [23 ± 2°C] and a relative humidity of 50 ± 4 %. The air movement past all specimens shall be such that the rate of evaporation is 77 ± 30 mL/24 h from an atmometer or 13 ± 5 mL/24 h from a 400-mL Griffin low-form beaker filled to ¾ in. [20 mm] from the top. The temperature and relative humidity of the air in the room shall be measured with either a sling or Assmann psychrometer at least twice each working day. The psychrometer shall comply with Test Method E 337, except that thermometers having an over-all length of 10 in. [250 mm] and marked in subdivisions of 0.5°F [0.25°C] can be used. The room shall be equipped with a means of measuring and recording wet- and dry-bulb temperatures continuously. Correction factors as indicated by the sling or Assmann psychrometer shall be applied to the recorded data. The rate of evaporation within the room shall be determined daily by the use of the atmometer or by the loss of mass of water from a 400-mL Griffin low-form beaker filled initially to ¾ in. [20 mm] from the top.

5.5 *Atmometer*—The atmometer shall be constructed as shown in Fig. 1.

5.5.1 *Mounting*—Fig. 2 shows a suggested arrangement for operating the atmometer. Punch a central hole ½ in. [13 mm]

in diameter in a filter paper, place it on the atmometer, and secure it in place while dry, by turning the torque handle only, until it just starts to slip. Mount the atmometer on a stand with the filter paper in a horizontal position. Mount a 100-mL glass graduate so that the 100-mL mark is from 1 to 3 in. [25 to 75 mm] below the level of the filter paper. Stopper the graduate so that entrance is provided for two short glass tubes not extending to the water level and one long tube extending to the bottom of the graduate. Connect the glass tubing leading from the bottom of the graduate to the inlet of the atmometer by means of clear plastic tubing.

5.5.2 *Operation*—Use clear plastic tubing to connect a squeeze bottle containing distilled or deionized water to one of the short glass tubes into the graduate. Force water into the graduate until it is about half full and then close the remaining glass tube into the graduate. Continue to force water through the graduate into the atmometer until the filter paper is saturated and there are no air bubbles in the system. Open the glass tube into the graduate and release pressure on the squeeze bottle gradually to avoid trapping air in the tube leading to the atmometer. Adjust the level of water in the graduate to approximately the 100-mL mark. If the atmometer is to be used under variable temperature conditions, disconnect the squeeze bottle after filling the graduate to avoid the possibility of additional water being forced into the graduate. Permit evaporation of water from the filter paper for 1 h before recording the time and initial reading of the graduate. This waiting period may be omitted during subsequent use of the atmometer provided the filter paper does not become dry. Change the filter paper whenever it shows signs of contamination but not less frequently than once every two weeks.

5.6 *Filter Paper*—The filter paper to be used with the atmometer shall be white with a smooth surface texture. It shall be 6 in. [152 mm] in diameter and 0.050 ± 0.003 in. [1.27 ± 0.08 mm] thick and shall have a cotton fiber content of not less than 75 weight %. The density shall be between 0.400 and 0.425 g/cm³. The Mullen bursting strength shall not be less than 50 psi [345 kPa].

NOTE 1—E and D filter paper No. 625⁶ has been found suitable.

5.7 *Apparatus for Demolding Specimens*—An apparatus for demolding specimens molded in double molds may be constructed as detailed in Fig. 3 or to a different design that serves the same purpose. When this device is to be used, the center side plate of the double mold must be appropriately drilled and tapped to receive the 8-32 by ⅝ in. [4.5-0.74 IMC by 16 mm] machine screw of the demolding thumb screw. Fig. 4 shows the details of an apparatus for demolding specimens molded in single molds.

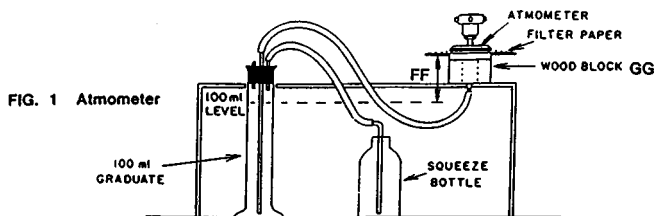

FIG. 2 Atmometer Assembly

⁶ Manufactured by and available for Eaton-Dikeman Co., Mt. Holly Springs, PA 17065.