



Standard Test Methods for Strength of Glass by Flexure (Determination of Modulus of Rupture)¹

This standard is issued under the fixed designation C 158; the number immediately following the designation indicates the year of original adoption or, in the case of revision, the year of last revision. A number in parentheses indicates the year of last reapproval. A superscript epsilon (ϵ) indicates an editorial change since the last revision or reapproval.

1. Scope

1.1 These test methods cover the determination of the modulus of rupture in bending of glass and glass-ceramics.

1.2 These test methods are applicable to annealed and prestressed glasses and glass-ceramics available in varied forms. Alternative test methods are described; the test method used shall be determined by the purpose of the test and geometric characteristics of specimens representative of the material.

1.2.1 Test Method A is a test for modulus of rupture of flat glass.

1.2.2 Test Method B is a comparative test for modulus of rupture of glass and glass-ceramics.

1.3 The test methods appear in the following order:

Test Method A	Sections
Test Method B	6 to 9
	10 to 15

1.4 *This standard does not purport to address all of the safety concerns, if any, associated with its use. It is the responsibility of the user of this standard to establish appropriate safety and health practices and determine the applicability of regulatory limitations prior to use.* Specific hazard statements are given in Section 10 and A1.5, A2.3.3, A2.4.3 and A2.5.3.

2. Referenced Documents

2.1 ASTM Standards:

C 148 Test Methods for Polariscopic Examination of Glass Containers²

E 4 Practices for Load Verification of Testing Machines³

E 380 Practice for Use of the International System of Units (SI) (the Modernized Metric System)⁴

3. Terminology

3.1 Definitions:

3.1.1 *glass-ceramics*—solid materials, predominantly crystalline in nature, formed by the controlled crystallization of glasses.

3.1.2 *modulus of rupture in bending*—the value of maximum tensile or compressive stress (whichever causes failure) in the extreme fiber of a beam loaded to failure in bending computed from the flexure formula:

$$S_b = \frac{M c}{I} \quad (1)$$

where:

M = maximum bending moment, computed from the maximum load and the original moment arm,

c = initial distance from the neutral axis to the extreme fiber where failure occurs, and

I = initial moment of inertia of the cross section about the neutral axis.

3.1.3 *prestressed*—material in which a significant and controlled degree of compressive stress has been deliberately produced in the surfaces.

3.1.4 *standard laboratory atmosphere*—an atmosphere having a temperature of $23 \pm 2^\circ\text{C}$ and a relative humidity of $40 \pm 10\%$.

3.2 Definitions of Terms Specific to This Standard:

3.2.1 *abraded*—describes a test specimen that has at least a portion of the area of maximum surface tensile stress subjected to an operationally defined procedure for mechanical abrasion. The severity and uniformity of abrasion should be sufficient to ensure origin of failure substantially in the region of maximum stress.

3.2.2 *annealed glass*—describes a specimen that shall not have a temper or degree of residual stress resulting from prior thermal treatment in excess of the following limits when measured polarimetrically (see Annex A1):

3.2.2.1 Specimens of rectangular section shall not have a tensile stress at the midplane of more than 1.38-MPa (200-psi) nor more than 2.76-MPa (400-psi) compression at the surface.

3.2.2.2 Specimens in rod form may be examined by viewing through a diameter at least four diameters from an end. The *apparent* central axial tension shall not exceed 0.92 MPa (133 psi). Surface compression, if measured on sections cut from the rods, shall not exceed 2.76 MPa (400 psi) when viewed axially.

¹ These test methods are under the jurisdiction of ASTM Committee C-14 on Glass and Glass Products and are the direct responsibility of Subcommittee C14.04 on Physical and Mechanical Properties.

Current edition approved Sept. 10, 1995. Published November 1995. Originally published as C 158 – 40 T. Last previous edition C 158 – 84 (1989) ϵ^1 .

² *Annual Book of ASTM Standards*, Vol 15.02.

³ *Annual Book of ASTM Standards*, Vol 03.01.

⁴ *Annual Book of ASTM Standards*, Vol 14.02.

4. Significance and Use

4.1 For the purpose of this test, glasses and glass-ceramics are considered brittle (perfectly elastic) and to have the property that fracture normally occurs at the surface of the test specimen from the principal tensile stress. The modulus of rupture is considered a valid measure of the tensile strength subject to the considerations discussed below.

4.2 It is recognized that the modulus of rupture for a group of test specimens is influenced by variables associated with the test procedure. These include the rate of stressing, test environment, and the area of the specimen subjected to stress. Such factors are specified in the test procedure or required to be stated in the report.

4.3 It is also recognized that the variables having the greatest effect on the modulus of rupture value for a group of test specimens are the condition of the surfaces and glass quality near the surfaces in regard to the number and severity of stress-concentrating discontinuities or flaws, and the degree of prestress existing in the specimens. Each of these can represent an inherent part of the strength characteristic being determined or can be a random interfering factor in the measurement.

4.4 Test Method A is designed to include the condition of the surface of the specimen as a factor in the measured strength. It is, therefore, desirable to subject a fixed and significant area of the surface to the maximum tensile stress. Since the number and severity of surface flaws in glass are primarily determined by manufacturing and handling processes, this test method is limited to products from which specimens of suitable size can be obtained with minimal dependence of measured strength upon specimen preparation techniques. This test method is therefore designated as a test for modulus of rupture of flat glass.

4.5 Test Method B describes a general procedure for test, applicable to specimens of rectangular or elliptical cross section. This test method is based on the assumption that a comparative measurement of strength on groups of specimens is of significance for many purposes, such as determining the effect of environment or stress duration, or the effectiveness of varied prestressing techniques or strengths characteristic of glass-ceramics of differing composition or heat treatment. In this test method the surfaces of the specimens are not assumed

to be characteristic of a product or material, but are considered to be determined by the procedures used to prepare the specimens. Though the stated procedure permits a wide variation in both specimen size and test geometry, it is necessary to use identical test conditions and equivalent procedures for specimen preparation to obtain comparable strength values. The use of a controlled abrasion of the specimen as a final normalizing procedure is recommended for such comparative tests.

4.6 A comparative abraded strength, determined as suggested in Test Method B, is not to be considered as a minimum value characteristic of the material tested nor as directly related to a maximum attainable strength value through test of specimens with identical flaws. The operationally defined abrasion procedure undoubtedly produces flaws of differing severity when applied to varied materials, and the measured comparative strengths describe the relative ability to withstand externally induced stress as affected by the specific abrasion procedure.

5. Apparatus

5.1 *Testing Machine*—The loading mechanism shall be sufficiently adjustable to give the required uniform rate of increase of stress. The load-measuring system shall be essentially free of inertial lag at the loading rates used and shall be equipped with means for retaining indication of the maximum load applied to the specimen. The accuracy of the testing machine shall conform to the requirements of Practice E 4.

5.2 *Bearing Edges*—Cylindrical bearing edges of approximately 3-mm ($1/8$ -in.) radius shall be used for the support of the test specimen and the application of the load. The bearing edges shall be of steel and sufficiently hardened to prevent excessive deformation under load. Two-point loading tests shall be performed with the loading member pivoted about a central transverse axis to ensure equal distribution of load between the two bearing edges. For the testing of specimens of rectangular section, both loading bearing edges and one support bearing edge also shall be provided laterally to compensate for irregularities of the test specimen. Fig. 1 shows a suitable arrangement using pinned bearing edges. In test of specimens of a circular or elliptical section, the fixed cylindrical support edges may have a curvature of approximately 76

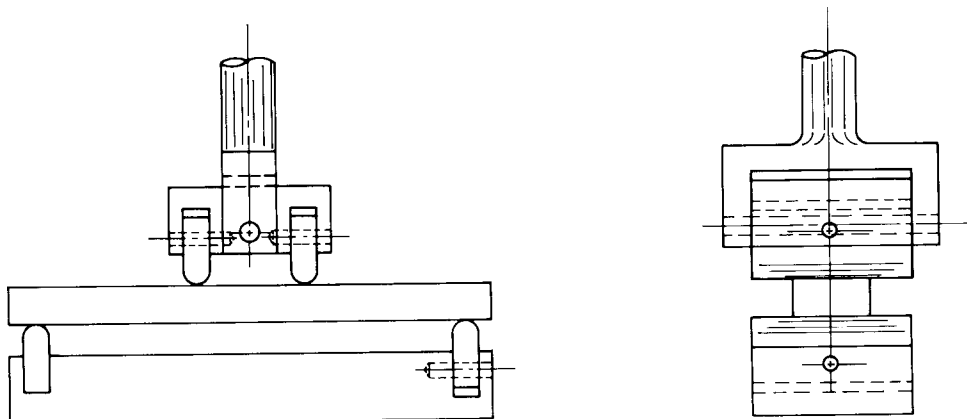

FIG. 1 Pinned Bearing Edges

mm (3 in.) in the plane of the bearing edge to stabilize the alignment of the specimens. Such support edges are shown in Fig. 2.

Carefully place each specimen in the test fixture to minimize possible damage and to ensure alignment of specimen in the fixture. The permissible maximum fiber stress due to initial

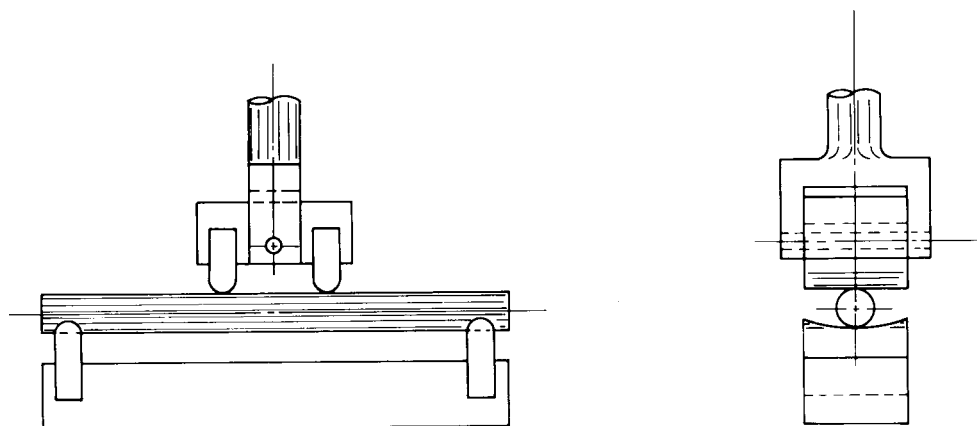

FIG. 2 Fixed Cylindrical Support Edges

TEST METHOD A—TEST FOR MODULUS OF RUPTURE OF FLAT GLASS

6. Test Specimens

6.1 *Preparation of Specimens*—Test specimens shall be cut from the sheet stock with a diamond or a cutting wheel. Both longitudinal cuts shall be on the same original surface and none of the original edge of the sheet shall be used as a longitudinal side of the specimen. End cuts may be on either surface. The direction of cutting of half of the total number of specimens shall be perpendicular to the direction of cutting of the remainder. Specimens that must be cut from sheet stock prior to the use of a prestressing treatment shall have the corners of the longitudinal edges rounded to minimize damage to the edges in the prestressing process. All operations shall be performed with the direction of grind or polish parallel to the longitudinal axis. The radius of the corner shall not exceed 1.6 mm ($1/16$ in.).

6.2 *Size of Specimens*—The specimens shall be approximately 250 mm (10 in.) in length and 38.1 ± 3.2 mm ($1\frac{1}{2} \pm \frac{1}{8}$ in.) in width. The variation in width or thickness shall not exceed 5 % from one end to the other.

6.3 *Number of Specimens*—At least 30 specimens shall be used for one test and shall preferably be taken from several sheets, or regions of a single sheet.

6.4 *Examination of Specimens*—Any specimen may be rejected prior to test for observable defects considered likely to affect the modulus of rupture. To be considered representative of annealed glass the specimens must meet the requirement of 3.2.2. At least 30 % of the specimens shall be examined for residual stress. If any of these fail to meet the requirement, the remainder of the specimens shall be examined and those exceeding the stated limit shall be rejected.

7. Procedure

7.1 Space the supporting edges of the test fixture 200 mm (8.00 in.) apart and centrally position the loading edges with a separation of 100 mm (4.00 in.). Break specimens having cut edges with the cutter marks on the face under compression.

load on the specimen shall not exceed 25 % of the mean modulus of rupture. Load the specimen at a constant rate to failure. For annealed glass the rate of loading shall correspond to a rate of increase of maximum stress of 1.1 ± 0.2 MPa/s ($10\,000 \pm 2000$ psi/min). Test prestressed glasses with the increase of maximum stress per minute between 80 and 120 % of the modulus of rupture. The first six specimens of the group may be tested at a loading rate based on an estimate of the modulus of rupture and the average value for these specimens used to correct this estimate. If range of width and thickness variation in the specimens is less than 5 %, the mean values may be used to represent all specimens for the purpose of calculation of rate of loading.

7.2 Determine the thickness and width of each specimen to ± 1 %. To avoid damage from gaging in the critical area, take measurements prior to testing near each end with a separation equal to the support span, and average the values. Measurements following test shall be in the uniformly stressed region of the specimen.

7.3 Determine the location of point of failure and note it as edge or face origin. Plastic or other tape of low elastic modulus⁵ may be used on the compressive surface to contain the fragmentation and allow observation of point of failure for highly prestressed specimens. Report all values, although segregation of edge break values is permitted.

8. Calculation

8.1 Calculate the modulus of rupture, initial maximum fiber stress, and rate of increase of stress as follows:

8.1.1 Modulus of rupture:

$$S = \frac{3La}{bd^2} \quad (2)$$

8.1.2 Maximum stress due to initial load if present:

$$S_0 = \frac{3L_0a}{bd^2} \quad (3)$$

⁵ Scotch Brand plastic tape, Catalog No. 191-A, manufactured by 3M Co., 3M Center, St. Paul, MN 55144, has been found suitable for this purpose.

8.1.3 Rate of increase of maximum stress:

$$R = \frac{3a}{bd^2} \times \frac{\Delta L}{\Delta t} \quad (4)$$

$$R = S - \frac{S_0}{t}$$

where:

- S = modulus of rupture, MPa (psi),
- S_0 = maximum fiber stress due to initial load if present, MPa (psi),
- R = rate of increase of maximum fiber stress, MPa/s (psi/min),
- L = breaking load including initial load, N (lbf),
- L_0 = initial load, N (lbf),
- a = moment arm or distance between adjacent support and loading edges, mm (in.),
- b = width of specimen, mm (in.),
- d = thickness of specimen, mm (in.),
- t = time from start of continuous loading to rupture, s (min), and
- $\Delta L/\Delta t$ = rate of increase of load, MPa/s (psi/min).

9. Report

9.1 Report the following:

9.1.1 Test method used,

9.1.2 Identification of the glass tested, including any special treatment (for specimens derived from manufacturing processes that are asymmetric in nature; for example, the float process, the side of the sheet placed in tension during test shall be identified, if possible),

9.1.3 Classification as annealed or prestressed glass,

9.1.4 Test environment if other than standard laboratory atmosphere,

9.1.5 Rate of increase of maximum stress,

9.1.6 Value of modulus of rupture for each specimen and designation of point of failure as edge or face, and

9.1.7 Average value of the modulus of rupture for the group and the standard deviation estimate of the mean. Separate values may be determined for edge and face origins.

NOTE 1—See Annex A3 for conversion from inch-pound units and other non-SI units to SI units.

TEST METHOD B—COMPARATIVE TEST FOR MODULUS OF RUPTURE OF GLASS AND GLASS-CERAMICS

10. Hazards

10.1 Care should be exercised in all handling of specimens to avoid the introduction of random and severe flaws.

10.2 Abrasion of specimens of rectangular section should be performed so that corners are not subjected to abrasion. Abrasion should be limited to the region of uniform tensile stress between the loading edges, and it should cover a significant fraction of this area.

10.3 Following an abrasion procedure, a minimum time of 1 h must elapse before taping or testing of specimens (see A2.2).

10.4 Deflectometers, if used during testing, should not contact the tension face of the specimen.

10.5 If tests are performed at temperatures deviating from ambient, it is necessary to allow the specimen to reach thermal

equilibrium to eliminate the presence of thermally induced stresses in the specimen. The report should indicate the thermal history prior to testing.

11. Test Specimens

11.1 *Preparation of Specimens:*

11.1.1 Specimens of rectangular cross section may be prepared by any sequence of conventional operations such as cutting, sawing, grinding, or polishing. Longitudinal edges on the face to be placed in tension should be chamfered or rounded. The corner radius shall be a minimum value sufficient to eliminate edge breaks and shall not exceed one tenth the thickness in specimens approaching a square cross section. Specimens shall have equivalent size and manufacturing procedures in groups to be compared. The specimen length shall be at least 12.7 mm (½ in.) greater in length than the support span used in test. The width to thickness ratio is recommended to be between 2:1 and 10:1. The minimum width shall be 9.5 mm (¾ in.), although specimens of greater width are desirable. The variation in width or thickness shall not exceed 3 % over the length of the specimen equal to the support span.

11.1.2 Specimens in rod form may be prepared as drawn cane or by procedures such as core drilling and centerless grinding. Equivalent sizes and manufacturing procedures shall be used on specimens for comparison. The specimen length shall be at least 12.7 mm (½ in.) greater than the support span used in the test. The diameter shall be optional, with a minimum value of 4.76 mm (⅜ in.). The variation in a measured diameter shall not exceed 3 % over the length of the specimen equal to the support span. The length-to-diameter ratio shall be greater than 10:1. Specimens may be elliptical in section, but the minor diameter shall not be less than 80 % of the major diameter. The specimen shall be straight within 3 mm in 100 mm (or ⅛ in. in 4 in.). The curvature shall be limited to a single plane containing the major or minor diameter of any ellipticity, if this ellipticity exceeds 5 %.

11.2 *Number of Specimens:*

11.2.1 It is recommended that at least 30 specimens shall be available for one test if a controlled abrasion procedure is not used as a normalizing procedure. Utilization of fewer specimens is permissible if conclusions of satisfactory statistical validity are possible, though a minimum of ten specimens is required.

11.2.2 At least 10 specimens shall be used for one test if a controlled abrasion is used to normalize the surface condition of the specimens.

11.3 *Examination of Specimens:*

11.3.1 Any specimens may be rejected prior to testing for defects considered likely to affect the modulus of rupture.

11.3.2 Specimens of glass described as annealed must meet the requirements of 3.2.2. At least 30 % of the specimens shall be examined for residual stress. If any of these are not within the requirements, the remainder of the specimens shall be examined and those exceeding the stated limit shall be rejected.

12. Test Conditions

12.1 *Specimens of Rectangular Section*—The moment arm or separation of adjacent support and loading edges shall be greater than the width of the specimen and at least four times