**Reciprocating internal combustion engine
driven alternating current generating
sets —**

Part 10:

Measurement of airborne noise by the
enveloping surface method

iTeh STANDARD PREVIEW
(standards.iteh.ai)

*Groupes électrogènes à courant alternatif entraînés par moteurs alternatifs
à combustion interne —*

Partie 10: Mesurage du bruit aérien par la méthode de la surface enveloppe

<https://standards.iteh.ai/catalog/standards/sist/e98a8061-4171-4382-96c5-4816ac1657dc/iso-8528-10-1998>



Foreword

ISO (the International Organization for Standardization) is a worldwide federation of national standards bodies (ISO member bodies). The work of preparing International Standards is normally carried out through ISO technical committees. Each member body interested in a subject for which a technical committee has been established has the right to be represented on that committee. International organizations, governmental and non-governmental, in liaison with ISO, also take part in the work. ISO collaborates closely with the International Electrotechnical Commission (IEC) on all matters of electrotechnical standardization.

International Standards are drafted in accordance with the rules given in the ISO/IEC Directives, Part 3.

Draft International Standards adopted by the technical committees are circulated to the member bodies for voting. Publication as an International Standard requires approval by at least 75 % of the member bodies casting a vote.

This part of ISO 8528 was prepared by ISO Technical Committee ISO/TC 70, *Internal combustion engines*.

ISO 8528 consists of the following parts under the general title *Reciprocating internal combustion engine driven alternating current generating sets*:

- Part 1: Application, ratings and performance
- Part 2: Engines
- Part 3: Alternating current generators for generating sets
- Part 4: Controlgear and switchgear
- Part 5: Generating sets
- Part 6: Test methods
- Part 7: Technical declarations for specification and design
- Part 8: Requirements and tests for low-power generating sets
- Part 9: Measurement and evaluation of mechanical vibrations
- Part 10: Measurement of airborne noise by the enveloping surface method
- Part 11: Dynamic, uninterrupted power supply systems
- Part 12: Emergency power supply to safety services

iTeh STANDARD PREVIEW

(standards.iteh.ai)

ISO 8528-10:1998

<https://standards.iteh.ai/catalog/standards/sist/e98a80b1-4f71-4382-96c5-4816ac1657dc/iso-8528-10-1998>

Annex A and the Bibliography of this part of ISO 8528 are for information only.

© ISO 1998

All rights reserved. Unless otherwise specified, no part of this publication may be reproduced or utilized in any form or by any means, electronic or mechanical, including photocopying and microfilm, without permission in writing from the publisher.

International Organization for Standardization
Case postale 56 • CH-1211 Genève 20 • Switzerland
Internet iso@iso.ch

Printed in Switzerland

Reciprocating internal combustion engine driven alternating current generating sets —

Part 10:

Measurement of airborne noise by the enveloping surface method

1 Scope

This part of ISO 8528 defines measurement methods for the determination of airborne noise emitted by reciprocating internal combustion engine driven generating sets in such a way that the total of relevant noise emissions, e.g. exhaust and cooling system noise, together with all other sources of engine noise, are evaluated on a similar basis to yield comparable results. However, when the exhaust and cooling systems are ducted to a remote site their noise contribution is not to be included in this part of ISO 8528.

The essential noise emission characteristic value is the sound power level.

<https://standards.iteh.ai/catalog/standards/sist/e98a80b1-4f71-4382-96c5-4816ac1657dc/iso-8528-10-1998>

The results of measurement taken in accordance with this part of ISO 8528 are classified as either accuracy grade 2 or grade 3 depending on which acoustic measurement conditions are complied with. Accuracy grade 2 (i. e., engineering method in accordance with ISO 3744) requires the measuring area to be a substantially acoustic-free field over a reflecting plane (with an environmental correction $K_{2A} \leq 2$ dB) and with negligible background noise level (background noise correction $K_{1A} \leq 1,3$ dB). Accuracy grade 3 (i. e. survey method in accordance with ISO 3746) requires the environmental correction K_{2A} to be less or equal than 7 dB, and the background noise correction K_{1A} to be less or equal than 3 dB.

For the operation of a generating set under steady conditions this part of ISO 8528 allows for the calculation of the A-weighted sound power level as well as appropriate octave or one third octave sound power level for the appropriate accuracy grade.

This part of ISO 8528 applies to RIC engine driven AC generating sets for fixed and mobile applications with rigid or flexible mountings. It is applicable for land and marine use, excluding generating sets used on aircraft or to propel land vehicles and locomotives.

NOTE 1 This part of ISO 8528 has been developed for RIC engine driven AC generating sets, but it can also be applied to RIC engine driven DC generating sets.

NOTE 2 For some specific applications (e. g. essential hospital supplies, high rise buildings, etc.) supplementary requirements may be necessary. The provisions of this part of ISO 8528 should be regarded as a basis.

NOTE 3 True comparisons can only be made between generating sets when the measurement are classified in the same accuracy grade.

2 Normative references

The following normative documents contain provisions which, through reference in this text, constitute provisions of this part of ISO 8528. For dated references, subsequent amendments to, or revisions of, any of these publications do not apply. However, parties to agreements based on this part of ISO 8528 are encouraged to investigate the possibility of applying the most recent editions of the normative documents indicated below. For undated references, the latest edition of the normative document referred to applies. Members of ISO and IEC maintain registers of currently valid International Standards.

ISO 700:—¹⁾, *Arc welding equipment — Welding power sources.*

ISO 3046-1:1995, *Reciprocating internal combustion engines — Performance — Part 1: Standard reference conditions, declarations of power, fuel and lubricating oil consumptions and test methods.*

ISO 3744:1994, *Acoustics — Determination of sound power levels of noise sources using sound pressure — Engineering method in an essentially free field over a reflecting plane.*

ISO 3746:1995, *Acoustics — Determination of sound power levels of noise sources using sound pressure — Survey method using an enveloping measurement surface over a reflecting plane.*

ISO 8528-1:1993, *Reciprocating internal combustion engine driven alternating current generating sets — Part 1: Application, ratings and performance.*

ISO 8528-2:1993, *Reciprocating internal combustion engine driven alternating current generating sets — Part 2: Engines.*

ISO 9614-1:1993, *Acoustics — Determination of sound power levels of noise sources using sound intensity — Part 1: Measurement at discrete points.*

ISO 9614-2:1996, *Acoustics — Determination of sound power levels of noise sources using sound intensity — Part 2: Measurement by scanning.*

ISO 11203:1995, *Acoustics — Noise emitted by machinery and equipment — Determination of emission sound pressure levels at a work station and at other specified positions from the sound power level.*

IEC 60804: 1985, *Integrating-averaging sound level meters.*

3 Terms and definitions

For the purposes of this part of ISO 8528 the following terms and definitions apply:

- for acoustics, those in accordance with ISO 3744 and ISO 3746;
- for the reciprocating internal combustion engine the terms in accordance with ISO 3046-1;
- for generating sets the terms in accordance with ISO 8528-1 and ISO 8528-2.

1) To be published. (Revision of ISO 700:1982)

4 Symbols

| | |
|---------------------|---|
| i | Subscript denoting a particular measuring point |
| K_{1A} | Background noise correction |
| K_{2A} | Environmental correction |
| $\overline{L_p}$ | Average octave or one third octave sound pressure level after correction for background noise and environmental influence in decibels |
| $\overline{L_{pA}}$ | Averaged A-weighted sound pressure level after correction for background noise and environmental influence in decibels |
| L_{pAi} | A-weighted sound pressure level at measuring point i in decibels |
| L_{pi} | Octave or one third octave sound pressure level at measuring point i in decibels |
| L_S | Measuring surface dimension |
| L_{WA} | A-weighted sound power level |
| L_{Woct} | Octave sound power level |
| $L_{W1/3 oct}$ | One third octave sound power level |
| n | Number of measuring points |
| S | Measuring surface |
| S_0 | Reference measuring surface |
| ΔL_p | Difference of sound pressure level in decibels |
| ΔL_{WA} | Difference of A-weighted sound power level |
| $\cos\varphi$ | Power factor |

5 Other regulations and requirements

5.1 For generating sets used on board ships and offshore installations which have to comply with the rules of a classification society, the additional requirements of the classification society shall be observed. The classification society shall be stated by the customer prior to placing the order.

For nonclassified generating sets, such additional requirements are in each case subject to agreement between the manufacturer and customer.

5.2 If special requirements from regulations of any other authority, e. g. inspecting and/or legislative authorities, have to be met, the authority shall be stated by the customer prior to placing the order.

Any further additional requirements shall be subject to agreement between the manufacturer and customer.

6 Designation of the method

The method of noise measurement according to this part of ISO 8528, grade 2, is designated as follows.

Noise measurement ISO 8528-10 grade 2.

The method of noise measurement according to this part of ISO 8528, grade 3, is designated as follows.

Noise measurement ISO 8528-10 grade 3.

7 Measuring equipment

The requirements for measuring equipment are those in accordance with ISO 3744 and ISO 3746.

8 Measuring object

The noise of a generating set is defined as the total noise emitted by that generating set. This includes the surface noise of the engine and the generator, the inlet noise, exhaust noise and the noise emitted from the cooling system of the engine and the fan of the generator and also the noise which will, for example, be emitted from the joining sections and the baseframe.

In case of totally or partially encapsulated generating sets the surface noise is the noise emitted from the enclosure.

If, in a special case, one of the above mentioned noise emissions is not in the measurement results then this shall be recorded in the measuring report.

ISO 8528-10:1998

<https://standards.iteh.ai/catalog/standards/sist/e98a80b1-4f71-4382-96c5-4816ac1657dc/iso-8528-10-1998>

9 Operating conditions of the generating set

9.1 General

The generating set shall be prepared in accordance with the instructions given by the manufacturer.

In practice the same generating set is operated under various operating conditions depending upon application and conditions on site, therefore other operating conditions as laid down in 9.2 or 9.3 may be used.

For the torque a tolerance of $\pm 10\%$ is acceptable for the acoustic results.

When the measurements are taken, the ambient and air inlet temperatures shall be not higher than 320 K. The generating set speed, average electrical power output, ambient temperature and type of fuel and cetane index used during the test shall be recorded in the measuring report because of their influence on the noise emission.

9.2 Generating set (power generator)

The generating set shall operate at a steady power output at 75 % of its rated power in kilowatts.

The given output, i.e. the useful output calculated on the basis of the given output in kilovoltamperes under the application of the power factor ($\cos \varphi$) shall be reported.

NOTE The operating conditions given here are identical to those defined in EEC Council Directive 84/536/EEC (currently under revision)

9.3 Generating set (welding generator)

This shall be driven as specified in accordance with ISO 700 and produce its rated welding output against a resistance.

NOTE The operating conditions given here are identical to those defined in EEC Council Directive 84/535/EEC (currently under revision)

9.4 Mounting of the generating set

The generating set should be installed on a typical noise-reflecting ground plane of concrete or nonporous asphalt. The distance from the source to the next wall of the test cell should be twice the distance between source and microphone. Trailer mounted units should be installed according to the manufacturer's recommendation.

10 Measuring surface, measuring distances and measuring points

See figures 1 to 4.

10.1 Reference hemisphere and measuring surface

For measuring the sound power level in a hemisphere, the requirement of the EC-Directives 84/535/EEC and 84/536/EEC shall be met.

10.2 Reference parallelepiped and measuring surface

A reference grid shall be established on the surfaces of the smallest possible hypothetical parallelepiped around the generating set. Elements protruding from the engine and which are not significant emitters of sound energy may be disregarded.

For safety reasons the reference grid may be enlarged to remove measuring points from the dangerous areas, for example hot surfaces and moving parts. The measuring surface follows this rectangular surface at a distance, "d", and finishes at a noise-reflecting surface on the mounting.

10.3 Measuring distance

The measuring distance, "d", between the reference parallelepiped and the measuring surface is 1 m. In cases where this is not possible the measuring distance shall be at least 0,5 m. Greater measuring distances can only be used if environmental conditions in accordance with ISO 3744 and ISO 3746 apply.

10.4 Number and arrangement of measuring points

Basically the measuring points should be arranged equidistantly along the measuring surface and completely enclose the noise area. The number depends upon the size of the generating set and the uniformity of the noise field. The arrangement and the number of the measuring points on the measuring surface depends on the measurements l_1 , l_2 and l_3 of the reference grid and are shown in figures 1 to 4.

The arrangement of measuring points for the accuracy grades 2 and 3 do not differ. The measuring points shown in figures 2, 3 and 4 are, compared with those in ISO 3744 and ISO 3746, simplified.

Preliminary investigations have shown that for the appropriate generating sets the A-weighted sound power level determined as a result of the measurement at only five measuring points (measuring points 1, 2, 3, 4 and 9 in figure 1), is normally higher than with the arrangement at nine measuring points by a level difference $\Delta L_{WA}^{(2)}$

2) Numerous tests have shown that for different types of engine, ΔL_{WA} has a value between 0,7 dB and 1,8 dB.

For a given type of engine, preliminary investigations shall be made to show that the range of ΔL_{WA} does not exceed 0,5 dB, otherwise the measuring points cannot be reduced to five points only.

In relation to figures 2, 3 and 4, for the engineering and survey method the number of microphone positions specified is less than that specified in ISO 3744 and ISO 3746. Preliminary investigations have shown that in all cases for the types of engines concerned, the A-weighted surface sound pressure levels from these reduced arrays differ by less than 0,5 dB in comparison with the full arrays.

Should one of the measuring points shown in the figures not be accessible due to lack of space or other reasons, the measuring point on the measuring plane can be moved along its measuring surface, provided that the distance from the previous measuring position be as small as possible. The position of the altered measuring point shall be shown in the measurement report.

In the area of the inlet air and exhaust gas openings, microphones shall be arranged so that they will not encounter air/gas movements. At present the simplified measuring method is not available for generating sets larger than that shown in figure 1 due to lack of expertise.

For all measuring points the following apply.

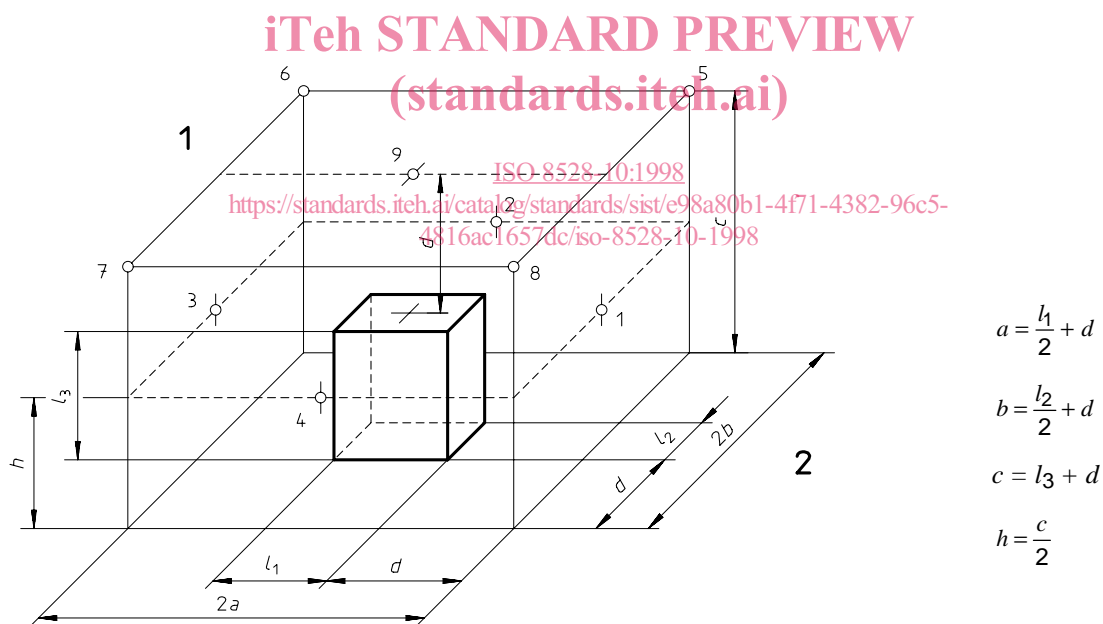

Key

- 1 Engine side
- 2 Generator side

Figure 1 — Measuring point arrangement (nine measuring points) and measuring plane for generating sets with the reference rectangle measurements: $l_1 < 2$ m; $l_2 < 2$ m; $l_3 < 2,5$ m

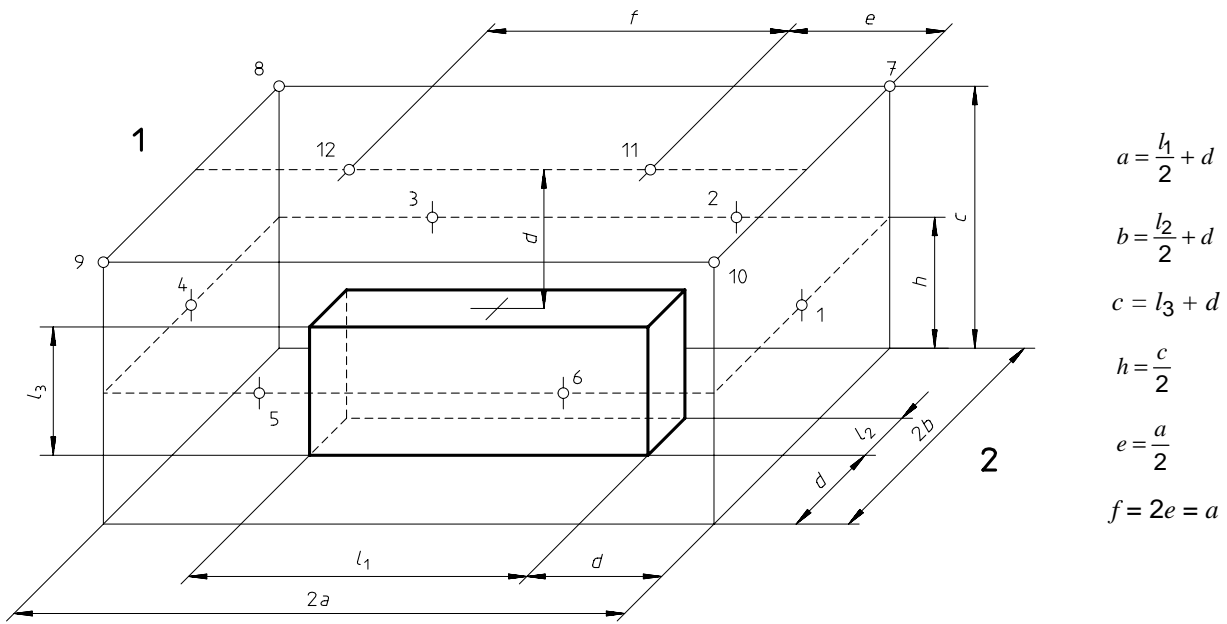

Key

- 1 Engine side
- 2 Generator side

iTeh STANDARD PREVIEW

(standards.itech.ai)

Figure 2 — Measuring point arrangement (12 measuring points) and measuring plane for generating sets with the reference rectangle measurements: $2\text{ m} < l_2 < 4\text{ m}$; $l_3 \leq 2,5\text{ m}$

ISO 8528-10:1998

<https://standards.itech.ai/catalog/standards/sist/e98a80b1-4f71-4382-96c5-4816ac1657dc/iso-8528-10-1998>

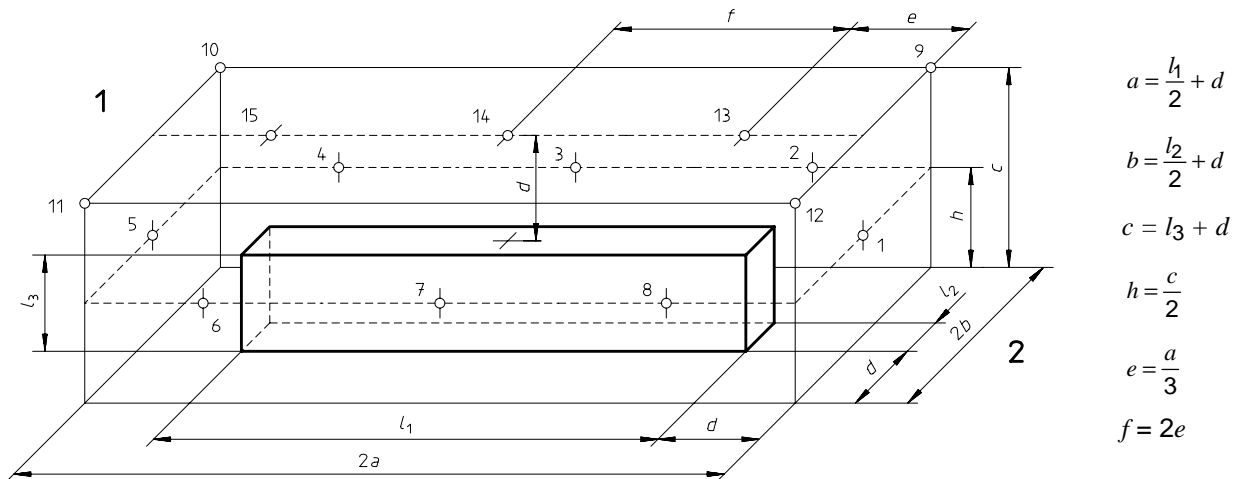

Key

- 1 Engine side
- 2 Generator side

Figure 3 — Measuring point arrangement (15 measuring points) and measuring plane for generating sets with the reference rectangle measurements: $l_1 > 4\text{ m}$; $l_3 \leq 2,5\text{ m}$