



Standard Test Methods for Thickness and Density of Blanket or Batt Thermal Insulations¹

This standard is issued under the fixed designation C 167; the number immediately following the designation indicates the year of original adoption or, in the case of revision, the year of last revision. A number in parentheses indicates the year of last reapproval. A superscript epsilon (ϵ) indicates an editorial change since the last revision or reapproval.

This standard has been approved for use by agencies of the Department of Defense.

1. Scope

1.1 These test methods cover the determination of thickness and density of flexible, felted, or woven thermal insulating blankets, rolls, or batts composed of fibrous materials, with or without surface covering or reinforcement.

1.2 *This standard does not purport to address all of the safety concerns, if any, associated with its use. It is the responsibility of the user of this standard to establish appropriate safety and health practices and determine the applicability of regulatory limitations prior to use.*

2. Referenced Documents

2.1 *ASTM Standards:*

C 168 Terminology Relating to Thermal Insulation Materials²

3. Terminology

3.1 *Definitions*—Terminology C 168 shall be considered as applicable to the terms used in these test methods.

4. Significance and Use

4.1 Proper measurements of thickness and density of blanket or batt insulations are essential for determining thermal insulation properties. For a particular batt or blanket product, thickness and density are usually directly related to thermal insulating value.

4.2 These test methods are of significant value in manufacturing quality control, to ensure that claimed insulation values of products are maintained.

5. Apparatus

5.1 *Depth Gage*, of the type shown in Fig. 1. The disk shall be fabricated of a suitable clear plastic material, so that the operator can see when contact is made with the insulation. The disk shall be perpendicular to the pin at all times and shall have a friction device to grip the pin unless purposely moved. The pin shall be of sufficient length for the material to be measured.

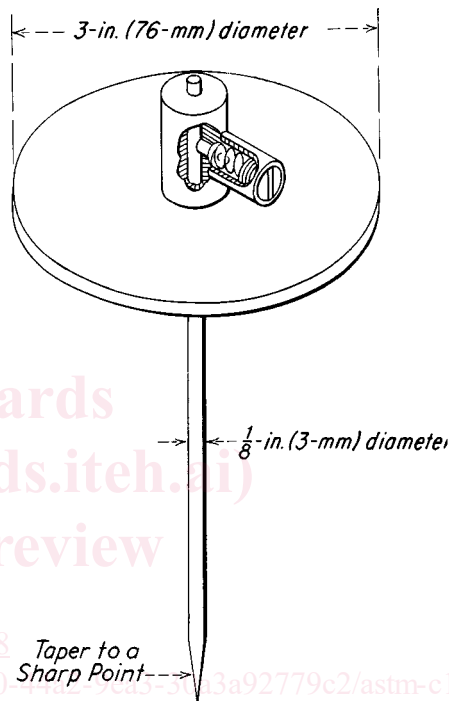

FIG. 1 Depth Gage for Thickness Measurements

5.2 *Steel rule*, graduated in 0.05-in. or 1-mm intervals.

5.3 *Scales*, of sufficient capacity and sensitivity to weigh the test specimen to an accuracy of $\pm 0.5\%$.

6. Sampling

6.1 A test sample shall consist of one representative roll or bundle of insulation.

6.2 *Sampling of Bundles*—For bundles which contain 20 or more batts, five batts shall be selected. Otherwise, either the three-batt or five-batt selection technique may be used. Batt which are folded in half shall count as two batts for purposes of choosing and employing the selection method.

6.2.1 *Three-Batt Method*—Select the center batt and the second batt in from each end of the package.

6.2.2 *Five-Batt Method*—Divide the package sequentially into five groups of batts as equal in number as possible. Select the first batt from each group. Be careful to select one and only one batt from the two end batts within the package.

¹ These test methods are under the jurisdiction of ASTM Committee C-16 on Thermal Insulation and are the direct responsibility of Subcommittee C16.32 on Mechanical Properties.

Current edition approved August 10, 1998. Published November 1998. Originally published as C 167 – 41. Last previous edition C 167 – 93.

² *Annual Book of ASTM Standards*, Vol 04.06.

6.2.3 Cut batts which are longer than 48 in. to 48 ± 0.25 in. (122 ± 0.63 cm) in length.

6.3 *Sampling of Cut Rolls*—Five batts will be cut of roll-width by 48 ± 0.25 in. (122 ± 0.63 cm) in length.

6.3.1 Cut one batt from the center of the roll, two batts from the ends of the roll, and the fourth and fifth from the quarter points along the length.

6.3.2 For blankets wider than 24 in., cut each of the five batts 24 ± 0.25 in. (61 ± 0.63 cm) wide by 48 ± 0.25 in. (122 ± 0.63 cm) long.

6.4 *Sampling for Full Roll Method*—This method can be used in place of 6.3 when the roll is wider than 24 in. (61 cm) or longer than 50 ft (16.4 m). Prior to unrolling the material, weigh the entire roll to the nearest 0.25 pound (0.11 kg). Two methods may be used to obtain the full roll weight. The first method removes the insulation product from the packaging prior to weighing. The material will expand and may unroll slightly, care must be taken to ensure that the full roll is weighed accurately. The second method weighs the packaged insulation product, then weighs the packaging material only. The packaging material weight is subtracted from packaged product weight to obtain net material weight.

7. Procedure

7.1 *Expansion of Bundles and Cut Roll*—Hold the first batt vertically off the floor by grasping it with both hands on its long dimension so that the lower edge is 18 ± 1 in. (460 ± 25 mm) above the floor. Release the batt, allowing it to strike the floor. Repeat the above for a second time. Next, holding the batt by the other long edge, drop twice as above. Place the specimen on a flat, hard surface. Repeat the above for the remaining four specimens. Allow specimens to reach equilibrium by waiting at least 5 min before making thickness measurements within 1 in. (25 mm) in any direction of five points as indicated in Fig. 2.

NOTE 1—If 23-in. (580-mm) wide samples are tested, use a quarter or

half of that dimension to establish the test points.

NOTE 2—Some materials may require 4 h or more to reach equilibrium.

7.2 *Expansion of Full Roll*—Unroll the insulation. Flip the test roll over its entire length so the bottom surface is now on top. Next grasp one end and pull the material over itself until the original surface is again facing up. If there is insufficient room to pull the material over itself (less than twice the unrolled length), the material may be repositioned by sliding the partially pulled roll to the end of the testing space, and continue to pull the material over itself.

NOTE 3—Use Section 7.1 if sampling procedure in Section 6.3 is used.

7.3 *Measurement of Bundles and Cut Roll*—Insert the pin of the thickness gage vertically into the material at the first measuring point with a twisting motion until it contacts the hard surface beneath. Lower the disk until it lightly and uniformly contacts the specimen. An alternative procedure is to use a disk whose mass exerts a specified pressure of at least 0.4 lbf/ft² (20 Pa) on the specimen. With the gage disk locked against the pin, lift the gage unit from the test specimen. While holding the gage in locked position, place the disk against the zero end of the rule with the pin projecting along the calibrated surface of the rule. Observe and record the reading at the pointed end of the pin to the nearest 0.05 in. (1 mm). Repeat the above for each of the remaining measuring points as shown in Fig. 2.

7.4 *Measurement of Full Roll*—Record the roll length to the nearest 1 in. (2.54) cm. Take measurements on each side of the roll. If the roll has been cut in half, take a third roll length measurement along the midpoint of the roll width. Record roll width at three locations to the nearest 0.125 in. (0.32 cm). Width measurements will be taken 10 ft (3.05 m) from each end, and in the middle of the roll length. Using a pin gauge, record thickness to the nearest 0.05 in. (1 mm) as shown in Fig. 3. Refer to Section 7.3 for use of pin gauge. Two 15 ft (4.57 m) long sections shall be measured. These sections shall be 10 (3.05 m) in from each end. A total of twenty thickness measurements will be taken for each roll.

NOTE 4—Use Section 7.4 if sampling procedure in Section 6.4 is used.

8. Calculation

8.1 *Thickness*—Take the average of the thickness measurements made in accordance with Section 7 as the thickness of the specimen.

8.2 *Area Weight and Density*—Calculate the weight per unit area and the density by one of the following equations:

$$\text{Weight per unit area as received, lb/ft}^2 \text{ (or kg/m}^2\text{)} = w_1 / (L \times W) \quad (1)$$

$$\begin{aligned} &\text{Weight per unit area without facings, lb/ft}^2 \text{ (or kg/m}^2\text{)} \\ &= w_2 / (L \times W) \end{aligned}$$

$$\begin{aligned} &\text{Density of insulation (without facings), lb/ft}^3 \text{ (or kg/m}^3\text{)} \\ &= w_2 / (L \times W \times T) \end{aligned}$$

$$\begin{aligned} &\text{Density of insulation (without facings) at specified thickness, lb/ft}^3 \\ &\text{(or kg/m}^3\text{)} \end{aligned}$$

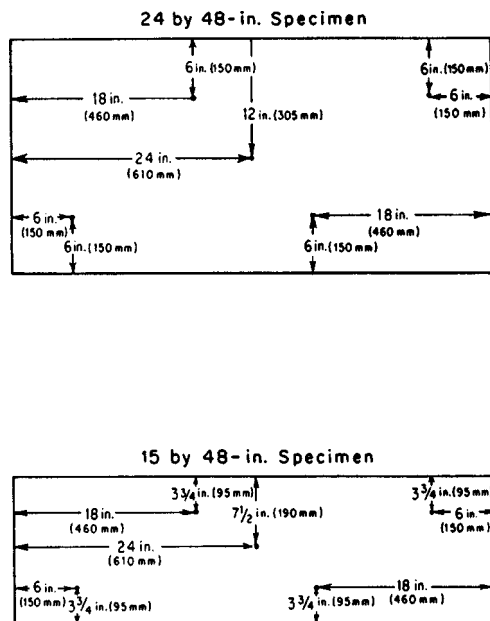

FIG. 2 Thickness Measurement Locations