

INTERNATIONAL STANDARD

ISO 8535-1

Second edition
1990-09-15

Compression-ignition engines — Steel tubes for high-pressure fuel injection pipes —

Part 1 :

Requirements for seamless cold-drawn single-wall
tubes

iTeh STANDARD PREVIEW
(standards.iteh.ai)

*Moteurs à allumage par compression — Tubes en acier pour lignes d'injection à
haute pression*

<https://standards.iteh.ai/catalog/standards/iso/8535-1:1990>
Partie 1 : Caractéristiques des tubes monoparoi sans soudure étirés à froid
e559e878a051/iso-8535-1-1990



Reference number
ISO 8535-1 : 1990 (E)

Contents

	Page
Foreword	iii
1 Scope	1
2 Normative references	1
3 Dimensions and tolerances	1
4 Material processing	3
5 Testing	4
6 Designation	5
7 Identification and marking	6
8 Packing	6
Annex A: Bibliography	7

iTeh STANDARD PREVIEW
(standards.iteh.ai)

[ISO 8535-1:1990](https://standards.iteh.ai/catalog/standards/sist/c144c07e-6fb9-41e1-98f4-e559e878a051/iso-8535-1-1990)

<https://standards.iteh.ai/catalog/standards/sist/c144c07e-6fb9-41e1-98f4-e559e878a051/iso-8535-1-1990>

© ISO 1990

All rights reserved. No part of this publication may be reproduced or utilized in any form or by any means, electronic or mechanical, including photocopying and microfilm, without permission in writing from the publisher.

International Organization for Standardization
Case postale 56 • CH-1211 Genève 20 • Switzerland

Printed in Switzerland

Foreword

ISO (the International Organization for Standardization) is a worldwide federation of national standards bodies (ISO member bodies). The work of preparing International Standards is normally carried out through ISO technical committees. Each member body interested in a subject for which a technical committee has been established has the right to be represented on that committee. International organizations, governmental and non-governmental, in liaison with ISO, also take part in the work. ISO collaborates closely with the International Electrotechnical Commission (IEC) on all matters of electrotechnical standardization.

Draft International Standards adopted by the technical committees are circulated to the member bodies for voting. Publication as an International Standard requires approval by at least 75 % of the member bodies casting a vote.

International Standard ISO 8535-1 was prepared by Technical Committee ISO/TC 22, *Road vehicles*.

This second edition cancels and replaces the first edition (ISO 8535-1 : 1989), of which it constitutes a minor revision.

<https://standards.iteh.ai/catalog/standards/sist/71e07e-3fb9-41e1-984e-559e878a051/iso-8535-1-1990>

ISO 8535 will consist of the following parts, under the general title *Compression-ignition engines — Steel tubes for high-pressure fuel injection pipes*:

- *Part 1: Requirements for seamless cold-drawn single-wall tubes*
- *Part 2: Requirements for composite tubes*

An intended future part 3, dealing with requirements for high-pressure pipe assemblies, will now be published as a separate International Standard.

Annex A of this part of ISO 8535 is given for information only.

iTeh STANDARD PREVIEW
(standards.iteh.ai)

[ISO 8535-1:1990](#)

<https://standards.iteh.ai/catalog/standards/sist/c144c07e-3fb9-41e1-98f4-e559e878a051/iso-8535-1-1990>

Compression-ignition engines — Steel tubes for high-pressure fuel injection pipes —

Part 1 :

Requirements for seamless cold-drawn single-wall tubes

1 Scope

This part of ISO 8535 specifies dimensions and requirements for seamless cold-drawn single-wall steel tubes for high-pressure fuel injection pipes used on compression-ignition (diesel) engines (Class 2) and for fuel injection pump testing (Class 1).

It applies to reciprocating internal combustion compression-ignition engines (diesel engines).

iTeh STANDARD PREVIEW

(standards.iteh.ai)

Tolerances on inside and outside diameters shall be as follows :

a) Inside diameter, d

$d < 4$ mm : $\pm 0,05$ mm for class 2

$\pm 0,025$ mm for class 1¹⁾

$d > 4$ mm : $\pm 0,10$ mm for class 2

NOTE — Classes 1 and 2 are explained in clause 1.

b) Outside diameter, D

$D < 8$ mm : $\pm 0,06$ mm

$D > 8$ mm : $\pm 0,10$ mm

} for classes 1 and 2

c) Concentricity of the tube outside diameter relative to the inside diameter shall be proportional to the wall thickness, as shown in figure 1.

2 Normative references

The following standards contain provisions which, through reference in this text, constitute provisions of this part of ISO 8535. At the time of publication, the editions indicated were valid. All standards are subject to revision, and parties to agreements based on this part of ISO 8535 are encouraged to investigate the possibility of applying the most recent editions of the standards indicated below. Members of IEC and ISO maintain registers of currently valid International Standards.

ISO 404 : 1981, *Steel and steel products — General technical delivery requirements.*

ISO 6892 : 1984, *Metallic materials — Tensile testing.*

3 Dimensions and tolerances

3.1 Diameters

Recommended inside and outside diameters are given in table 1. Other sizes may be used by agreement between supplier and purchaser.

3.2 Length

Length and tolerances on length shall be by agreement between supplier and purchaser.

1) These tolerances are in accordance with ISO 4093.

Table 1 – Recommended inside and outside diameters¹⁾

Dimensions in millimetres

Inside diameter ²⁾ <i>d</i>	Outside diameter, <i>D</i>									
	4	5	6	8	10	12	15	19	24	30
Preferred										
1										
1,12										
1,25										
1,4										
1,5										
1,6										
1,7										
1,8										
1,9										
2										
2,12										
2,24										
2,36										
2,5										
2,65										
2,8										
3										
3,15										
3,35										
3,55										
3,75										
4										
4,25										
4,5										
4,75										
5										
5,3										
5,6										
6										
6,3										
6,7										
7,1										
7,5										
8										
8,5										
9										
9,5										
10										
10,6										
11,2										
11,8										
12,5										

STANDARD PREVIEW
 (standards.iteh.ai)
 ISO 8535-1:1990
<https://standards.iteh.ai/catalog/standards/sist/c144c07e-3fb9-41e1-9874-e559e878a051/iso-8535-1-1990>

1) The diameter sizes of tubes have been established with the ratio of outside to inside diameter within the range of 2 to 4.
 2) Based on ISO 3.

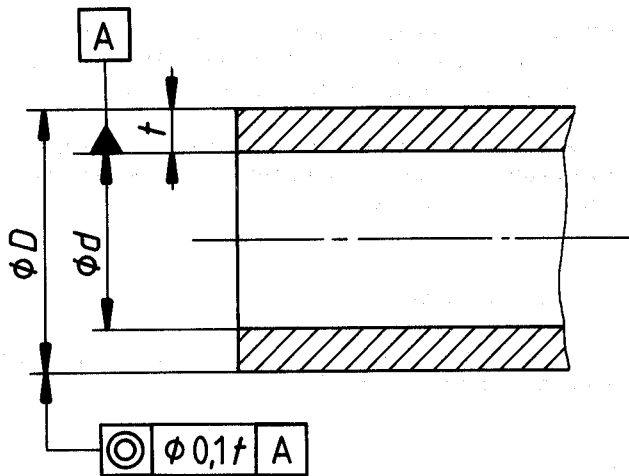

Figure 1

4.3.1 Bore grade S — Basic surface quality of bore

The inside of the tubes shall be finished to ensure a smooth bore of accurate size with no more than five imperfections (fissures, crevices, etc.) over 0,08 mm to 0,13 mm max. deep, per tube cross-section, using $\times 50$ magnification for examination (see table 2).

4.3.2 Bore grades P, Q, R — Increased surface quality of bore

If closer control over the depth of imperfections is required, bore grades P, Q or R, assessed under the magnification indicated (see table 2) may be specified in the tube designation (see clause 6).

4.4 Surface finish

The outside surface of the tube may be coated on delivery by metal plating, galvanizing, or may be submitted to a chemical surface treatment (see table 3).

The inside surface of the tube shall remain uncoated.

4 Material processing

4.1 Steel manufacturing process

The tubes shall be manufactured from an unalloyed quality steel or an equivalent quality steel produced by a steel-making process that ensures a very homogeneous structure.

If requested by the purchaser, the supplier shall state the method of manufacture and the deoxydation process used.

4.2 Manufacturing of tubes

The final reduction(s) of the tube shall be followed by heat treatment to achieve the specified mechanical properties.

4.3 Surface quality

The outside and inside surfaces of finished tubes shall be free from scale, rust, grooves, laps, laminations, deep pits or other injurious defects.

Table 2 — Bore grades

Code	Permitted imperfections	Magnification
S	As in 4.3.1.	$\times 50$
R	A maximum of five imperfections over 0,05 mm to 0,08 mm max. deep.	$\times 100$
Q	A maximum of five imperfections over 0,02 mm to 0,05 mm max. deep.	$\times 100$
P	All imperfections less than 0,02 mm deep.	$\times 200$

Table 3 — Surface finish on delivery

Code	Outside surface condition	Application remarks
0	Not specified (at manufacturer's choice)	May have additional finish at manufacturer's choice
1	Outside surface as-processed, without any additional finish. Tubes annealed or normalized in a controlled atmosphere may be discoloured, but shall be free from loose scale	Condition preferred for further surface processing
2	Zinc electroplated with a coating layer thickness of 8 μm minimum and an additional colourless chromating ¹⁾	When corrosion-resistance is required; not recommended for use with light alcohol-based fuels such as methanol
3	Zinc electroplated with a coating layer thickness of 8 μm minimum and an additional yellow chromating ¹⁾	When corrosion-resistance is required; not recommended for use with light alcohol-based fuels such as methanol
[4, 5, 6, 7, 8]	[Reserved for further application]	
9	As specified subject to agreement between supplier and purchaser	

1) Chromating as described in ISO 2080.

4.5 Mechanical properties of tube

The classes of mechanical properties (codes 1 to 3) resulting from the steel type and delivery condition are listed in table 4, with values of mechanical properties; they are mandatory regardless of possible variations of manufacturing process.

4.6 Cleanliness

The bore shall be clean and free from any contamination or coating which would impair the processing and serviceability of the tubes. Any special requirements shall be agreed at the time of enquiry or order between supplier and purchaser.

4.7 Straightness

Unless otherwise agreed between supplier and purchaser, the tubes shall be straight within a maximum error of 1 in 400 with no localized deformation.

4.8 Corrosion-resistance

The outside and inside surfaces shall be protected against corrosion for transportation and storage in closed areas. A permanent coating may be used on the outside surface when agreed between supplier and purchaser. Any temporary coating used shall not be injurious to the injection and combustion systems of the engine and shall be removable with diesel fuel.

5 Testing

In the absence of any other test agreement between supplier and purchaser, tests shall be carried out in accordance with 5.1 to 5.7.

5.1 Scope of tests

Tubes shall be tested by lots of the same dimensions, steel type, heat treatment and surface texture. Tubes from each heat of steel shall be tested irrespective of lot.

For the test in 5.3, the test inspector shall select one tube from each lot and for the test in 5.5, three tubes. The tests in 5.2, 5.6.1 and 5.7 shall be performed on all selected tubes.

For the tests in 5.6.2 the lot size, the number of samples and the acceptance limit shall be agreed upon between the supplier and purchaser in the order.

5.2 Dimension tests

The tube dimensions shall comply with the dimensions and tolerances indicated in clause 3.

5.3 Mechanical property tests

The tubes shall comply with the specifications given in table 4. The tests shall be made according to ISO 6892. Tensile strength, yield stress, elongation and hardness shall be measured.

5.4 Bending test

The tube shall withstand cold bending through 180° over a rod of the same diameter as the outside diameter of the tube, without showing other than superficial outside ruptures.

5.5 Cold upsetting of tubes

This test shall be carried out on tubes of outside diameter 15 mm and below.

A length of tube equal to twice the outside diameter (2D) shall be capable of being compressed to a length D without showing cracks of depths exceeding 0,13 mm.

This test shall be made between two plane and parallel plates in a suitable fixture.

5.6 Surface quality test

A visual check shall be made to ensure that tubes satisfy the requirements in 4.3.

Table 4 – Mechanical properties¹⁾

Code	Minimum tensile strength R_m N/mm ²	Minimum upper yield stress R_{eH} N/mm ²	Minimum percentage elongation A_5 %	Maximum hardness HV
1	310	205	30	115
2	360	220	23	150
3	490	355	22	194

1) The mechanical properties apply when the tube is tested in accordance with ISO 6892.

5.6.1 If mutually agreed between the supplier and purchaser, the visual inspection may be replaced by a non-destructive test procedure.

5.6.2 If a proof of a specified defect depth in the bore is required, an inspection by attributes, with an agreed AQL (Acceptable Quality Level) shall be set when ordering; the test shall be made on metallographic cross-sections of the tube with the minimum magnification specified in table 2.

5.6.3 Surface coatings on tubes with plated or otherwise treated surfaces shall satisfy tests on these coatings when required. Such tests shall be agreed between supplier and purchaser.

5.7 Inside pressure test

Tubes shall be capable of withstanding appropriate inside pressures as calculated from the following formulae without permanent internal deformation. This ability shall be confirmed by a hydraulic test. Another non-destructive test, such as electronic testing, may be conducted if agreed between supplier and purchaser.

The theoretical maximum test pressure, p_{max} , is given, in kilopascals, by the product of the stress coefficient and the upper yield stress, R_{eH} :

$$p_{max} = 10^3 \frac{K^2 - 1}{\sqrt{1 + 3K^4}} \times R_{eH}$$

where $K = \frac{D}{d}$

in which

D is the outside diameter, in millimetres;

d is the inside diameter, in millimetres.

5.8 Retest

If, after testing according to 5.3, the selected tube fails, two other tubes shall be taken from the same lot to repeat the test. The same procedure applies to the test in 5.5. Each of the tubes taken shall meet the test requirements. If any tube fails the test requirements, the whole lot is considered as rejected.

The supplier may submit a rejected lot for acceptance again in an improved condition, e.g. by repeating the heat treatment.

If, in this case, the test results of 5.3 and 5.5 do not fulfill the requirements, the whole lot shall be rejected.

5.9 Test certificate

A test certificate if required [see clause 6i)] shall be issued for each shipment, confirming that the tubes supplied meet the specifications of this part of ISO 8535. For proof, the records of the continuous production inspection concerning the following tests can be used:

- a) dimensions according to 5.2;
- b) mechanical properties according to 5.3;
- c) cold upsetting according to 5.5;
- d) visual inspection according to 5.6.1;
- e) metallographic test according to 5.6.2;
- f) inside pressure test according to 5.7.

Additional test certificates may be agreed upon between supplier and purchaser.

6 Designation

A steel tube that meets the requirements of this part of ISO 8535 shall be designated as follows, in the order given:

- a) the word "tube";
- b) reference to this part of ISO 8535;
- c) type: a seamless cold-drawn single-wall steel tube is indicated by the letter "S";
- d) size: the second and third elements identify the inside and outside diameters respectively of the tube, in millimetres;
- e) class is determined by the bore tolerance [see 3.1 a)];
- f) the fifth character identifies the mechanical properties of the tube in accordance with table 4;
- g) the sixth character identifies the bore grade of the tube in accordance with table 2;
- h) the seventh character identifies the treatment of the outside surface of the tube (see table 3);
- i) at the end of the designation, the letter "Z" may be added to indicate that a certificate from the tube manufacturer is required for confirmation of compliance with this part of ISO 8535 and additional delivery requirements, if any (see ISO 404).

EXAMPLE

A tube conforming to this part of ISO 8535 shall be designated as shown:

