

HM b] bY'f]gVY!'-býHUUWY'; fU] b]g]a Vc`]nUUj lca Uhg\_c`i dfUj`UbY]b'bUXncf

Technical drawings -- Installations -- Graphical symbols for automatic control

Dessins techniques -- Installations -- Symboles graphiques pour systèmes de commande automatiques

(standards.iteh.ai)

Ta slovenski standard je istoveten z: **ISO/TR 8545:1984**

<https://standards.iteh.ai/catalog/standards/sist/be923999-38fc-4ade-a29f-88cd122990ef/sist-iso-tr-8545-1995>

**ICS:**

- |           |   |  |
|-----------|---|--|
| 01.080.30 | Ö æã } ã ã à [  á æÁ ] [  æ  Á<br> ã àæãæ  æ ãæ æ  æ<br>: ^ {  b çãã  Á d [   ã ç Á<br>*  æ à ^ } ã ç Á   Á Á • d ^ : } ã<br>¢ @ ã } ã   [ ã ç   ã } ã<br>à [ \ { ^ } æãã | Graphical symbols for use on mechanical engineering and construction drawings, diagrams, plans, maps and in relevant technical product documentation |
| 01.100.30 | Ö æ à ^ } ã æ  ã  | Construction drawings  |

**SIST ISO/TR 8545:1995**

**en**

**iTeh STANDARD PREVIEW**  
**(standards.iteh.ai)**

[SIST ISO/TR 8545:1995](#)

<https://standards.iteh.ai/catalog/standards/sist/be923999-38fc-4ade-a29f-88cd122990ef/sist-iso-tr-8545-1995>



Published 1984-06-01

INTERNATIONAL ORGANIZATION FOR STANDARDIZATION • МЕЖДУНАРОДНАЯ ОРГАНИЗАЦИЯ ПО СТАНДАРТИЗАЦИИ • ORGANISATION INTERNATIONALE DE NORMALISATION

# Technical drawings — Installations — Graphical symbols for automatic control

*Dessins techniques — Installations — Symboles graphiques pour systèmes de commande automatiques*

Draft International Standard ISO/DIS 4067/3 was submitted in 1979 to the combined voting procedure, but it did not meet the minimum voting requirements necessary for its publication as an International Standard.

In 1982 the members of ISO/TC 10 agreed by majority vote to publish ISO/DIS 4067/3 as Technical Report (type 1) ISO/TR 8545, until such time as coordination problems within ISO/TC 10 have been solved.

## 1 Scope and field of application

This Technical Report establishes a series of graphical symbols for equipment and functional connections, for use on drawings and diagrams for the installation of automatic control systems.

The majority of the symbols are shown in conjunction with their corresponding functional connection lines.

The size of the symbols shall be related to the scale of the drawing.

If a more detailed representation is required, the symbols can be combined with designations indicated on the drawing or in a separate schedule.

For representation on flow sheets for more advanced process systems, ISO 3511/1 is recommended.

## 2 References

ISO 128, *Technical drawings — General principles of presentation*.

ISO 1219, *Fluid power systems and components — Graphic symbols*.

ISO 3511, *Process measurement control functions and instrumentation — Symbolic representation —*

*Part 1 : Basic requirements.*

*Part 2 : Extension of basic requirements.<sup>1)</sup>*

*Part 3 : Detailed symbols for instrument interconnection diagrams.<sup>1)</sup>*

<sup>1)</sup> At present at the stage of draft.

UDC 744.43 : 681.5 : 003.62

Ref. No. : ISO/TR 8545-1984 (E)











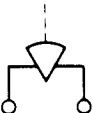

**Descriptors:** drawings, technical drawings, buildings, automatic systems, automatic control, graphic methods, symbols, graphical symbols.

© International Organization for Standardization, 1984 •

Printed in Switzerland





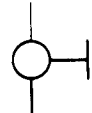



Price based on 6 pages

## 3 Symbols for control and regulating systems

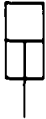
No.	Description	Basic symbol	Application of symbol
3.1	Measuring point		
3.2	Two measuring points		
3.3	Transmitter		
3.4	Transmitter with external measuring point		
3.5	Transmitter with internal measuring point		
3.6	Transmitter for measuring differences		
3.7	General control unit	 or 	
3.8	Manual setting device		
3.9	Actuator		
3.10	Actuator maintaining position on failure of its energy supply		
3.11	Actuator closing on failure of its energy supply		
3.12	Actuator opening on failure of its energy supply		
3.13	Actuator, automatic		
3.14	Actuator, automatic with manual setting device		

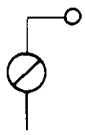
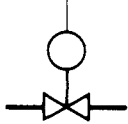
iTeh STANDARD PREVIEW  
(standards.iteh.ai)

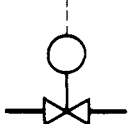

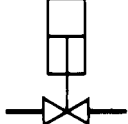
SIST ISO/TR 8545:1995  
<https://standards.iteh.ai/catalog/standards/sist/be923999-38fd-4ade-a29f-88cd122990ef/sist-iso-tr-8545-1995>

No.	Description	Basic symbol	Application of symbol
3.15	Actuator, automatic with electrical power unit		
3.16	Actuator, automatic with diaphragm power unit		
3.17	Actuator, automatic with piston power unit		
3.18	Actuator, automatic with solenoid coil		
3.19	Actuator with sensing element		
3.20	Actuator, self-contained, with external measuring point		
3.21	Valve with actuator		
3.22	Hand-operated valve		
3.23	Automatic control valve with electrical power unit		
3.24	Automatic control valve with diaphragm power unit		
3.25	Automatic control valve with piston power unit		

iteh STANDARD PREVIEW  
(standards.iteh.ai)

SIST ISO/TR 8545:1995  
<https://standards.iteh.ai/catalog/standards/sist/be923999-38fc-4ade-a29f-88cd122990ef/sist-iso-tr-8545-1995>

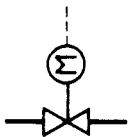
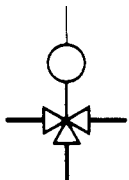
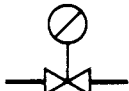
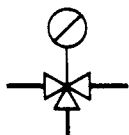
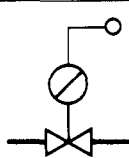
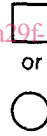
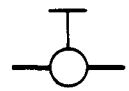
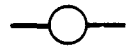

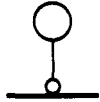
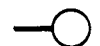

## ISO/TR 8545-1984 (E)

No.	Description	Basic symbol	Application of symbol
3.26	Automatic control valve with solenoid coil		
3.27	Automatic control valve, three-way		
3.28	Self-contained control valve with internal sensing element, for example : thermostatic valve level controller		
3.29	Self-contained control valve with internal sensing element, three-way, for example : thermostatic mixing valve		
3.30	Self-contained control valve with external sensing element, for example : pressure controller or thermostatic valve		
3.31	General auxiliary unit	 or	
3.32	Auxiliary unit with manual setting device		
3.33	Signal converter		
3.34	Restriction unit		
3.35	Pressure source		

## 4 Symbols for measuring instruments

No.	Description	Basic symbol	Application of symbol
4.1	Measuring instrument		
4.2	Measuring instrument with external measuring point		
4.3	Measuring instrument with internal measuring point		

## 5 Symbols for process lines and functional connections

No.	Description	Basic symbol	Symbol	Relative thickness
5.1	Process lines, primary			3
5.2	Process lines, secondary			2
5.3	Functional connections			1
5.4	Pneumatic and hydraulic functional connections			1
5.5	Electrical functional connections			1

## 6 Symbols for break- and enclosing lines

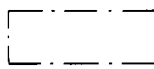
No.	Description	Basic symbol	Symbol	Relative thickness
6.1	Break-lines			1
6.2	Enclosing lines for a group of units			1

## 7 Examples of the use of symbols

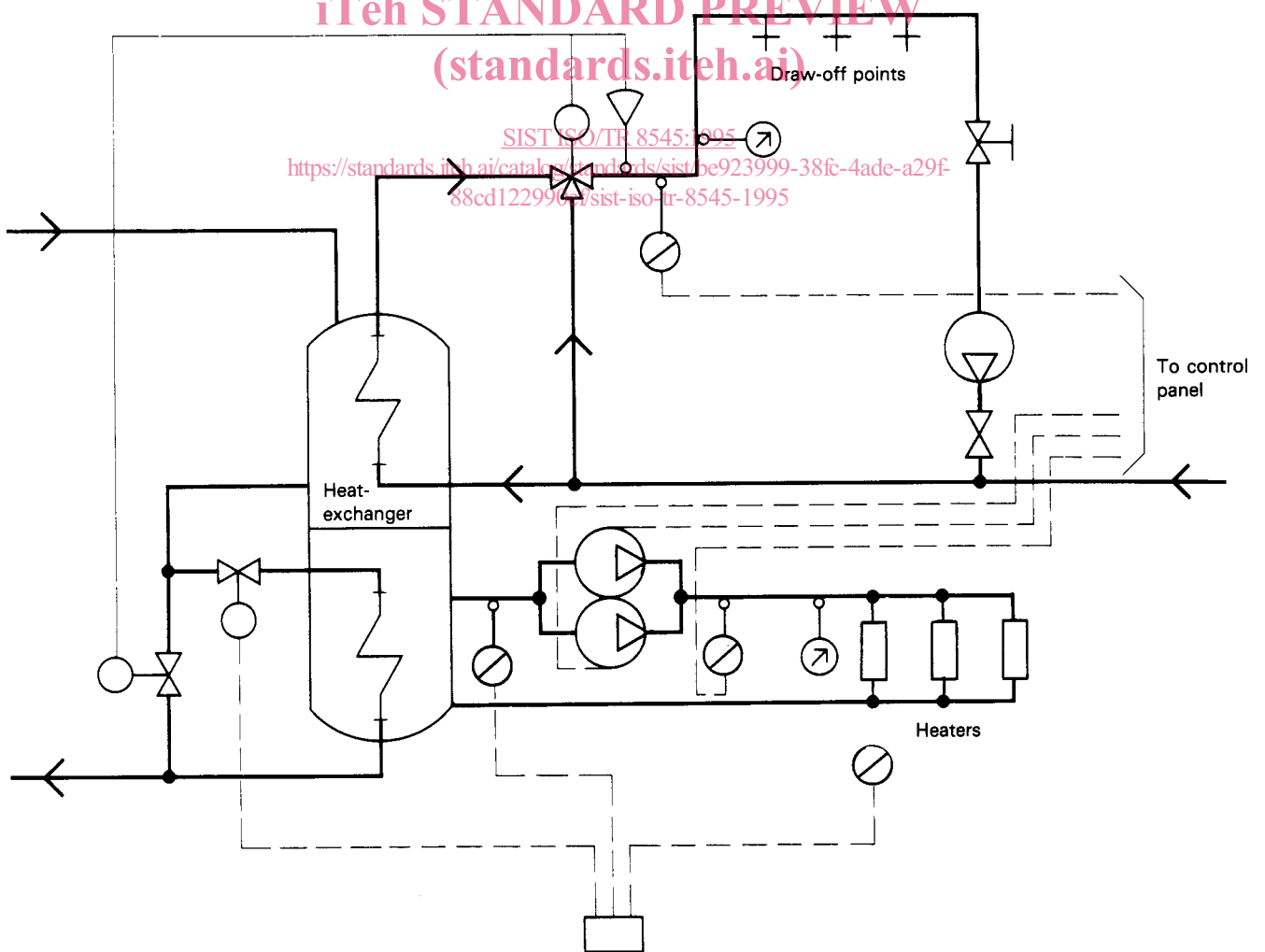

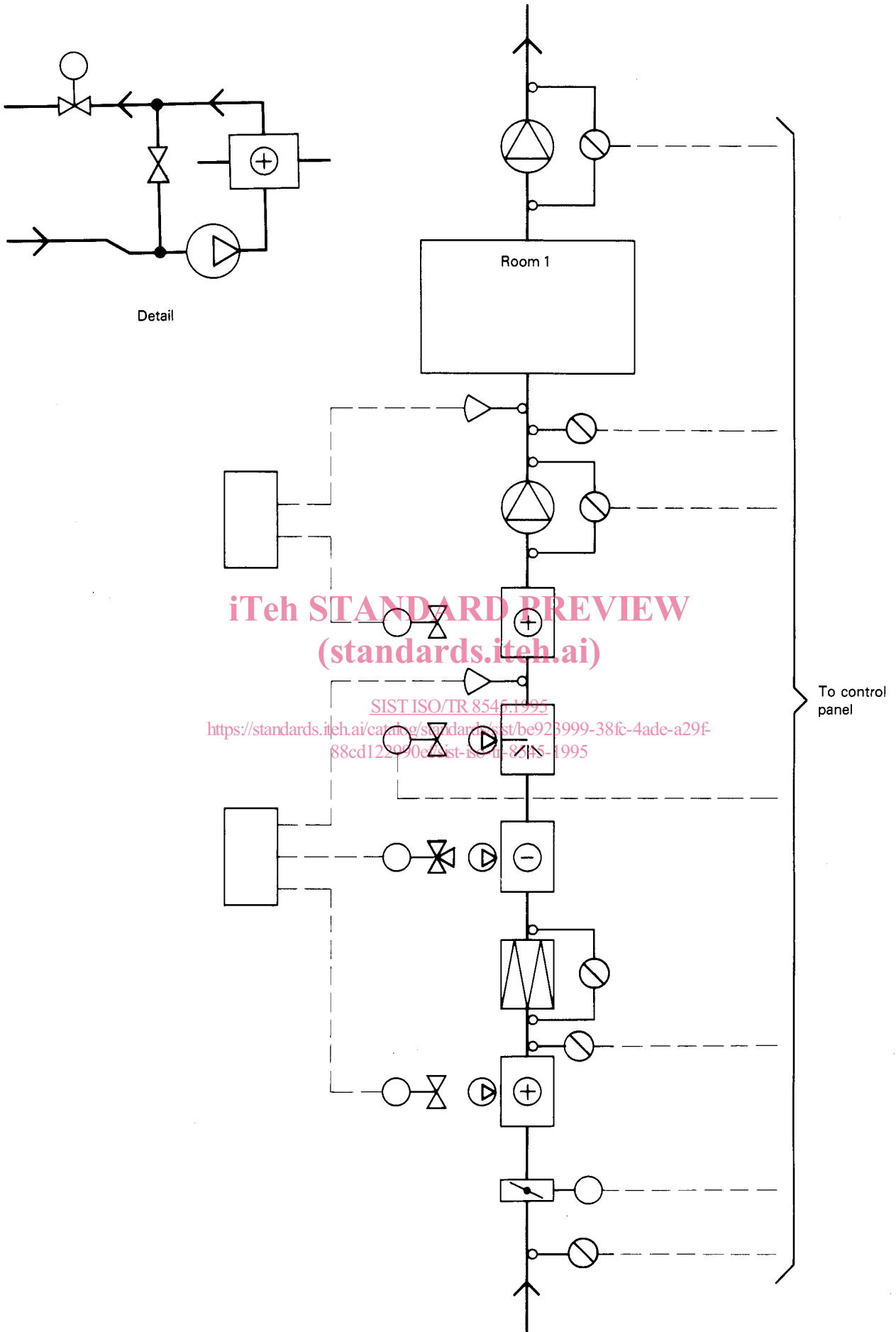

Example 2