

INTERNATIONAL STANDARD

**ISO
8570**

First edition
1991-08-15

Plastics — Film and sheeting — Determination of cold-crack temperature

iTeh STANDARD PREVIEW
*Plastiques — Film et feuille — Détermination de la température de
fragilité à froid*
(standards.iteh.ai)

ISO 8570:1991

<https://standards.iteh.ai/catalog/standards/sist/0165967b-f603-4808-8259-66c48a3808c6/iso-8570-1991>



Reference number
ISO 8570:1991(E)

Foreword

ISO (the International Organization for Standardization) is a worldwide federation of national standards bodies (ISO member bodies). The work of preparing International Standards is normally carried out through ISO technical committees. Each member body interested in a subject for which a technical committee has been established has the right to be represented on that committee. International organizations, governmental and non-governmental, in liaison with ISO, also take part in the work. ISO collaborates closely with the International Electrotechnical Commission (IEC) on all matters of electrotechnical standardization.

Draft International Standards adopted by the technical committees are circulated to the member bodies for voting. Publication as an International Standard requires approval by at least 75% of the member bodies casting a vote.

International Standard ISO 8570 was prepared by Technical Committee ISO/TC 61, *Plastics*, Sub-Committee SC 11, *Products*.

[ISO 8570:1991](#)

<https://standards.iteh.ai/catalog/standards/sist/0165967b-f603-4808-8259-66c48a3808c6/iso-8570-1991>

© ISO 1991

All rights reserved. No part of this publication may be reproduced or utilized in any form or by any means, electronic or mechanical, including photocopying and microfilm, without permission in writing from the publisher.

International Organization for Standardization

Case Postale 56 • CH-1211 Genève 20 • Switzerland

Printed in Switzerland

Plastics — Film and sheeting — Determination of cold-crack temperature

1 Scope

This International Standard specifies a method for assessing the brittleness of plastic film and sheeting at low temperature.

The assessment is given in the form of a conventional cold-crack temperature which serves as a guideline for comparing the low-temperature behaviour of plastic film and sheeting.

This method characterizes a finished product of given thickness and texture, but not its raw-material composition. Data derived using this International Standard cannot be transposed without limitation to any other shapes or conditions of application.

2 Normative references

The following standards contain provisions which, through reference in this text, constitute provisions of this International Standard. At the time of publication, the editions indicated were valid. All standards are subject to revision, and parties to agreements based on this International Standard are encouraged to investigate the possibility of applying the most recent editions of the standards indicated below. Members of IEC and ISO maintain registers of currently valid International Standards.

ISO 291:1977, *Plastics — Standard atmospheres for conditioning and testing*.

ISO 4593:1979, *Plastics — Film and sheeting — Determination of thickness by mechanical scanning*.

3 Definition

For the purposes of this International Standard, the following definition applies.

3.1 cold-crack temperature: The temperature at which 50 % of test specimens break or exhibit

damage when tested by the method specified in this International Standard.

4 Principle

Specimens bowed in the shape of a loop are placed in a cooling chamber and subjected to sudden folding under the impact of a free-falling mass.

The test is repeated at temperatures scaled in increments of 5 °C, commencing when no specimen breaks or is damaged and ending when all specimens are broken or damaged.

5 Apparatus

The following description is an example of a typical test apparatus design (see figure 1). Other designs can be used provided that the physical principles are equivalent. Figure 2 shows another appropriate design.

5.1 Impact device, comprising the following elements:

5.1.1 Specimen holder, permitting the fastening of one or more specimens on a platen by means of clamps (e.g. leaf springs) to clench each specimen along its entire width (15 mm) and to secure 10 mm of each end of the loop (see figure 1) so that the length of the loop section subjected to folding is 40 mm.

The platen may be equipped with a mechanism (revolving type) that allows each specimen to be placed successively in the test position under the guide tube (5.1.4) which guides the impact mass (5.1.3).

Another possibility is to equip the test apparatus with guide tubes each provided with its own impact mass. The guide tubes may be arranged in a line or in a circle, depending on the space available in the cooling chamber (5.2).

5.1.2 Rigid anvil, connected to, or part of, the specimen holder (5.1.1), and on which the specimen is brought into the test position.

5.1.3 Two impact masses, one 200 g, the other 500 g, consisting of metal cylinders with a diameter of not less than 18 mm and not more than 29 mm, the edge of the lower face being slightly rounded.

5.1.4 Guide tube, to guide the impact mass (5.1.3), equipped at the upper end with a mechanism to release the mass (solenoid or mechanical trigger).

This tube, approximately 250 mm long and with a diameter 1 mm larger than that of the impact mass, shall be placed vertically above the specimen test position and shall be mounted so that the drop

height, i.e. the distance between the base of the impact mass and the anvil, is $200 \text{ mm} \pm 2 \text{ mm}$.

5.1.5 Holding device, to align the platen and the guide tube (5.1.4) in such a position that the centre of the impact mass coincides with the edge of the flattened loop (20 mm from the clamp).

5.2 Cooling chamber, to house the impact device (5.1), allowing the temperature to be lowered in steps of $5 \text{ }^\circ\text{C}$, and able to maintain a temperature constant to within $\pm 1 \text{ }^\circ\text{C}$.

5.3 Thermometer, graduated in $0,5 \text{ }^\circ\text{C}$, or **thermocouple**, with an accuracy of $0,5 \text{ }^\circ\text{C}$, placed in the cooling chamber (5.2) in the proximity of the specimens.

Dimensions in millimetres

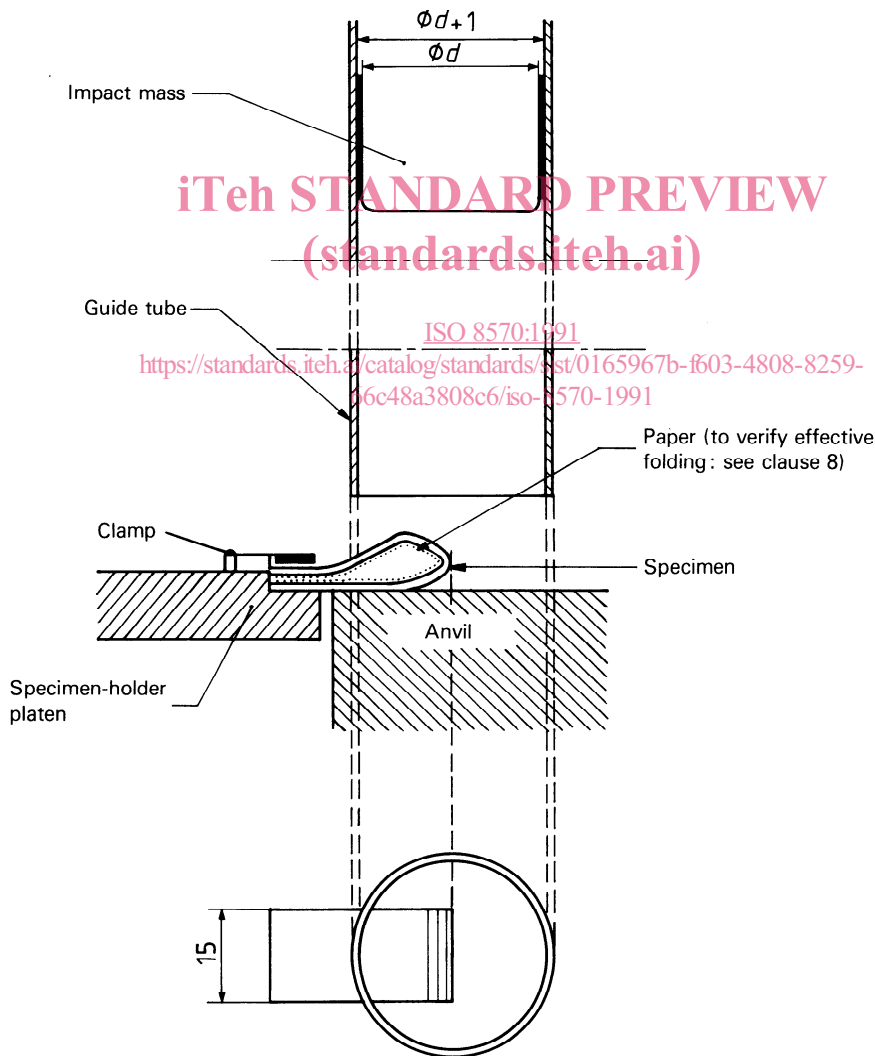

Figure 1 — Typical impact device for determination of cold-crack temperature

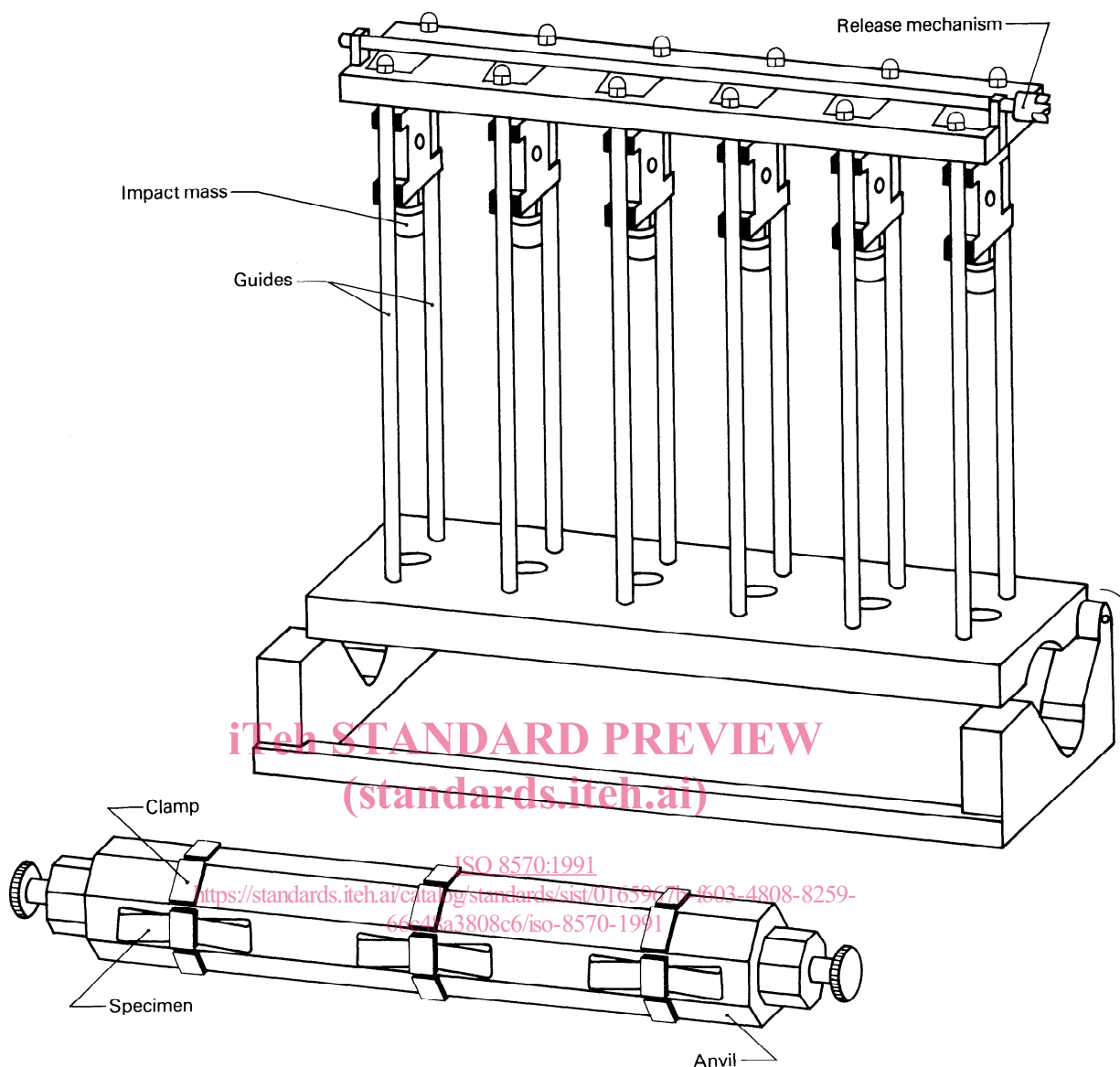

Figure 2 — Alternative design of cold-crack test apparatus

6 Specimens

6.1 Shape and dimensions

The specimens shall consist of strips measuring 60 mm × 15 mm. Their edges shall be free from cuts, scratches and other imperfections.

The thickness shall be measured in accordance with ISO 4593.

6.2 Taking specimens

For each temperature, 10 specimens shall be taken with their long axis (60 mm) parallel to the machine (i.e. longitudinal) direction, and 10 specimens with their long axis parallel to the transverse direction.

All specimens shall be taken at a distance of at least 150 mm from the edge and more than 1 m from the beginning or the end of the roll.

7 Conditioning of specimens

Bow the specimens in the form of loops and mount them in the specimen holder (5.1.1). If the film or sheeting is printed or textured on one side, this side shall be on the outside of the loop.

Condition the mounted specimens for a minimum of 3 h in one of the atmospheres specified in ISO 291.

8 Selection of impact mass

If there is no prior agreement upon the value of the impact mass, start the test with the 200 g mass,

provided that this mass is sufficient to fold the specimen effectively. If this is not the case, use the 500 g mass.

The following criterion may be used to verify effective folding. Bend a strip of paper (about 70 g/m²), of the same dimensions as the specimen, into a loop and place it inside the loop of a specimen. Test the combined plastic/paper specimen with the 200 g mass by the procedure given in clause 9, using a test temperature slightly higher than the cold-crack temperature in order to prevent the specimen breaking. Inspect the paper strip. A sharp crease at the tip of the loop indicates effective folding.

9 Procedure

9.1 Verify the alignment of the guide tube (5.1.4) with respect to the position of the specimen on the platen.

9.2 Place the impact device containing the mounted specimens in the cooling chamber (5.2). When the impact device has reached equilibrium at the test temperature (approximately 15 min), position the specimen (in the case of a revolving-type device, the first specimen) below the guide tube. Release the impact mass (5.1.3) then reset it to its initial position. Repeat the operation for the other specimens, if any.

Take the platen out of the cooling chamber, remove the specimens and inspect them.

A specimen is deemed to be damaged or broken if any trace of breaking is visible to the naked eye. This trace can be a point or a line, while total rupture may occur, with or without splintering (see figure 3). A whitish line at the fold may occur with certain types of pigmented or unpigmented material, but this is not considered as a failure.

9.3 If no specimen is damaged or broken, lower the temperature of the cooling chamber by 5 °C and repeat the test as specified in 9.1 and 9.2 with fresh specimens. If all the specimens are still unaffected, repeat the test at temperatures decreasing by 5 °C, with a new set of specimens each time. Record the number of specimens unbroken and broken or damaged at each temperature, applying the test criterion given in 9.2.

Continue the test until a temperature is reached at which all specimens are broken or damaged.

9.4 If, at the start of the test, one or more specimens is broken or damaged, repeat the test at temperatures increasing in increments of 5 °C until no specimen is damaged. From this point, follow the procedure described in 9.3.

ISO 8570:1991

<https://standards.iteh.ai/catalog/standards/sist/0165967b-f603-4808-8259-66c48a3808c6/iso-8570-1991>



No sign of crack		
Broken or damaged	Trace of crack: points or dashes	
	Trace of crack: line	
	Total rupture: no fragments	
	iTeh STANDARD PREVIEW (standards.iteh.ai)	
	Total rupture: with fragments	

Figure 3 — Rating of cold-crack specimens

10 Expression of results

10.1 Graphical method

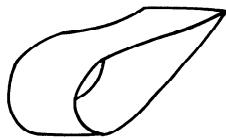
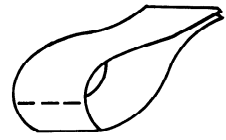
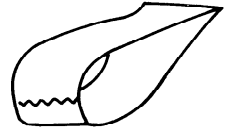
Plot the percentage failure at each temperature against the test temperature on arithmetic-probability paper and draw the best straight line through the results. Read the cold-crack temperature from the graph (the point where this line intersects the 50 % probability line).

10.2 Calculation method

The cold-crack temperature t_B , in degrees Celsius, can be calculated as follows:

$$t_B = t_K + \Delta t \left(\frac{\sum n}{n_0} - 0,5 \right)$$

where

t_K is the highest test temperature, in degrees Celsius, at which all specimens (normally 10) were broken or damaged;

Δt is the difference, in degrees Celsius, between two consecutive test temperatures (normally 5 °C);

$\sum n$ is the total number of all broken or damaged specimens (from the temperature t_K to the temperature at which no specimen is broken or damaged);

n_0 is the number of specimens tested at each temperature (normally 10).

11 Test report

The test report shall include the following particulars:

a) a reference to this International Standard;

- b) all details necessary for the complete identification of the material tested, including thickness, date of manufacture and type of surface (printed, textured);
- c) the cold-crack temperature, in degrees Celsius, with the impact mass in brackets, e.g. (200): – 13 °C, for both the machine (longitudinal) and the transverse directions;
- d) the number of specimens tested at each temperature;
- e) the type of failure (crack, rupture with fragments, rupture without fragments);
- f) any deviations from the procedure specified.

iTeh STANDARD PREVIEW
(standards.iteh.ai)

[ISO 8570:1991](#)

<https://standards.iteh.ai/catalog/standards/sist/0165967b-f603-4808-8259-66c48a3808c6/iso-8570-1991>

iTeh STANDARD PREVIEW
(standards.iteh.ai)

This page intentionally left blank

[ISO 8570:1991](#)

<https://standards.iteh.ai/catalog/standards/sist/0165967b-f603-4808-8259-66c48a3808c6/iso-8570-1991>