**Mechanical vibration — Evaluation
of machine vibration by measurements
on non-rotating parts —**

Part 5:

**Machine sets in hydraulic power generating
and pumping plants**

iTeh STANDARDS PREVIEW
(standards.itih.ai)

*Vibrations mécaniques — Évaluation des vibrations des machines par
mesurages sur les parties non tournantes —*

*Partie 5: Groupes générateurs de puissance et installations de pompage
hydrauliques*



PDF disclaimer

This PDF file may contain embedded typefaces. In accordance with Adobe's licensing policy, this file may be printed or viewed but shall not be edited unless the typefaces which are embedded are licensed to and installed on the computer performing the editing. In downloading this file, parties accept therein the responsibility of not infringing Adobe's licensing policy. The ISO Central Secretariat accepts no liability in this area.

Adobe is a trademark of Adobe Systems Incorporated.

Details of the software products used to create this PDF file can be found in the General Info relative to the file; the PDF-creation parameters were optimized for printing. Every care has been taken to ensure that the file is suitable for use by ISO member bodies. In the unlikely event that a problem relating to it is found, please inform the Central Secretariat at the address given below.

iTeh STANDARD PREVIEW
(standards.iteh.ai)

ISO 10816-5:2000

<https://standards.iteh.ai/catalog/standards/sist/b2ccfd7c-84b8-4e86-a8bc-f088a8fa44be/iso-10816-5-2000>

© ISO 2000

All rights reserved. Unless otherwise specified, no part of this publication may be reproduced or utilized in any form or by any means, electronic or mechanical, including photocopying and microfilm, without permission in writing from either ISO at the address below or ISO's member body in the country of the requester.

ISO copyright office
Case postale 56 • CH-1211 Geneva 20
Tel. + 41 22 749 01 11
Fax + 41 22 734 10 79
E-mail copyright@iso.ch
Web www.iso.ch

Printed in Switzerland

Contents

	Page
Foreword.....	iv
Introduction.....	v
1 Scope	1
2 Normative references	2
3 Machine arrangements.....	2
4 Measurement procedures and conditions	7
4.1 General.....	7
4.2 Measurement type	8
4.3 Measurement locations and directions	8
4.4 Measurement equipment	9
4.5 Operational conditions.....	10
5 Evaluation.....	10
5.1 General.....	10
5.2 Criterion I: Vibration magnitude.....	10
5.3 Evaluation zone limits.....	10
5.3.1 Turbine operating conditions.....	10
5.3.2 Pump operating conditions	11
5.3.3 Special operating conditions.....	11
5.3.4 Axial vibration	11
5.4 Criterion II: Change in vibration magnitude.....	12
5.5 Operational limits.....	12
5.5.1 General.....	12
5.5.2 Setting of ALARMS.....	12
5.5.3 Setting of TRIPS.....	13
5.5.4 Special operating conditions.....	13
5.6 Supplementary procedures/criteria	13
5.7 Evaluation based on vibration vector information.....	13
Annex A (normative) Evaluation zone boundaries	14
Annex B (informative) Special features of bearing housing vibration of hydraulic machine sets	16
Annex C (informative) Analysis procedure and applied regression technique.....	18
Bibliography	19

Foreword

ISO (the International Organization for Standardization) is a worldwide federation of national standards bodies (ISO member bodies). The work of preparing International Standards is normally carried out through ISO technical committees. Each member body interested in a subject for which a technical committee has been established has the right to be represented on that committee. International organizations, governmental and non-governmental, in liaison with ISO, also take part in the work. ISO collaborates closely with the International Electrotechnical Commission (IEC) on all matters of electrotechnical standardization.

International Standards are drafted in accordance with the rules given in the ISO/IEC Directives, Part 3.

Draft International Standards adopted by the technical committees are circulated to the member bodies for voting. Publication as an International Standard requires approval by at least 75 % of the member bodies casting a vote.

Attention is drawn to the possibility that some of the elements of this part of ISO 10816 may be the subject of patent rights. ISO shall not be held responsible for identifying any or all such patent rights.

International Standard ISO 10816-5 was prepared by Technical Committee ISO/TC 108, *Mechanical vibration and shock*, Subcommittee SC 2, *Measurement and evaluation of mechanical vibration and shock as applied to machines, vehicles and structures*.

ISO 10816 consists of the following parts, under the general title *Mechanical vibration — Evaluation of machine vibration by measurements on non-rotating parts*:

- Part 1: *General guidelines*
- Part 2: *Large land-based steam turbine generator sets in excess of 50 MW*
- Part 3: *Industrial machines with nominal power above 15 kW and nominal speeds between 120 r/min and 15 000 r/min when measured in situ*
- Part 4: *Gas turbine driven sets excluding aircraft derivatives*
- Part 5: *Machine sets in hydraulic power generating and pumping plants*
- Part 6: *Reciprocating machines with power ratings above 100 kW*

Annex A forms a normative part of this part of ISO 10816. Annexes B and C are for information only.

Introduction

ISO 10816-1 is the basic document which describes the general requirements for evaluating vibration of various machine types when the vibration measurements are made on non-rotating parts. This part of ISO 10816 provides specific guidance for assessing the severity of vibration measured at the bearings, bearing pedestals or bearing housings of machine sets in hydraulic power generating and pumping plants when measurements are made *in situ*.

Two criteria are provided for assessing the machine vibration. One criterion considers the magnitude of observed vibration; the second considers changes in the magnitudes. It must be recognized, however, that these two criteria do not form the only basis for judging the severity of vibration. For most machine types it is also common to judge the vibration based on measurements taken on the rotating shaft. Shaft vibration measurement requirements and criteria are addressed in separate documents, ISO 7919-1 and ISO 7919-5.

iTeh STANDARD PREVIEW (standards.iteh.ai)

[ISO 10816-5:2000](https://standards.iteh.ai/catalog/standards/sist/b2ccfd7c-84b8-4e86-a8bc-f088a8fa44be/iso-10816-5-2000)

<https://standards.iteh.ai/catalog/standards/sist/b2ccfd7c-84b8-4e86-a8bc-f088a8fa44be/iso-10816-5-2000>

iTeh STANDARD PREVIEW
(standards.iteh.ai)

ISO 10816-5:2000

<https://standards.iteh.ai/catalog/standards/sist/b2ccfd7c-84b8-4e86-a8bc-f088a8fa44be/iso-10816-5-2000>

Mechanical vibration — Evaluation of machine vibration by measurements on non-rotating parts —

Part 5:

Machine sets in hydraulic power generating and pumping plants

1 Scope

This part of ISO 10816 gives guidelines for applying bearing housing vibration evaluation criteria measured under normal operating conditions at the bearings, bearing pedestals or bearing housings of the main machine sets in hydraulic power generating and pumping plants. These guidelines are presented in terms of both steady-state running vibration and any amplitude changes which may occur in these steady values. The numerical values specified are not intended to serve as the only basis for vibration evaluation, since, in general, the vibratory condition of a machine is assessed by consideration of both the bearing housing vibration and the associated shaft vibration (see introduction of ISO 10816-1 and ISO 7919-1).

This part of ISO 10816 is applicable to machine sets in hydraulic power generating and pumping plants where the hydraulic machines have speeds from 60 r/min to 1800 r/min, shell or shoe type sleeve bearings and a main engine power of 1 MW and more. The position of the shaft line may be vertical, horizontal or at an arbitrary angle between these two directions.

Machine sets covered by this part of ISO 10816 may be combined from

- hydraulic turbines and generators,
- pumps and electrical machines operating as motors, or
- pump-turbines and motor-generators.

Auxiliary equipment (e.g. starting turbines or exciters lying in the shaft line) is included. Evaluation criteria are at present only given for the main bearings of the machine set.

This part of ISO 10816 is applicable also to single turbines or pumps connected to generators or electrical motors over gears or/and radially flexible couplings. However, electrical machines of this type should in principal be evaluated according to the criteria specified in ISO 10816-3.

This part of ISO 10816 is not applicable to the following:

- pumps in thermal power plants or industrial installations (for these machines, see ISO 10816-3);
- hydraulic machines or machine sets having rolling element bearings.

Consistent with clause 1 of ISO 10816-1:1995, bearing housing vibration of machine sets in hydraulic power generating and pumping plants may be determined with regard to following tasks:

- task A: monitoring changes in vibrational behaviour;
- task B: prevention of excessive kinetic load.

The criteria are applicable mainly for the vibration produced by the machine set itself. Special considerations should be made when necessary for vibration transmitted to the machine set from external sources.

2 Normative references

The following normative documents contain provisions which, through reference in this text, constitute provisions of this part of ISO 10816. For dated references, subsequent amendments to, or revisions of, any of these publications do not apply. However, parties to agreements based on this part of ISO 10816 are encouraged to investigate the possibility of applying the most recent editions of the normative documents indicated below. For undated references, the latest edition of the normative document referred to applies. Members of ISO and IEC maintain registers of currently valid International Standards.

ISO 10816-1:1995, *Mechanical vibration — Evaluation of machine vibration by measurements on non-rotating parts — Part 1: General guidelines*.

IEC 60994, *Guide for field measurement of vibrations and pulsations in hydraulic machines (turbines, storage pumps and pump-turbines)*.

3 Machine arrangements

Significant differences in design and arrangement of hydraulic machine sets require a separation into four principal groups with regard to the radial bearing stiffness, as follows.

Group 1: Horizontal machine sets with pedestal or end-shield bearings mounted on a rigid foundation, usually with operational speeds of above 300 r/min.

Group 2: Horizontal machine sets with bearing housings which are only braced against the casing of the hydraulic machine, usually with operational speeds of less than 300 r/min.

Group 3: Vertical machine sets with bearing housings which are all braced against the foundation, usually with operational speeds of between 60 r/min and 1 800 r/min.

Group 4: Vertical machine sets with lower bearing housings braced against the foundation and upper bearing housings braced against the generator stator only, usually with operational speeds of between 60 r/min and 1 000 r/min.

NOTE Umbrella-type machines belong to Group 4.

Figures 1 to 4 show examples for each group.

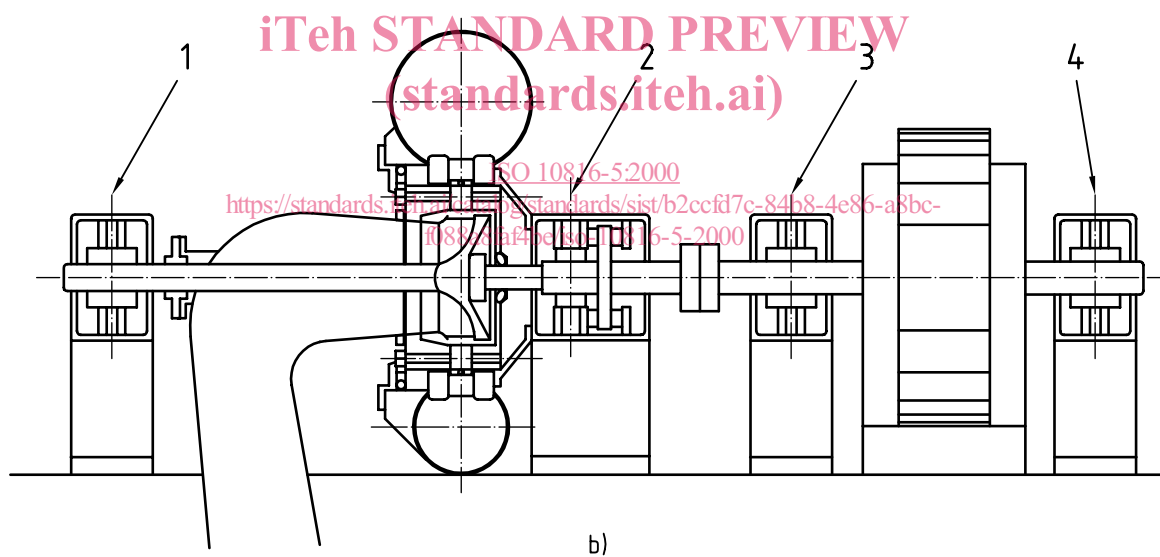
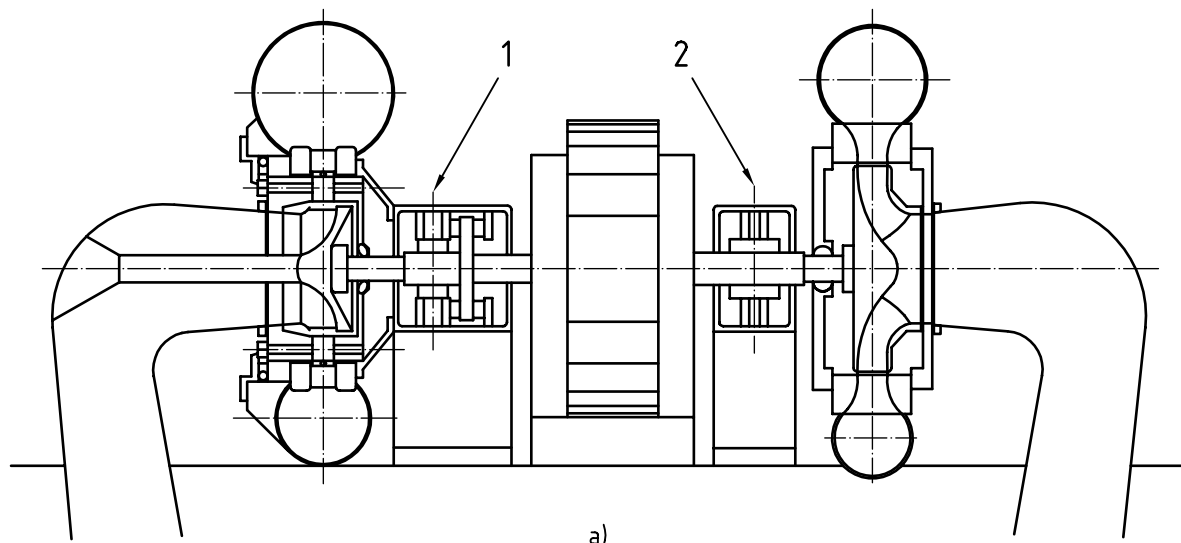

NOTE The numbers indicate measurement locations.

Figure 1 — Measurement locations for Group 1 machine sets with horizontal shaft and pedestal or end-shield bearings mounted on rigid foundation, usually with operational speeds of above 300 r/min

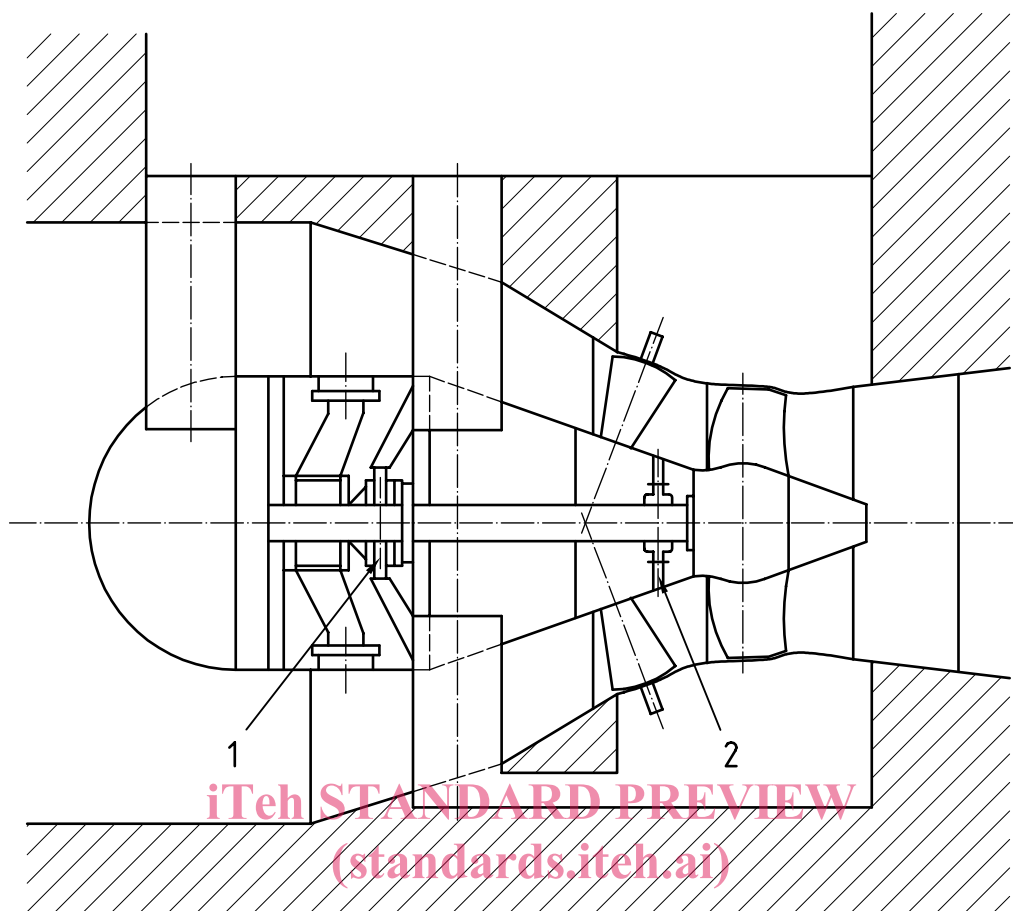

NOTE The numbers indicate measurement locations.
<https://standards.iteh.ai/catalog/standards/sist/b2ccfd7c-84b8-4e86-a8bc-f088a8fa44be/iso-10816-5-2000>

Figure 2 — Measurement locations for a Group 2 machine set with horizontal shaft and bearing housings which are only braced against the casing of the hydraulic machine, usually with operational speeds of less than 300 r/min

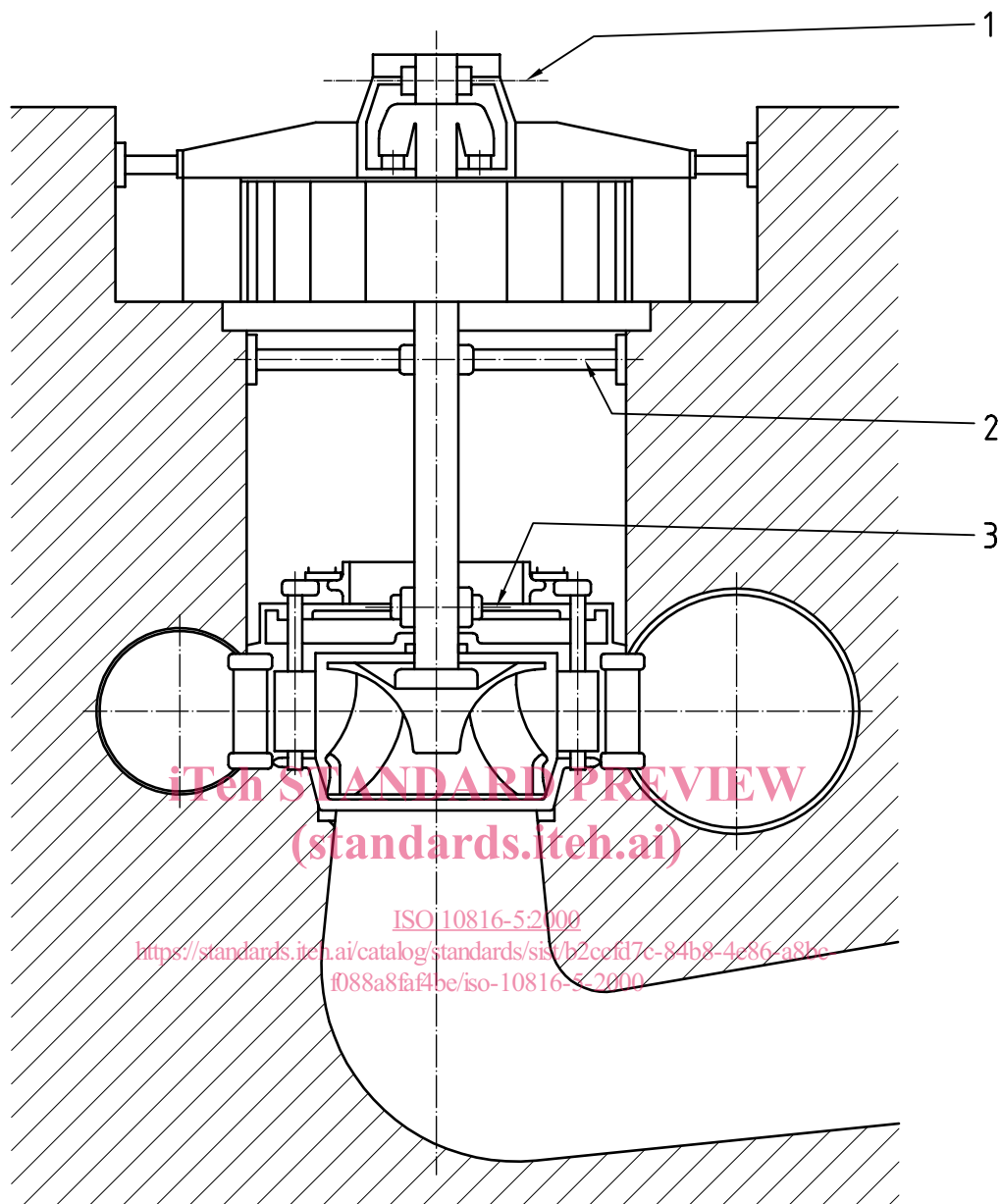

NOTE The numbers indicate measurement locations.

Figure 3 — Measurement locations for a Group 3 machine set with vertical shaft and bearing housings which are all braced against the foundation, usually with operational speeds of between 60 r/min and 1 800 r/min