



Standard Practice for Sampling and the Amount of Testing of Hydraulic Cement¹

This standard is issued under the fixed designation C 183; the number immediately following the designation indicates the year of original adoption or, in the case of revision, the year of last revision. A number in parentheses indicates the year of last reapproval. A superscript epsilon (ϵ) indicates an editorial change since the last revision or reapproval.

This standard has been approved for use by agencies of the Department of Defense.

1. Scope

1.1 This practice covers procedures for sampling and for the amount of testing of hydraulic cement after it has been manufactured and is ready to be offered for sale.

1.2 The values stated in SI units are to be regarded as the standard. The inch-pound units in parentheses are for information purposes only.

1.2.1 A ton as used in this practice is 907 kg (2000 lb).

1.2.2 Values in SI units shall be obtained by measurement in SI units or by appropriate conversion, using the Rules for Conversion and Rounding given in Standard IEEE/ASTM SI 10, of measurement made in other units.

1.3 *This standard does not purport to address all of the safety concerns, if any, associated with its use. It is the responsibility of the user of this standard to establish appropriate safety and health practices and determine the applicability of regulatory limitations prior to use.*

2. Referenced Documents

2.1 ASTM Standards:

- C 91 Specification for Masonry Cement²
- C 109 Test Method for Compressive Strength of Hydraulic Cement Mortars (Using 2-in. or 50-mm Cube Specimens)²
- C 114 Test Methods for Chemical Analysis of Hydraulic Cement²
- C 115 Test Method for Fineness of Portland Cement by the Turbidimeter²
- C 150 Specification for Portland Cement²
- C 151 Test Method for Autoclave Expansion of Portland Cement²
- C 157 Test Method for Length Change of Hardened Hydraulic-Cement Mortar and Concrete³
- C 185 Test Method for Air Content of Hydraulic Cement Mortar²
- C 186 Test Method for Heat of Hydration of Hydraulic Cement²
- C 191 Test Method for Time of Setting of Hydraulic Cement by Vicat Needle²

- C 204 Test Method for Fineness of Hydraulic Cement by Air Permeability Apparatus²
 - C 227 Test Method for Potential Alkali Reactivity of Cement-Aggregate Combinations (Mortar-Bar Method)³
 - C 265 Test Method for Calcium Sulfate in Hydrated Portland Cement Mortar²
 - C 266 Test Method for Time of Setting of Hydraulic Cement Paste by Gillmore Needles²
 - C 451 Test Method for Early Stiffening of Hydraulic Cement (Paste Method)²
 - C 452 Test Method for Potential Expansion of Hydraulic Cement Mortars Exposed to Sulfate²
 - C 563 Test Method for Optimum SO₃ in Hydraulic Cement Using 24 h Compressive Strength²
 - C 595 Specification for Blended Hydraulic Cements²
 - C 845 Specification for Expansive Hydraulic Cement²
 - C 1012 Test Method for Length Change of Hydraulic-Cement Mortars Exposed to a Sulfate Solution²
 - E 11 Specification for Wire-Cloth Sieves for Testing Purposes⁴
 - IEEE/ASTM SI 10 Standard for Use of the International System of Units (SI): The Modern Metric System⁴
- #### 2.2 ACI Standard:
- 225.1R Guide to the Selection and Use of Hydraulic Cements⁵

3. Terminology

3.1 Definitions of Terms Specific to This Standard:

3.1.1 *lot (of cement)*—specific quantity of cement offered for inspection at any one time. A lot may be one or more storage bins filled consecutively. A lot may also be the contents of one or more transport units representing cement drawn from the same storage bin.

3.1.2 *reduced testing rate*—test program that provides for the testing of only two samples from any given lot of samples obtained and prepared for testing at the normal rate as described herein. The program utilizes probability factors and is so designed that when results from the two samples fulfill the requirements of the program it may be said with 95 % confidence that less than 5 % of the samples would be outside the specification limits.

¹ This practice is under the jurisdiction of ASTM Committee C-1 on Cement, and is the direct responsibility of Subcommittee C01.95 on Methods of Test.

Current edition approved Oct. 10, 1995. Published December 1995. Originally published as C 183 – 44. Last previous edition C 183 – 95.

² *Annual Book of ASTM Standards*, Vol 04.01.

³ *Annual Book of ASTM Standards*, Vol 04.02.

⁴ *Annual Book of ASTM Standards*, Vol 14.02.

⁵ Detailed requirements for this sieve are given in Specification E 11.

4. Significance and Use

4.1 The sampling procedures described are intended for use in the procurement of samples of hydraulic cement after it has been manufactured and is ready to be offered for sale. They are not intended as sampling procedures for quality control purposes during manufacturing. The testing procedures outlined cover the amount of testing to be done and provide guidance for reporting on conformance or non-conformance of cements with requirements of purchase specifications.

4.2 This practice is referenced as the procedure for sampling masonry cement (Specification C 91), portland cement (Specification C 150), blended hydraulic cement (Specification C 595), and expansive hydraulic cement (Specification C 845).

4.3 Most building codes and construction specifications require that hydraulic cement to be used in the work meet the applicable requirements of the relevant purchase specifications, such as Specifications C 91, C 150, C 595, or C 845. If the code or specification requires sampling of the manufactured cement, the provisions given in 4.4 are applicable. Not much cement is sold on the basis of such sampling and testing. A useful discussion of sampling and testing cement is contained in ACI 225.1R.

4.4 The procedures covered in this practice should be done by or for purchasers of hydraulic cement who are using a code or specification that requires sampling and testing to determine if the samples conform to the relevant acceptance specifications. The testing is done using specified methods to determine whether the samples yield test results that conform to the specification, and the tests serve as a basis for acceptance or rejection of the lot of material sampled.

4.5 It is neither intended nor required that all cements be tested using all the test methods referenced in Section 2.

5. Kinds and Size of Samples and by Whom Taken

5.1 A cement sample secured from a conveyor, from bulk storage, or from a bulk shipment in one operation, shall be termed a "grab sample." A sample obtained during a 10-min interval using an automatic sampling device that continuously samples a cement stream may also be termed a grab sample. Grab samples taken at prescribed intervals over a period of time may be combined to form a "composite sample" representative of the cement produced during that period of time.

5.2 All samples, whether grab or composite, shall have a mass of at least 5 kg (10 lb).

5.3 The purchaser may designate a representative to supervise the sampling, packing, and shipping of samples when it is so specified in the purchase contract.

5.4 Package the samples in moisture-proof, airtight containers numbered consecutively in the order in which the samples are taken. The purchase contract shall state who will pay for the costs of sampling, packaging, shipping and testing the samples.

NOTE 1—Polyvinyl chloride sample containers, upon occasion, have been found to affect the air-entraining potential of a cement sample. The same problem might be experienced with containers made from other plastics.

6. Testing-Time Requirements for the Completion of Tests

6.1 When tests of hydraulic cement are made at a laboratory

other than that of the cement manufacturer, the cement sampling schedule, sample transportation time, and sample testing schedule must be coordinated among the purchaser, the manufacturer, and the testing laboratory so that the tests results will be available when required.

6.2 The manufacturer of the cement shall make the cement available to be sampled for testing early enough before the time the test results are needed so that at least the applicable time intervals listed in 6.3 exist.

6.3 When this has been done, the testing laboratory shall provide test results not later than the indicated number of days after sampling:

Test Methods	Time Interval, days
C 109 (1-day results), C 114, C 115, C 151, C 185, C 191, C 204, C 451, C 265, C 266, C 563	8
C 109 (3-day results)	10
C 109 and C186 (7-day results)	14
C 227, C452, and C1012 (14-day results)	21
C 109 and C186 (28-day results)	35
C 157 (34-day results)	41
C 227 (56-day results)	63
C 227 (91-day results)	98

7. Sampling

7.1 The cement may be sampled by any of the applicable methods described in this section.

7.1.1 *From the Conveyor Delivering to Bulk Storage*—Take one grab sample, having a mass of at least 5 kg (10 lb), at approximately 6-h intervals.

7.1.2 *Transfer Sampling*—Sample cement in storage while the cement is being transferred from one bin to another. Take one grab sample from the transfer stream for each 360 Mg (400 tons) of cement, or fraction thereof, but take no less than two grab samples and combine them to produce a composite sample.

7.1.3 *Other Sampling Methods*—When neither of the above sampling methods is applicable, samples may, when authorized by the purchaser, be taken by one of the following methods:

7.1.3.1 *From Bulk Storage at Points of Discharge*—Withdraw cement from the discharge openings in a steady stream until sampling is completed. Estimate the quantity of cement in Mg to be withdrawn from one discharge opening as $0.055 d^3 \times 0.2$, where d is the depth in metres of cement above the discharge opening. If a high circular silo is being sampled, take all samples from one opening. If the quantity of the cement in the bin exceeds 1100 Mg (1200 tons) when low rectangular bins are being sampled, discharge openings employed in the sampling shall be such that for no opening shall the number of samples represent more than one half the contents of the bin or more than 1800 Mg (2000 tons). In sampling bulk storage at points of discharge, while the cement is flowing through the openings, take samples at such intervals so that at least two grab samples shall be secured for each 360 Mg (400 tons) in the bin or silo.

7.1.3.2 *From Bulk Storage and Bulk Shipment by Means of a Slotted Tube Sampler*—When the depth of the cement to be sampled does not exceed 2.1 m (7 ft), obtain samples using a slotted tube sampler similar to that shown in Fig. 1. It shall be between 1.5 and 1.8 m (5 and 6 ft) long and approximately 35 mm ($1\frac{3}{8}$ in.) in outside diameter and consist of two polished



FIG. 1 Slotted Tube Sampler for Bulk Cement

brass telescopic tubes with registering slots that are opened or closed by rotation of the inner tube, the outer tube being provided with a sharp point to facilitate penetration. Take samples from well-distributed points and various depths of the cement so that the samples taken will represent the cement involved.

7.1.3.3 From Packaged Cement by Means of Tube Sampler—Insert the sampler, shown in Fig. 2, diagonally into the valve of the bag and place the thumb over the air hole. Then withdraw the sampler. Take one sample from a bag in each 4.5 Mg (5 tons) or fraction thereof.

7.1.3.4 From Bulk Shipment of Car or Truck:

(a) *Single Shipment*—If only one car or truck is being loaded and the loading is continuous and all from the same source, take a 5-kg (10-lb) sample. If not continuous or unknown, combine five or more portions from different points in the load to form the test sample.

(b) *Multiple Shipments*—When the shipment consists of several cars or trucks loaded from the same source and on the same day, sample the shipment at the rate of one sample for each 90 Mg (100 tons) of cement or fraction thereof, but take not less than two samples. Consider cement represented by such samples as a lot, and test the samples in accordance with the procedure outlined in the section on Amount of Testing.

7.2 Protection of Samples—As samples are taken, place them directly in moisture-proof airtight containers to avoid moisture absorption and aeration of the sample. If the samples are placed in cans, fill the can completely and immediately seal. Use moisture-proof multiple-wall paper bags or plastic bags if they are strong enough to avoid breakage, and if they can be sealed immediately after filling in such a manner as to eliminate excess air in the sample and avoid moisture absorption and aeration of the sample. Samples shall be treated as described in the section on Preparation of Sample.

8. Preparation of Sample

8.1 Before testing, pass each sample through an 850- μ m (No. 20) sieve,⁶ or any other sieve having approximately the

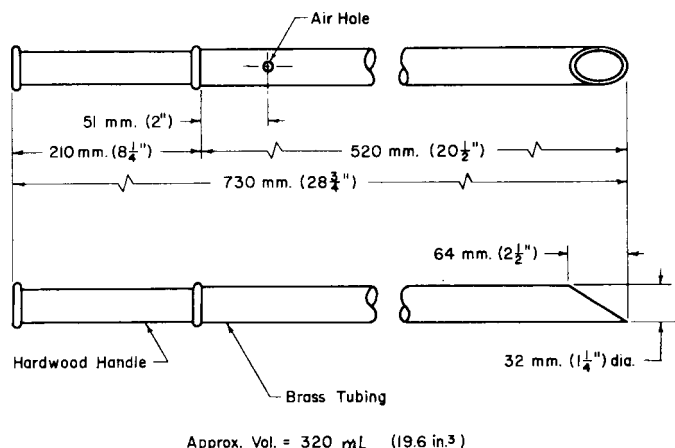

FIG. 2 Tube Sampler for Packaged Cement

same size openings, in order to mix the sample, break up lumps, and remove foreign material. Discard the foreign materials and hardened lumps that do not break up on sieving or brushing. Store the cement in airtight moisture-proof containers to prevent aeration or absorption of moisture prior to test.

9. Amount of Testing

9.1 General—When required, the purchaser shall specify the amount of testing for heat of hydration (Test Method C 186), alkali reactivity (Test Method C 227), and sulfate resistance (Test Method C 1012). Make all other tests on individual grab or composite samples chosen as specified herein under Selection of Samples for Testing. Do only those tests required by the applicable specification.

9.2 Normal Testing—Determine the number of samples to be tested in accordance with Table 1. The normal testing rate shall be used under the following conditions:

9.2.1 Before the quality history has been established,

9.2.2 When no samples from a particular mill have been tested within a year,

9.2.3 When the quality history is based entirely on data more than two years old, and

9.2.4 When it is deemed necessary to recalculate the critical limit because of indicated lack of control as shown by the control chart of the range.

NOTE 2—Random grab samples taken at inappropriate times, such as immediately following the repair or adjustment of manufacturing equipment, or from inappropriate places, such as from the top surface of the material in a car, will not suitably reflect the properties of a cement, and therefore should not be used as the basis for acceptance or rejection of a lot of cement.

9.3 Reduced Testing—After the quality history has been established, test at the reduced testing rate. If the results of these tests are within the critical range, make additional tests (total equal to the number of tests at the normal rate as shown in Table 1).

NOTE 3—When the quality history indicates that the results for a given requirement will probably be within the critical range, and substantial delay in completion of the tests would result from making additional tests (for example, compressive strength), it may be desirable to make the tests at the normal rate, rather than the reduced testing rate.

9.4 Selection of Samples for Testing—Take samples to be tested from each lot by some random method. The following method is suggested: Place a group of consecutively numbered

TABLE 1 Number of Samples for Test

Lot Size—Number of Samples	Number of Tests	
	Normal Rate	Reduced Rate
2	2	2
3	3	2
4 to 10	4	2
11 to 20	6	2
Over 20	8	2