



## Standard Test Methods for Resistance of Porcelain Enameled Utensils to Boiling Acid<sup>1</sup>

This standard is issued under the fixed designation C 283; the number immediately following the designation indicates the year of original adoption or, in the case of revision, the year of last revision. A number in parentheses indicates the year of last reapproval. A superscript epsilon ( $\epsilon$ ) indicates an editorial change since the last revision or reapproval.

### 1. Scope

1.1 These test methods cover the determination of the resistance of porcelain enamel coatings used on utensils to attack by boiling acid.

1.2 *This standard does not purport to address all of the safety concerns, if any, associated with its use. It is the responsibility of the user of this standard to establish appropriate safety and health practices and determine the applicability of regulatory limitations prior to use.*

### 2. Significance and Use

2.1 Test Method A provides the producers of porcelain enameled utensils with a quality control method of testing for resistance to boiling acid for parts randomly selected from the production line.

2.2 Test Method B provides the supplier of porcelain enamel raw materials with a laboratory method for testing the resistance of different coatings (intended for use on utensils) to boiling acid.

### TEST METHOD A

### 3. Apparatus

3.1 *Hot Plate*, capable of maintaining over its entire surface a uniform temperature that will keep the test solution at a rolling boil (see section 7.5). The heating element should occupy an area at least 8 in. (203 mm) in diameter.

3.2 *Chemical Glassware*—Beakers, a desiccator, and a 500-mL graduated cylinder.

3.3 *Drier*, capable of maintaining a temperature of at least 220°F (104°C).

3.4 *Boiling Acid Resistance Apparatus*, as shown in Fig. 1. Three sets will be required.

3.5 *Cutting Equipment*, suitable for cutting a 3/4 -in. (82-mm) diameter plate from the bottom of a porcelain-enameled steel utensil, as follows:

3.5.1 *Punch and Die* (Fig. 2),

3.5.2 *Shears*,

3.5.3 *Abrasive Cut-off Wheel*,

3.5.4 *Cutting Torch*, or

3.5.5 *Any Other Suitable Equipment*

3.6 *Analytical Balance*, having a sensitivity of 0.0001 g.

### 4. Reagent

4.1 The test solution shall contain 6 g of ACS grade citric acid per 94 g of distilled water and shall be prepared fresh for each test.

### 5. Test Specimens

5.1 The test specimens shall consist of three plates, 3/4 in. (82 mm) in diameter, cut from the bottoms of three identical utensils.

NOTE 1—“Identical utensils” signifies utensils of the same size, shape, and finish.

### 6. Preparation of Test Specimens

6.1 After the test specimens have been cut from the utensils, file their edges with a triangular file to remove any loose enamel chips.

6.2 Thoroughly wash the test specimens with soap and water to remove any grease picked up in handling. Rinse with distilled water. Place the specimens in a drier at 220°F (104°C). After 10 min, remove the test specimens and place them in a desiccator containing calcium chloride.

### 7. Procedure

7.1 Level the hot plate, turn the switch on in the high heat position, and allow to preheat for at least 1 h to obtain a uniform temperature over the entire heating element.

7.2 Remove the test specimens, one at a time, from the desiccator, hold at the edges, and inspect the edges for loose chips. Remove any chips found, before the initial weighing.

7.3 Weigh each specimen on an analytical balance, recording its weight to the nearest 0.0001 g.

7.4 Place the heat-resistant gasket above the hole in the base-plate of the boiling-acid resistance apparatus (Fig. 1). Place the test specimen over the gasket, with the surface from the inside of the utensil up. Next, place a rubber jar ring on the test specimen. This serves as a seal between the test specimen and the heat-resistant glass tube, which shall be placed over it.

<sup>1</sup> These test methods are under the jurisdiction of ASTM Committee B-8 on Metallic and Inorganic Coatings and are the direct responsibility of Subcommittee B08.12 on Materials for Porcelain Enamel and Ceramic-Metal Systems.

Current edition approved Oct. 10, 1997. Published March 1998. Originally published as C283 – 51. Last previous edition C283 – 54 (1993).

Test Method A is based on the boiling acid resistance test developed by the Enameled Utensil Manufacturers' Council; see Section 16 of Commercial Standard CS100-47, Porcelain Enameled Steel Utensils, United States Department of Commerce.

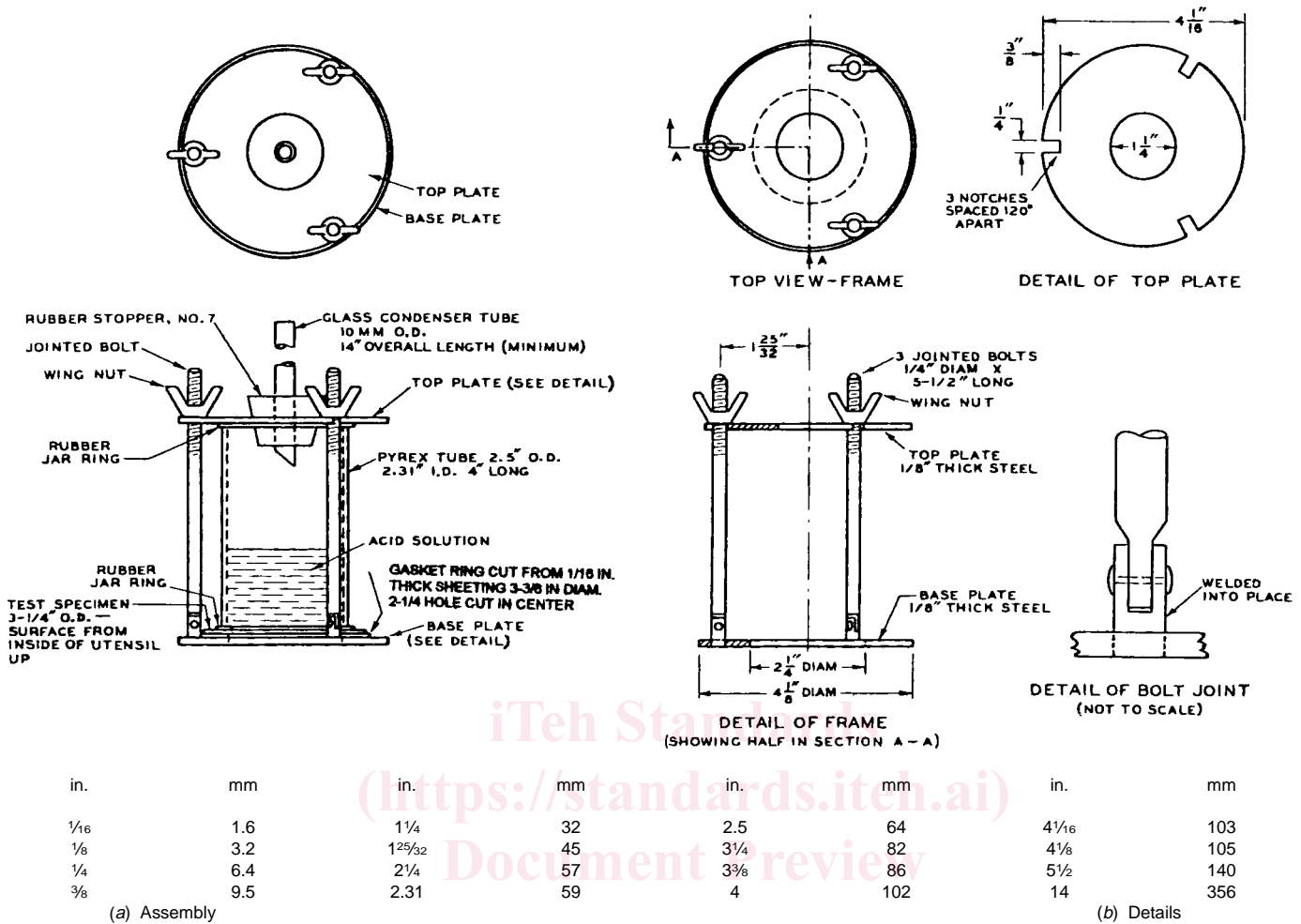

FIG. 1 Boiling-Acid Resistance Apparatus

Place another rubber jar ring on top of the glass tube, set the cover-plate on it, and clamp in place by tightening the wing nuts. Tighten the wing nuts until a seal is obtained between the glass tube and the test specimen. This can be determined by inspecting the seal ring, when the nuts are tight enough, the outside edges of the rubber jar rings will lift from the test specimen. Use the bottom jar rings only twice (once on each side); then discard for new ones.

7.5 Bring approximately 500 mL of the citric acid solution to boiling, pour 150 mL of the solution into each glass tube, and set the glass condensing tubes in position. Promptly center the three test units on the hot plate, as shown in Fig. 3, and leave the test units in place for a period of 2 1/2 h. After the solutions begin to boil, decrease the wattage input so that the solutions remain at a rolling boil for the remainder of the test period.

7.6 At the end of the test period, remove the units and condenser tubes from the hot plate and pour out the solutions, then rinse the insides of the tubes and the test specimens with distilled water, and dismantle the apparatus. Remove the test specimens, rinse again with distilled water scrub the test specimens gently with a nylon brush (10 to 12 strokes) to remove loose residue in the attack area, and dry in the drier at

220°F (104°C) for 10 min. Place the specimens in a desiccator and cool to room temperature.

7.7 After the test specimens are cool, again weigh them separately on the analytical balance.

### 8. Calculations and Report

8.1 The difference between the initial and the final weight of each specimen, divided by four, gives the loss in weight per square inch of exposed area (wetted surface) (Note 2). Take the average loss per square inch for three specimens from three identical utensils for the boiling-acid resistance of the enamel.

NOTE 2—Wetted surface area is that surface which is attacked by the test solution.

8.2 If, however, any one of the three results does not agree within ±10 % of the average, another set of three plates from utensils identical with those of the first set shall be tested. The individual values of loss in weight per square inch for the second set of plates shall be averaged with the individual values of the first set, any individual value not within ±10 % of the average for the six plates shall be discarded, and the average of the remaining values shall be taken as the boiling-acid resistance of the enamel.