



Standard Test Methods for Notched Bar Impact Testing of Metallic Materials¹

This standard is issued under the fixed designation E 23; the number immediately following the designation indicates the year of original adoption or, in the case of revision, the year of last revision. A number in parentheses indicates the year of last reapproval. A superscript epsilon (ϵ) indicates an editorial change since the last revision or reapproval.

This standard has been approved for use by agencies of the Department of Defense.

1. Scope

1.1 These test methods describe notched-bar impact testing of metallic materials by the Charpy (simple-beam) test and the Izod (cantilever-beam) test. They give the requirements for: test specimens, test procedures, test reports, test machines (see Annex A1) verifying Charpy impact machines (see Annex A2), optional test specimen configurations (see Annex A3), pre-cracking Charpy V-notch specimens (see Annex A4), designation of test specimen orientation (see Annex A5), and determining the percent of shear fracture on the surface of broken impact specimens (see Annex A6). In addition, information is provided on the significance of notched-bar impact testing (see Appendix X1), methods of measuring the center of strike (see Appendix X2), and the availability of Charpy V-notch verification specimens (see Appendix X3).

1.2 These test methods do not address the problems associated with impact testing at temperatures below $-196\text{ }^{\circ}\text{C}$ ($-320\text{ }^{\circ}\text{F}$, $77\text{ }^{\circ}\text{K}$).

1.3 The values stated in SI units are to be regarded as the standard. Inch-pound units are provided for information only.

1.4 *This standard does not purport to address all of the safety concerns, if any, associated with its use. It is the responsibility of the user of this standard to establish appropriate safety and health practices and determine the applicability of regulatory limitations prior to use.* Specific precautionary statements are given in Section 5.

2. Referenced Documents

2.1 ASTM Standards:

E 177 Practice for Use of the Terms Precision and Bias in ASTM Test Methods²

E 399 Test Method for Plane-Strain Fracture Toughness of Metallic Materials³

E 604 Test Method for Dynamic Tear Energy of Metallic Materials³

E 691 Practice for Conducting an Interlaboratory Study to Determine the Precision of a Test Method²

¹ These test methods are under the jurisdiction of ASTM Committee E28 on Mechanical Testing and are the direct responsibility of Subcommittee E2807 on Impact Testing.

Current edition approved April 10, 2001. Published June 2001. Originally published as E 23 – 33 T. Last previous edition E 23 – 00.

² *Annual Book of ASTM Standards*, Vol 14.02.

³ *Annual Book of ASTM Standards*, Vol 03.01.

E 1271 Practice for Qualifying Charpy Verification Specimens of Heat-treated Steel³

E 1313 Guide for Recommended Formats for Data Records Used in Computerization of Mechanical Test Data for Metals⁴

3. Summary of Test Method

3.1 The essential features of an impact test are: a suitable specimen (specimens of several different types are recognized), an anvil or support on which the test specimen is placed to receive the blow of the moving mass, a moving mass that has sufficient energy to break the specimen placed in its path, and a device for measuring the energy absorbed by the broken specimen.

4. Significance and Use

4.1 These test methods of impact testing relate specifically to the behavior of metal when subjected to a single application of a force resulting in multi-axial stresses associated with a notch, coupled with high rates of loading and in some cases with high or low temperatures. For some materials and temperatures the results of impact tests on notched specimens, when correlated with service experience, have been found to predict the likelihood of brittle fracture accurately. Further information on significance appears in Appendix X1.

5. Precautions in Operation of Machine

5.1 Safety precautions should be taken to protect personnel from the swinging pendulum, flying broken specimens, and hazards associated with specimen warming and cooling media.

6. Apparatus

6.1 General Requirements:

6.1.1 The testing machine shall be a pendulum type of rigid construction.

6.1.2 The testing machine shall be designed and built to conform with the requirements given in Annex A1.

6.2 Inspection and Verification

6.2.1 Inspection procedures to verify impact machines directly are provided in A2.2 and A2.3. The items listed in A2.2 must be inspected annually.

6.2.2 The procedures to verify Charpy V-notch machines

⁴ *Annual Book of ASTM Standards*, Vol 14.01.

indirectly, using verification specimens, are given in A2.4. Charpy impact machines must be verified annually.

7. Test Specimens

7.1 Configuration and Orientation:

7.1.1 Specimens shall be taken from the material as specified by the applicable specification. Specimen orientation should be designated according to the terminology given in Annex A5.

7.1.2 The type of specimen chosen depends largely upon the characteristics of the material to be tested. A given specimen may not be equally satisfactory for soft nonferrous metals and hardened steels; therefore, many types of specimens are recognized. In general, sharper and deeper notches are required to distinguish differences in very ductile materials or when using low testing velocities.

7.1.3 The specimens shown in Figs. 1 and 2 are those most widely used and most generally satisfactory. They are particularly suitable for ferrous metals, excepting cast iron.⁵

7.1.4 The specimen commonly found suitable for die-cast alloys is shown in Fig. 3.

7.1.5 The specimens commonly found suitable for powdered metals (P/M) are shown in Figs. 4 and 5. The specimen

surface may be in the as-produced condition or smoothly machined, but polishing has proven generally unnecessary. Unnotched specimens are used with P/M materials. In P/M materials, the impact test results are affected by specimen orientation. Therefore, unless otherwise specified, the position of the specimen in the machine shall be such that the pendulum will strike a surface that is parallel to the compacting direction.

7.1.6 Sub-size and supplementary specimen recommendations are given in Annex A3.

7.2 Specimen Machining:

7.2.1 When heat-treated materials are being evaluated, the specimen shall be finish machined, including notching, after the final heat treatment, unless it can be demonstrated that the impact properties of specimens machined before heat treatment are identical to those machined after heat treatment.

7.2.2 Notches shall be smoothly machined but polishing has proven generally unnecessary. However, since variations in notch dimensions will seriously affect the results of the tests, adhering to the tolerances given in Fig. 1 is necessary (Appendix X1.2 illustrates the effects from varying notch dimensions on Type A specimens). In keyhole specimens, the round hole shall be carefully drilled with a slow feed rate. The slot may be cut by any feasible method, but care must be exercised in cutting the slot to ensure that the surface of the drilled hole opposite the slot is not damaged.

⁵ Report of Subcommittee XV on Impact Testing of Committee A-3 on Cast Iron, Proceedings, ASTM, Vol 33 Part 1, 1933.

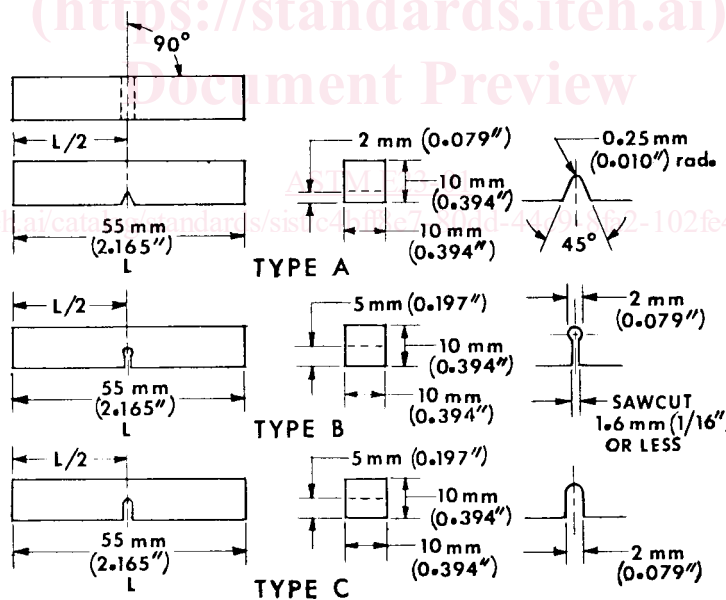

NOTE 1—Permissible variations shall be as follows:

Notch length to edge	90 ± 2°
Adjacent sides shall be at	90° ± 10 min
Cross-section dimensions	± 0.075 mm (± 0.003 in.)
Length of specimen (L)	+0, -2.5 mm (+0, -0.100 in.)
Centering of notch (L/2)	± 1 mm (± 0.039 in.)
Angle of notch	± 1°
Radius of notch	± 0.025 mm (± 0.001 in.)
Notch depth:	
Type A specimen	± 0.025 mm (± 0.001 in.)
Types B and C specimen	± 0.075 mm (± 0.003 in.)
Finish requirements	2 µm (63 µin.) on notched surface and opposite face; 4 µm (125 µin.) on other two surfaces

FIG. 1 Charpy (Simple-Beam) Impact Test Specimens, Types A, B, and C

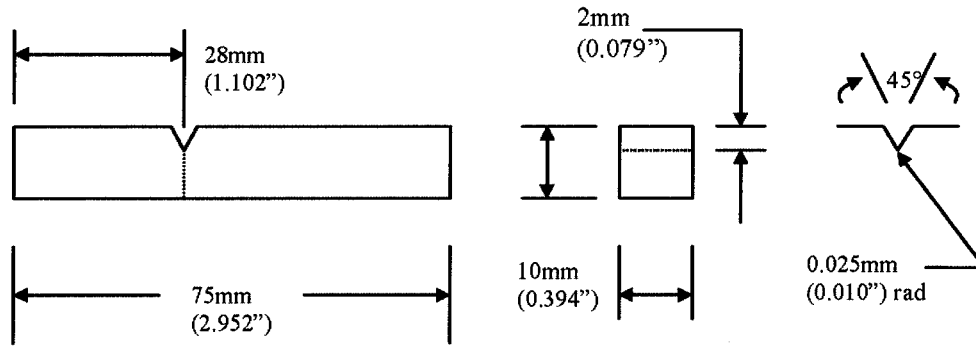

NOTE 1—Permissible variations shall be as follows:

Notch length to edge	90 ± 2°
Cross-section dimensions	±0.025 mm (±0.001 in.)
Length of specimen	+0, -2.5 mm (±0, -0.100 in.)
Angle of notch	±1°
Radius of notch	±0.025 mm (±0.001 in.)
Notch depth	±0.025 mm (±0.001 in.)
Adjacent sides shall be at	90° ± 10 min
Finish requirements	2 μm (63 μin.) on notched surface and opposite face; 4 μm (125 μin.) on other two surfaces

FIG. 2 Izod (Cantilever-Beam) Impact Test Specimen, Type D

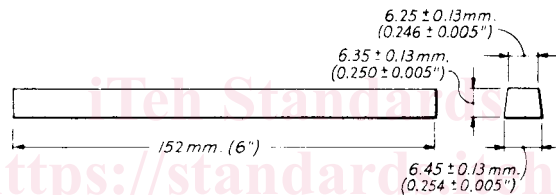

NOTE 1—Two Izod specimens may be cut from this bar.

NOTE 2—Blow shall be struck on narrowest face.

FIG. 3 Izod Impact Test Bar for Die Castings Alloys

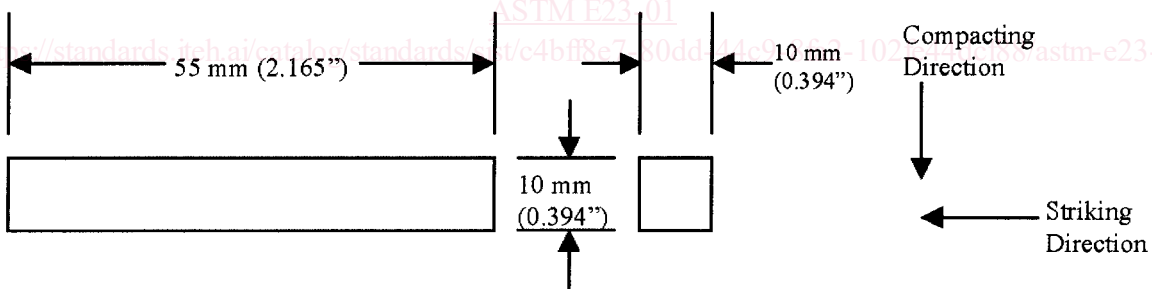

NOTE 1—Permissible variations shall be as follows:

Adjacent sides shall be at	90° ± 10 min
Cross section dimensions	±0.125 mm (0.005 in.)
Length of specimen	+0, -2.5 mm (+0, -0.100 in.)

FIG. 4 Charpy (Simple Beam) Impact Test Specimens for Metal Powder Structural Parts

7.2.3 Identification marks shall only be placed in the following locations on specimens: either of the 10-mm square ends; the side of the specimen that faces up when the specimen is positioned in the anvils (see Note 1); or the side of the specimen opposite the notch. No markings, on any side of the specimen, shall be within 15 mm of the center line of the notch. An electrostatic pencil may be used for identification purposes, but caution must be taken to avoid excessive heat.

NOTE 1—Careful consideration should be given before placing identification marks on the side of the specimen to be placed up when positioned

in the anvils. If the test operator is not careful, the specimen may be placed in the machine with the identification marking resting on the specimen supports. Under these circumstances, the absorbed energy value obtained may be unreliable.

8. Procedure

8.1 Preparation of the Apparatus:

8.1.1 Perform a routine procedure for checking impact machines at the beginning of each day, each shift, or just prior to testing on a machine used intermittently. It is recommended that the results of these routine checks be kept in a log book for

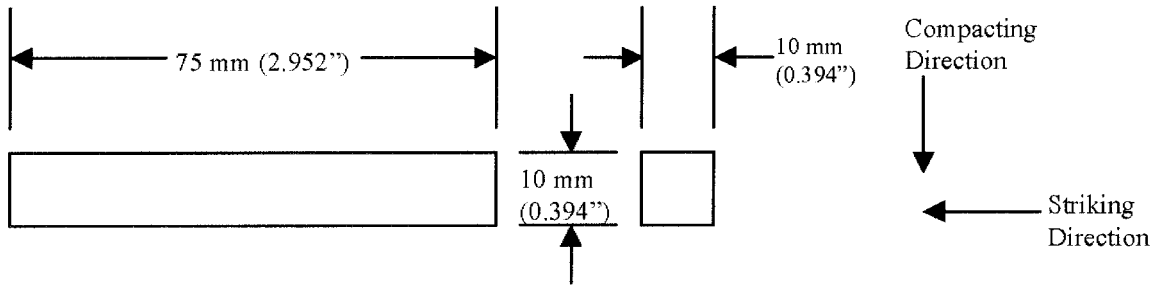

NOTE 1—Permissible variations shall be as follows:

Adjacent sides shall be at	90° ± 10 min.
Cross section dimensions	±0.125 mm (0.005 in.)
Length of specimens	+0, -2.5 mm (+0, -0.100 in.)

FIG. 5 Izod (Cantilever-Beam) Impact Test Specimen for Metal Powder Structural Parts

the machine. After the testing machine has been ascertained to comply with Annex A1 and Annex A2, carry out the routine check as follows:

8.1.1.1 Visually examine the striker and anvils for obvious damage and wear.

8.1.1.2 Check the zero position of the machine by using the following procedure: raise the pendulum to the latched position, move the pointer to near the maximum capacity of the range being used, release the pendulum, and read the indicated value. The pointer should indicate zero on machines reading directly in energy. On machines reading in degrees, the reading should correspond to zero on the conversion chart furnished by the machine manufacturer.

NOTE 2—On machines that do not compensate for windage and friction losses, the pointer will not indicate zero. In this case, the indicated values, when converted to energy, shall be corrected for frictional losses that are assumed to be proportional to the arc of swing.

8.1.1.3 To ensure that friction and windage losses are within allowable tolerances, the following procedure is recommended: raise the pendulum to the latched position, move the pointer to the negative side of zero, release the pendulum and allow it to cycle five times (a forward and a backward swing together count as one swing), prior to the sixth forward swing, set the pointer to between 5 and 10 % of the scale capacity of the dial, after the sixth forward swing (eleven half swings), record the value indicated by the pointer, convert the reading to energy (if necessary), divide it by 11 (half swings), then divide by the maximum scale value being used and multiply it by 100 to get the percent friction. The result, friction and windage loss, shall not exceed 0.4 % of scale range capacity being tested and should not change by more than 5 % of friction measurements previously made on the machine. If the friction and windage loss value does exceed 0.4 % or is significantly different from previous measurements, check the indicating mechanism, the latch height, and the bearings for wear and damage. However, if the machine has not been used recently, let the pendulum swing for 50 to 100 cycles, and repeat the friction test before undertaking repairs to the machine.

8.2 Test Temperature Considerations:

8.2.1 The temperature of testing affects the impact properties of most materials. For materials with a body centered cubic structure, a transition in fracture mode occurs over a tempera-

ture range that depends on the chemical composition and microstructure of the material. Test temperatures may be chosen to characterize material behavior at fixed values, or over a range of temperatures to characterize the transition region, lower shelf, or upper shelf behavior, or all of these. The choice of test temperature is the responsibility of the user of this test method and will depend on the specific application.

8.2.2 The temperature of a specimen can change significantly during the interval it is removed from the temperature conditioning environment, transferred to the impact machine, and the fracture event is completed (see Note 5). When using a heating or cooling medium near its boiling point, use data from the references in Note 5 or calibration data with thermocouples to confirm that the specimen is within the stated temperature tolerances when the striker contacts the specimen. If excessive adiabatic heating is expected, monitor the specimen temperature near the notch during fracture.

8.2.3 Verify temperature-measuring equipment at least every six months. If liquid-in-glass thermometers are used, an initial verification shall be sufficient, however, the device shall be inspected for problems, such as the separation of liquid, at least twice annually.

8.2.4 Hold the specimen at the desired temperature within ± 1 °C (± 2 °F) in the temperature conditioning environment (see 8.2.4.1 and 8.2.4.2). Any method of heating or cooling or transferring the specimen to the anvil(s) may be used provided the temperature of the specimen immediately prior to fracture is essentially the same as the holding temperature (see Note 5). The maximum change in the temperature of the specimen allowed for the interval between the temperature conditioning treatment and impact is not specified here, because it is dependent on the material being tested and the application. The user of nontraditional or lesser used temperature conditioning and transfer methods (or sample sizes) shall show that the temperature change for the specimen prior to impact is comparable to or less than the temperature change for a standard size specimen of the same material that has been thermally conditioned in a commonly used medium (oil, air, nitrogen, acetone, methanal), and transferred for impact within 5 seconds (see Note 5). Three temperature conditioning and transfer methods used in the past are: liquid bath thermal

conditioning and transfer to the specimen supports with centering tongs; furnace thermal conditioning and robotic transfer to the specimen supports; placement of the specimen on the supports followed by in situ heating and cooling.

8.2.4.1 For liquid bath cooling or heating use a suitable container, which has a grid or another type of specimen positioning fixture. Cover the specimens, when immersed, with at least 25 mm (1 in.) of the liquid, and position so that the notch area is not closer than 25 mm (1 in.) to the sides or bottom of the container, and no part of the specimen is in contact with the container. Place the device used to measure the temperature of the bath in the center of a group of the specimens. Agitate the bath and hold at the desired temperature within $\pm 1^\circ\text{C}$ ($\pm 2^\circ\text{F}$). Thermally condition the specimens for at least 5 min before testing, unless a shorter thermal conditioning time can be shown to be valid by measurements with thermocouples. Leave the mechanism (tongs, for example) used to handle the specimens in the bath for at least 5 min before testing, and return the mechanism to the bath between tests.

8.2.4.2 When using a gas medium, position the specimens so that the gas circulates around them and hold the gas at the desired temperature within $\pm 1^\circ\text{C}$ ($\pm 2^\circ\text{F}$) for at least 30 min. Leave the mechanism used to remove the specimen from the medium in the medium except when handling the specimens.

NOTE 3—Temperatures up to $+260^\circ\text{C}$ ($+500^\circ\text{F}$) may be obtained with

certain oils, but “flash-point” temperatures must be carefully observed.
NOTE 4—For testing at temperatures down to -196°C (-320°F , 77°K), standard testing procedures have been found to be adequate for most metals.

NOTE 5—A study has shown that a specimen heated to 100°C in water can cool 10°C in the 5 s allowed for transfer to the machine supports (1)⁶. Other studies, using cooling media that are above their boiling points at room temperature have also shown large changes in specimen temperature during the transfer of specimens to the machine anvils. In addition, some materials change temperature dramatically during impact testing at cryogenic temperatures due to adiabatic heating (2).

8.3 Charpy Test Procedure:

8.3.1 The Charpy test procedure may be summarized as follows: the test specimen is thermally conditioned and positioned on the specimen supports against the anvils; the pendulum is released without vibration, and the specimen is impacted by the striker. Information is obtained from the machine and from the broken specimen.

8.3.2 To position a test specimen in the machine, it is recommended that self-centering tongs similar to those shown in Fig. 6 be used (see A1.10.1). The tongs illustrated in Fig. 6 are for centering V-notch specimens. If keyhole specimens are used, modification of the tong design may be necessary. If an end-centering device is used, caution must be taken to ensure

⁶ The boldface numbers given in parentheses refer to a list of references at the end of the text.

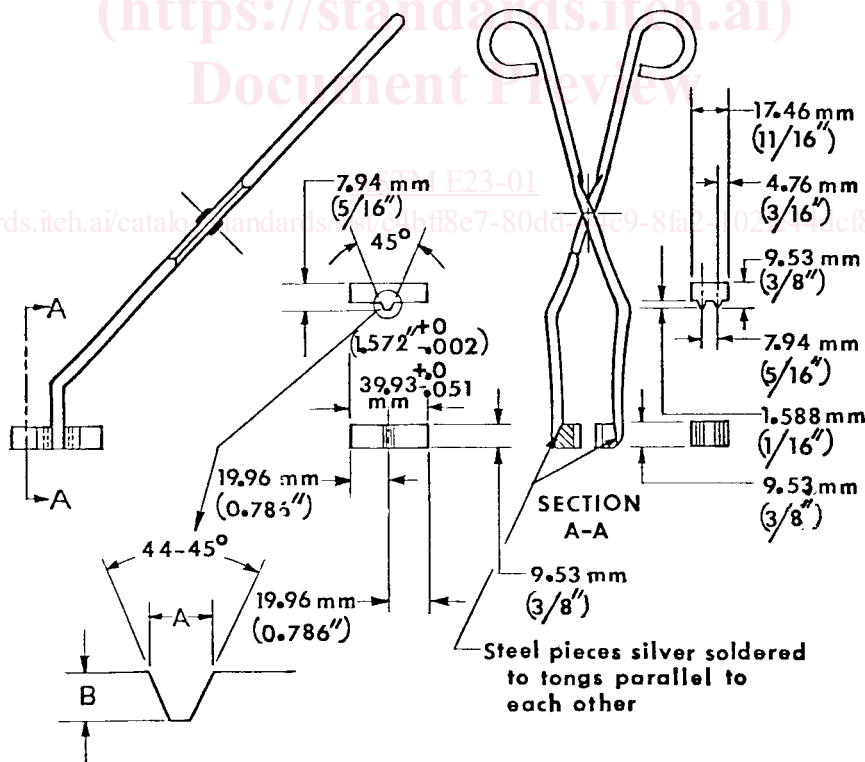

NOTE 1—Unless otherwise shown, permissible variation shall be ± 1 mm (0.04 in.).

Specimen Depth, mm (in.)	Base Width (A), mm (in.)	Height (B), mm (in.)
10 (0.394)	1.60 to 1.70 (0.063 to 0.067)	1.52 to 1.65 (0.060 to 0.065)
5 (0.197)	0.74 to 0.80 (0.029 to 0.033)	0.69 to 0.81 (0.027 to 0.032)
3 (0.118)	0.45 to 0.51 (0.016 to 0.020)	0.36 to 0.48 (0.014 to 0.019)

FIG. 6 Centering Tongs for V-Notch Charpy Specimens

that low-energy high-strength specimens will not rebound off this device into the pendulum and cause erroneously high recorded values. Many such devices are permanent fixtures of machines, and if the clearance between the end of a specimen in test position and the centering device is not approximately 13 mm (0.5 in.), the broken specimens may rebound into the pendulum.

8.3.3 To conduct the test, prepare the machine by raising the pendulum to the latched position, set the energy indicator at the maximum scale reading, or initialize the digital display, or both, position the specimen on the anvils, and release the pendulum. If a liquid bath or gas medium is being used for thermal conditioning, perform the following sequence in less than 5 s (for standard $10 \times 10 \times 55$ mm specimens, see 8.2.4). Remove the test specimen from its cooling (or heating) medium with centering tongs that have been temperature conditioned with the test specimen, place the specimen in the test position, and, release the pendulum smoothly. If a test specimen has been removed from the temperature conditioning bath and it is questionable that the test can be conducted within the 5 s time frame, return the specimen to the bath for the time required in 8.2 before testing.

8.3.3.1 If a fractured impact specimen does not separate into two pieces, report it as unbroken. Unbroken specimens with absorbed energies of less than 80 % of the machine capacity may be averaged with values from broken specimens. If the individual values are not listed, report the percent of unbroken specimens with the average. If the absorbed energy exceeds 80 % of the machine capacity and the specimen passes completely between the anvils, report the value as approximate (see 10.1) and not averaged with the others. If an unbroken specimen does not pass between the machine anvils, the result will be reported as exceeding the machine capacity. A specimen shall never be struck more than once.

8.3.3.2 If a specimen jams in the machine, disregard the results and check the machine thoroughly for damage or maladjustment, which would affect its calibration.

8.3.3.3 To prevent recording an erroneous value, caused by jarring the indicator when locking the pendulum in its upright ("ready") position, read the value for each test from the indicator prior to locking the pendulum for the next test.

8.4 Izod Test Procedure:

8.4.1 The Izod test procedure may be summarized as follows: the test specimen is positioned in the specimen-holding fixture and the pendulum is released without vibration. Information is obtained from the machine and from the broken specimen. The details are described as follows:

8.4.2 Testing at temperatures other than room temperature is difficult because the specimen-holding fixture for Izod specimens is often part of the base of the machine and cannot be readily cooled (or heated). Consequently, Izod testing is not recommended at other than room temperature.

8.4.3 Clamp the specimen firmly in the support vise so that the centerline of the notch is in the plane of the top of the vise within 0.125 mm (0.005 in.). Set the energy indicator at the maximum scale reading, and release the pendulum smoothly. Sections 8.3.3.1-8.3.3.3 inclusively, also apply when testing Izod specimens.

9. Information Obtainable from Impact Tests

9.1 *The absorbed energy* shall be taken as the difference between the energy in the striking member at the instant of impact with the specimen and the energy remaining after breaking the specimen. This value is determined by the machine's scale reading which has been corrected for windage and friction losses.

NOTE 6—Alternative means for energy measurement are acceptable provided the accuracy of such methods can be demonstrated. Methods used in the past include optical encoders and strain gaged strikers.

9.2 *Lateral expansion measurement* methods must take into account the fact that the fracture path seldom bisects the point of maximum expansion on both sides of a specimen. One half of a broken specimen may include the maximum expansion for both sides, one side only, or neither. Therefore, the expansion on each side of each specimen half must be measured relative to the plane defined by the undeformed portion on the side of the specimen, as shown in Fig. 7. For example, if A_1 is greater than A_2 , and A_3 is less than A_4 , then the lateral expansion is the sum of $A_1 + A_4$.

9.2.1 Before making any expansion measurements, it is essential that the two specimen halves are visually examined for burrs that may have formed during impact testing; if the burrs will influence the lateral expansion measurements, they must be removed (by rubbing on emery cloth or any other suitable method), making sure that the protrusions to be measured are not rubbed during the removal of the burr. Then, examine each fracture surface to ascertain that the protrusions have not been damaged by contacting an anvil, a machine mounting surface, ect. Lateral expansion shall not be measured on a specimen with this type of damage.

9.2.2 Lateral expansion shall not be reported for specimens that did not separate into two halves during the impact test, with one exception. The lateral expansion of an unbroken specimen can be reported if the following two conditions are met: the specimen can be separated by pushing the hinged halves together once and then pulling them apart without further fatiguing the specimen, and the lateral expansion measured for the unbroken specimen (prior to bending) is equal to or greater than that measured for the separated halves.

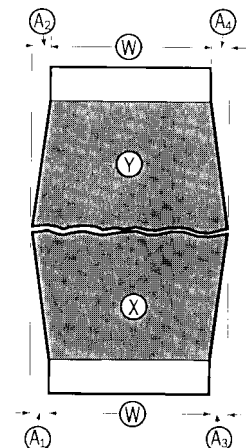

FIG. 7 Halves of Broken Charpy V-Notch Impact Specimen Illustrating the Measurement of Lateral Expansion, Dimensions A_1 , A_2 , A_3 , A_4 and Original Width, Dimension W

9.2.3 Lateral expansion may be measured easily by using a gage like the one shown in Fig. 8 (assembly and details shown in Fig. 9). Using this type of gage the measurement is made with the following procedure: orient the specimen halves so that the compression sides are facing each other, take one half of the fractured specimen and press it against the anvil and dial gage plunger and record the reading, make a similar measurement on the other half (same side) of the fractured specimen and disregard the lower of the two values, do the same for the other side of the fractured specimen, report the sum of the maximum expansions for the 2 sides as the lateral expansion for the specimen.

9.3 The percentage of shear fracture on the fracture surfaces of impact specimens may be determined using a variety of methods. The acceptable methods are defined in Annex A6. For each method, the user must distinguish between regions formed by ductile stable crack growth mechanisms, and regions formed by brittle fast crack propagation (unstable crack growth mechanisms). The typical zones of fracture appearance are shown in Fig. 10, where the “flat fracture” region is the region in which unstable crack growth occurs on a microsecond time scale.

The percent shear area on the fracture surface of a Charpy impact specimen is typically calculated as the difference between the total fractured area and the area of flat fracture. The measurement methods described here provide estimates for the area of the macroscopically flat fracture region (directly or indirectly), but do not consider details of the fracture mode for this “flat” region of unstable fracture. The flat fracture region could be 100 percent cleavage, a mixture of cleavage and ductile-dimple fracture morphologies, or other combinations of ductile-brittle fracture morphologies. Estimates of ductility within the unstable crack growth region are beyond the scope of these methods.

10. Report

10.1 Absorbed energy values above 80 % of the scale range are inaccurate and shall be reported as approximate. Ideally an impact test would be conducted at a constant impact velocity. In a pendulum-type test, the velocity decreases as the fracture progresses. For specimens that have impact energies approaching 80 % of the capacity of the pendulum, the velocity of the pendulum decreases (to about 45 % of the initial velocity) during fracture to the point that accurate impact energies are no longer obtained.

10.2 For commercial acceptance testing, report the following information (for each specimen tested):

10.2.1 Specimen type (and size if not the full-size specimen),

10.2.2 Test temperature,

10.2.3 Absorbed energy, and

10.2.4 Any other contractual requirements.

10.3 For other than commercial acceptance testing the following information is often reported in addition to the information in 10.2:

10.3.1 Lateral expansion,

10.3.2 Unbroken specimens,

10.3.3 Fracture appearance (% shear, See Note A6.1),

10.3.4 Specimen orientation, and

10.3.5 Specimen location.

NOTE 7—A recommended format for computerization of notched bar impact test data is available in Practice E 1313.

11. Precision and Bias

11.1 An Interlaboratory study used CVN specimens of low energy and of high energy to find sources of variation in the CVN absorbed energy. Data from 29 laboratories were included with each laboratory testing one set of five specimens of

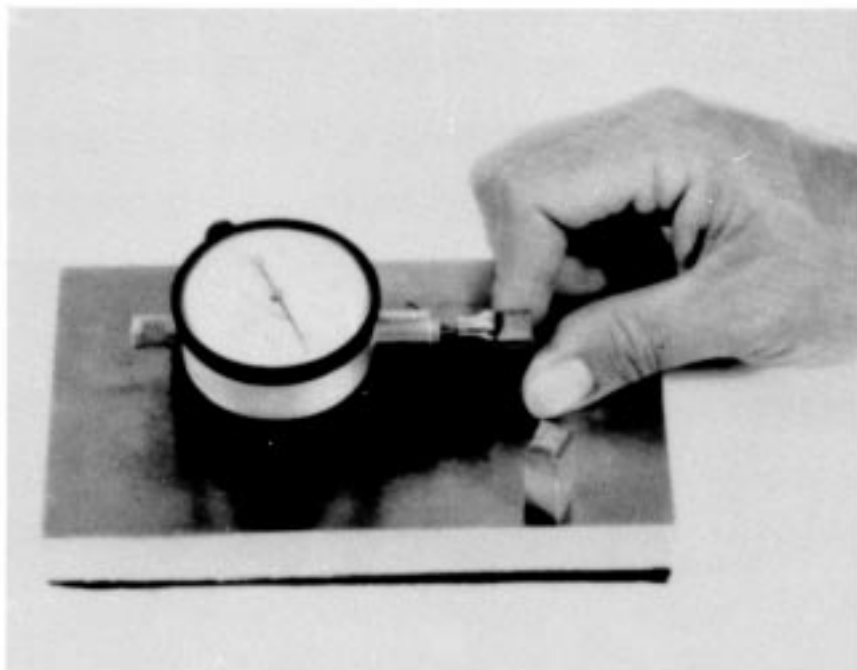

FIG. 8 Lateral Expansion Gage for Charpy Impact Specimens

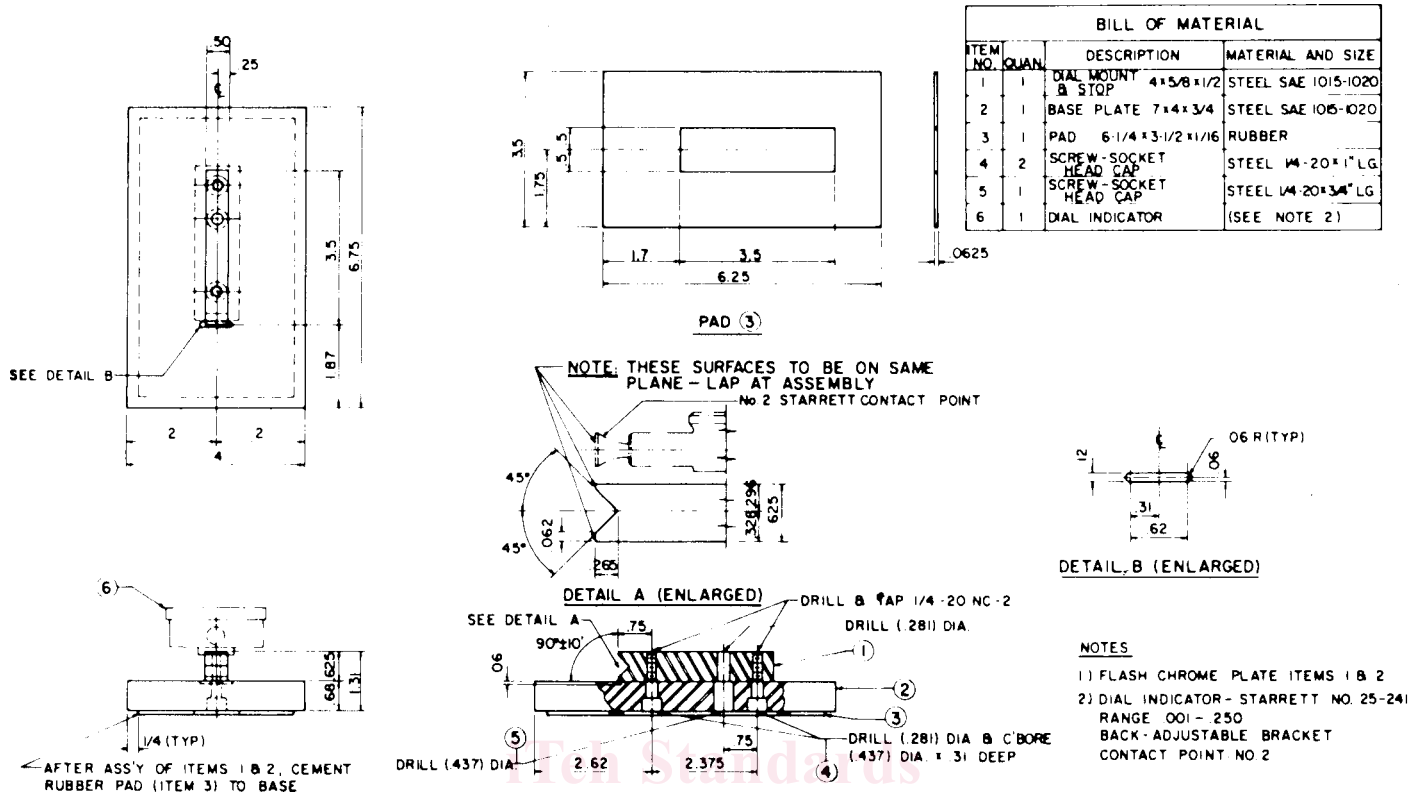
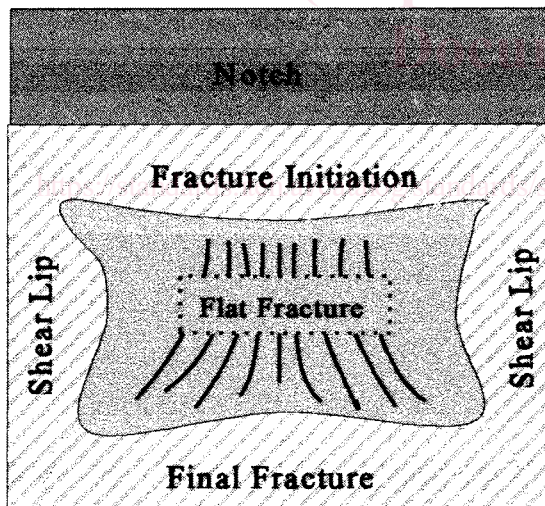

FIG. 9 Assembly and Details for Lateral Expansion Gage



NOTE 1—The shear of ductile fracture regions on the fracture surface include the fracture initiation region, the two shear lips, and the region of final fracture. The flat or radial fracture region is a region of less ductile unstable crack growth.

FIG. 10 Determination of Percent Shear Fracture

each energy level. Except being limited to only two energy levels (by availability of reference specimens), Practice E 691 was followed for the design and analysis of the data, the details

are given in ASTM Research Report NO. RR:E28-1014.⁷

11.2 Precision—The Precision information given below (in units of J and ft-lbf) is for the average CVN absorbed energy of five test determinations at each laboratory for each material.

Material	Low Energy		High Energy	
	J	ft-lbf	J	ft-lbf
Absorbed Energy	15.9	11.7	96.2	71.0
95 % Repeatability Limit	2.4	1.7	8.3	6.1
95 % Reproducibility Limits	2.7	2.0	9.2	6.8

The terms repeatability and reproducibility limit are used as defined in Practice E 177. The respective standard deviations among test results may be obtained by dividing the above limits by 2.8.

11.3 Bias—Bias cannot be defined for CVN absorbed energy. The physical simplicity of the pendulum design is complicated by complex energy loss mechanisms within the machine and the specimen. Therefore, there is no absolute standard to which the measured values can be compared.

12. Keywords

12.1 charpy test; fracture appearance; Izod test; impact test; notched specimens; pendulum machine

⁷ Supporting data have been filed at ASTM Headquarters and may be obtained by requesting Research Report E28-1014.

(Mandatory Information)

A1. GENERAL REQUIREMENTS FOR IMPACT MACHINES

A1.1 *The machine frame* shall be equipped with a bubble level or a machined surface suitable for establishing levelness of the axis of pendulum bearings or, alternatively, the levelness of the axis of rotation of the pendulum may be measured directly. The machine shall be level to within 3:1000 and securely bolted to a concrete floor not less than 150 mm (6 in.) thick or, when this is not practical, the machine shall be bolted to a foundation having a mass not less than 40 times that of the pendulum. The bolts shall be tightened as specified by the machine manufacturer.

A1.2 *A scale or digital display*, graduated in degrees or energy, on which readings can be estimated in increments of 0.25 % of the energy range or less shall be furnished for the machine.

A1.2.1 The scales and digital displays may be compensated for windage and pendulum friction. The error in the scale reading at any point shall not exceed 0.2 % of the range or 0.4 % of the reading, whichever is larger. (See A2.3.8.)

A1.3 *The total friction and windage losses* of the machine during the swing in the striking direction shall not exceed 0.75 % of the scale range capacity, and pendulum energy loss from friction in the indicating mechanism shall not exceed 0.25 % of scale range capacity. See A2.3.8 for friction and windage loss calculations.

A1.4 *The position of the pendulum*, when hanging freely, shall be such that the striker is within 2.5 mm (0.10 in.) from the test specimen. When the indicator has been positioned to read zero energy in a free swing, it shall read within 0.2 % of scale range when the striker of the pendulum is held against the test specimen. The plane of swing of the pendulum shall be perpendicular to the transverse axis of the Charpy specimen anvils or Izod vise within 3:1000.

A1.5 *Transverse play of the pendulum* at the striker shall not exceed 0.75 mm (0.030 in.) under a transverse force of 4 % of the effective weight of the pendulum applied at the center of strike. Radial play of the pendulum bearings shall not exceed 0.075 mm (0.003 in.).

A1.6 *The impact velocity* (tangential velocity) of the pendulum at the center of the strike shall not be less than 3 nor more than 6 m/s (not less than 10 nor more than 20 ft/s).

A1.7 *The height of the center of strike* in the latched position, above its free hanging position, shall be within 0.4 % of the range capacity divided by the supporting force, mea-

sured as described in A2.3.5.1 If windage and friction are compensated for by increasing the height of drop, the height of drop may be increased by not more than 1 %.

A1.8 *The mechanism for releasing the pendulum* from its initial position shall operate freely and permit release of the pendulum without initial impulse, retardation, or side vibration. If the same lever used to release the pendulum is also used to engage the brake, means shall be provided for preventing the brake from being accidentally engaged.

A1.9 *Specimen clearance* is needed to ensure satisfactory results when testing materials of different strengths and compositions. The test specimen shall exit the machine with a minimum of interference. Pendulums used on Charpy machines are of three basic designs, as shown in Fig. A1.1.

A1.9.1 When using a C-type pendulum or a compound pendulum, the broken specimen will not rebound into the pendulum and slow it down if the clearance at the end of the specimen is at least 13 mm (0.5 in.) or if the specimen is deflected out of the machine by some arrangement such as that shown in Fig. A1.1.

A1.9.2 When using the U-type pendulum, means shall be provided to prevent the broken specimen from rebounding against the pendulum (see Fig. A1.1). In most U-type pendulum machines, steel shrouds should be designed and installed to the following requirements: (a) have a thickness of approximately 1.5 mm (0.06 in.), (b) have a minimum hardness of 45 HRC, (c) have a radius of less than 1.5 mm (0.06 in.) at the underside corners, and (d) be so positioned that the clearance between them and the pendulum overhang (both top and sides) does not exceed 1.5 mm (0.06 in.).

NOTE A1.1—In machines where the opening within the pendulum permits clearance between the ends of a specimen (resting on the anvil supports) and the shrouds, and this clearance is at least 13 mm (0.5 in.), the requirements (a) and (d) need not apply.

A1.10 *Charpy Apparatus:*

A1.10.1 Means shall be provided (see Fig. A1.2) to locate and support the test specimen against two anvil blocks in such a position that the center of the notch can be located within 0.25 mm (0.010 in.) of the midpoint between the anvils (see 8.3.2).

A1.10.2 The supports and striker shall be of the forms and dimensions shown in Fig. A1.2. Other dimensions of the pendulum and supports should be such as to minimize interference between the pendulum and broken specimens.

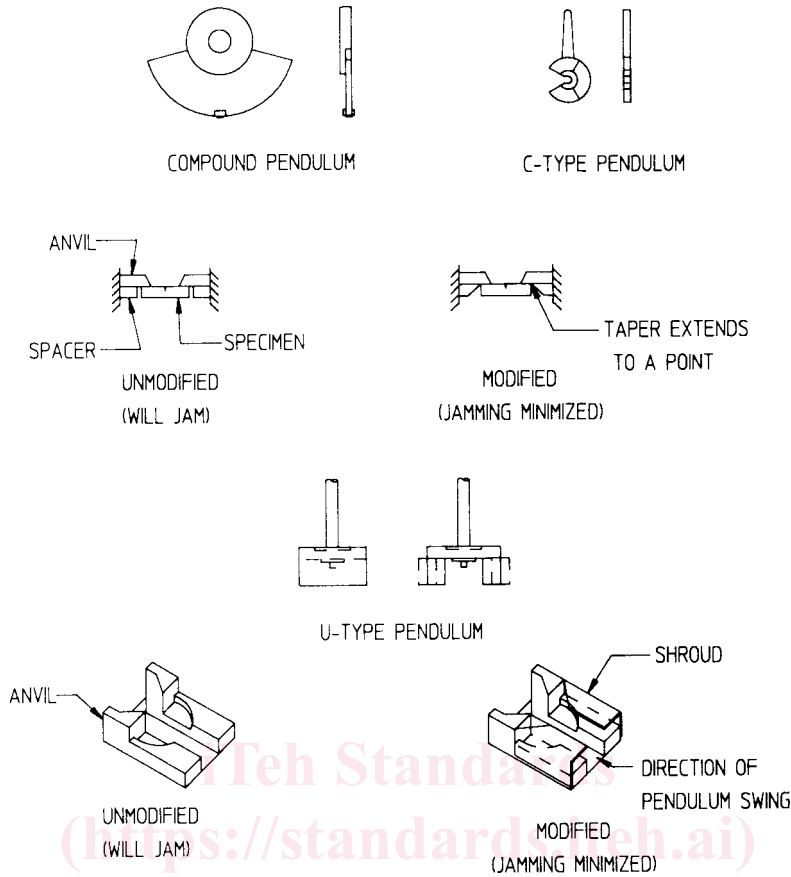

FIG. A1.1 Typical Pendulums and Anvils for Charpy Machines, Shown with Modifications to Minimize Jamming

A1.10.3 The center line of the striker shall advance in the plane that is within 0.40 mm (0.016 in.) of the midpoint between the supporting edges of the specimen anvils. The striker shall be perpendicular to the longitudinal axis of the specimen within 5:1000. The striker shall be parallel within 1:1000 to the face of a perfectly square test specimen held against the anvil.

A1.11 Izod Apparatus:

A1.11.1 Means shall be provided (see Fig. A1.3) for clamping the specimen in such a position that the face of the specimen is parallel to the striker within 1:1000. The edges of the clamping surfaces shall be sharp angles of $90 \pm 1^\circ$ with

radii less than 0.40 mm (0.016 in.). The clamping surfaces shall be smooth with a 2- μm (63- $\mu\text{in.}$) finish or better, and shall clamp the specimen firmly at the notch with the clamping force applied in the direction of impact. For rectangular specimens, the clamping surfaces shall be flat and parallel within 0.025 mm (0.001 in.). For cylindrical specimens, the clamping surfaces shall be contoured to match the specimen and each surface shall contact a minimum of $\pi/2$ rad (90°) of the specimen circumference.

A1.11.2 The dimensions of the striker and its position relative to the specimen clamps shall be as shown in Fig. A1.3.