



# Standard Test Method for Dynamic Young's Modulus, Shear Modulus, and Poisson's Ratio by Sonic Resonance<sup>1</sup>

This standard is issued under the fixed designation E 1875; the number immediately following the designation indicates the year of original adoption or, in the case of revision, the year of last revision. A number in parentheses indicates the year of last reappraisal. A superscript epsilon ( $\epsilon$ ) indicates an editorial change since the last revision or reappraisal.

## 1. Scope

1.1 This test method covers the determination of the dynamic elastic properties of elastic materials. Specimens of these materials possess specific mechanical resonant frequencies that are determined by the elastic modulus, mass, and geometry of the test specimen. Therefore, the dynamic elastic properties of a material can be computed if the geometry, mass, and mechanical resonant frequencies of a suitable test specimen of that material can be measured. Dynamic Young's modulus is determined using the resonant frequency in the flexural mode of vibration. The dynamic shear modulus, or modulus of rigidity, is found using torsional resonant vibrations. Dynamic Young's modulus and dynamic shear modulus are used to compute Poisson's ratio.

1.2 This test method is specifically appropriate for materials that are elastic, homogeneous, and isotropic (1).<sup>2</sup> Materials of a composite character (particulate, whisker, or fiber reinforced) may be tested by this test method with the understanding that the character (volume fraction, size, morphology, distribution, orientation, elastic properties, and interfacial bonding) of the reinforcement in the test specimen will have a direct effect on the elastic properties. These reinforcement effects must be considered in interpreting the test results for composites. This test method is not satisfactory for specimens that have cracks or voids that are major discontinuities in the specimen. Neither is the test method satisfactory when these materials cannot be fabricated in a uniform rectangular or circular cross section.

1.3 A high-temperature furnace and cryogenic cabinet are described for measuring the dynamic elastic moduli as a function of temperature from  $-195$  to  $1200^{\circ}\text{C}$ .

1.4 Modification of this test method for use in quality control is possible. A range of acceptable resonant frequencies is determined for a specimen with a particular geometry and mass. Any specimen with a frequency response falling outside this frequency range is rejected. The actual modulus of each specimen need not be determined as long as the limits of the selected frequency range are known to include the resonant frequency that the specimen must possess if its geometry and

mass are within specified tolerances.

1.5 There are material specific ASTM standards that cover the determination of resonance frequencies and elastic properties of specific materials by sonic resonance or by impulse excitation of vibration. Test Methods C 215, C 623, C 747, C 848, C 1198, and C 1259 may differ from this test method in several areas (for example; sample size, dimensional tolerances, sample preparation). The testing of these materials shall be done in compliance with these material specific standards. Where possible, the procedures, sample specifications, and calculations are consistent with these test methods.

1.6 The values stated in SI units are regarded as the standard.

1.7 *This standard does not purport to address all of the safety concerns, if any, associated with its use. It is the responsibility of the user of this standard to establish appropriate safety and health practices and determine the applicability of regulatory limitations prior to use.*

## 2. Referenced Documents

### 2.1 ASTM Standards:

- C 215 Test Method for Fundamental Transverse, Longitudinal and Torsional Frequencies of Concrete Specimens<sup>2</sup>
- C 623 Test Method for Young's Modulus, Shear Modulus, and Poisson's Ratio for Glass and Glass-Ceramics by Resonance<sup>3</sup>
- C 747 Test Method for Moduli of Elasticity and Fundamental Frequencies of Carbon and Graphite Materials by Sonic Resonance<sup>4</sup>
- C 848 Test Method for Dynamic Young's Modulus, Shear Modulus, and Poisson's Ratio for Ceramic Whitewares by Resonance<sup>3</sup>
- C 1198 Test Method for Dynamic Young's Modulus, Shear Modulus and Poisson's Ratio for Advanced Ceramics by Sonic Resonance<sup>4</sup>
- C 1259 Test Method for Dynamic Young's Modulus, Shear Modulus and Poisson's Ratio for Advanced Ceramics by Impulse Excitation of Vibration<sup>4</sup>
- E 6 Terminology Relating to Methods of Mechanical Testing<sup>5</sup>

<sup>1</sup> This test method is under the jurisdiction of ASTM Committee E28 on Mechanical Testing and is the direct responsibility of Subcommittee E28.03 on Elastic Properties.

Current edition approved Oct. 10, 2000. Published January 2001.

Originally published as E1875-97. Last previous edition E1875-97.

<sup>2</sup> *Annual Book of ASTM Standards*, Vol 04.02.

<sup>3</sup> *Annual Book of ASTM Standards*, Vol 15.02.

<sup>4</sup> *Annual Book of ASTM Standards*, Vol 15.01.

<sup>5</sup> *Annual Book of ASTM Standards*, Vol 03.01.

E 177 Practice for Use of the Terms Precision and Bias in ASTM Test Methods<sup>6</sup>

### 3. Terminology

#### 3.1 Definitions:

3.1.1 *dynamic mechanical measurement, n*—a technique in which either the modulus or damping, or both, of a substance under oscillatory applied force or displacement is measured as a function of temperature, frequency, or time, or a combination thereof.

3.1.2 *elastic limit* [FL<sup>-2</sup>], *n*—the greatest stress that a material is capable of sustaining without permanent strain remaining upon complete release of the stress. (E 6)

3.1.3 *elastic modulus* [FL<sup>-2</sup>], *n*—the ratio of stress to strain below the proportional limit. (E 6)

3.1.4 *Poisson's ratio* ( $\mu$ ) [nd], *n*—the absolute value of the ratio of transverse strain to the corresponding axial strain resulting from uniformly distributed axial stress below the proportional limit of the material.

3.1.4.1 *Discussion*—In isotropic materials Young's modulus ( $E$ ), shear modulus ( $G$ ), and Poisson's ratio ( $\mu$ ) are related by the following equation:

$$\mu = (E/2G) - 1 \quad (1)$$

(E 6)

3.1.5 *proportional limit* [FL<sup>-2</sup>], *n*—the greatest stress that a material is capable of sustaining without deviation from proportionality of stress to strain (Hooke's law). (E 6)

3.1.6 *shear modulus* ( $G$ ) [FL<sup>-2</sup>], *n*—the elastic modulus in shear or torsion. Also called *modulus of rigidity* or *torsional modulus*.

3.1.7 *Young's modulus* ( $E$ ) [FL<sup>-2</sup>], *n*—the elastic modulus in tension or compression. (E 6)

#### 3.2 Definitions of Terms Specific to This Standard:

3.2.1 *anti-nodes, n*—an unconstrained slender rod or bar in resonance contains two or more locations that have local maximum displacements, called anti-nodes. For the fundamental flexure resonance, the anti-nodes are located at the two ends and the center of the specimen.

3.2.2 *elastic, adj*—the property of a material such that an application of stress within the elastic limit of that material making up the body being stressed will cause an instantaneous and uniform deformation, that will be eliminated upon removal of the stress, with the body returning instantly to its original size and shape without energy loss. Most elastic materials conform to this definition well enough to make this resonance test valid.

3.2.3 *flexural vibrations, n*—when the oscillations in a slender rod or bar are in a vertical plane normal to the length dimension, the vibrations are said to be in the flexural mode.

3.2.4 *homogeneous, adj*—the condition of a specimen such that the composition and density are uniform, such that any smaller specimen taken from the original is representative of the whole. Practically, as long as the geometrical dimensions of the test specimen are large with respect to the size of individual grains, crystals, or components, the body can be considered homogeneous.

3.2.5 *isotropic, adj*—the condition of a specimen such that the values of the elastic properties are the same in all directions in the material. Materials are considered isotropic on a macroscopic scale, if they are homogeneous and there is a random distribution and orientation of phases, crystallites, and components.

3.2.6 *nodes, n*—slender rod or bar in resonance contains one or more locations having a constant zero displacement, called nodes. For the fundamental flexural resonance, the nodes are located at 0.224  $L$  from each end, where  $L$  is the length of the specimen.

3.2.7 *resonance, n*—slender rod or bar driven into one of the modes of vibration described in 3.2.3 or 3.2.9 is said to be in resonance when the imposed frequency is such that the resultant displacements for a given amount of driving force are at a maximum. The resonant frequencies are natural vibration frequencies that are determined by the elastic modulus, mass, and dimensions of the test specimen.

3.2.8 *slender rod or bar, n*—in dynamic elastic property testing, a specimen whose ratio of length to minimum cross-sectional dimension is at least five and preferably in the range from 20 to 25.

3.2.9 *torsional vibrations, n*—when the oscillations in each cross-sectional plane of a slender rod or bar are such that the plane twists around the length dimension axis, the vibrations are said to be in the torsional mode.

### 4. Summary of Test Method

4.1 This test method measures the resonant frequencies of test specimens of suitable geometry by exciting them at continuously variable frequencies. Mechanical excitation of the bars is provided through the use of a transducer that transforms a cyclic electrical signal into a cyclic mechanical force on the specimen. A second transducer senses the resulting mechanical vibrations of the specimen and transforms them into an electrical signal. The amplitude and frequency of the signal are measured by an oscilloscope or other means to detect resonance. The resonant frequencies, dimensions, and mass of the specimen are used to calculate dynamic Young's modulus and dynamic shear modulus.

### 5. Significance and Use

5.1 This test method has advantages in certain respects over the use of static loading systems for measuring moduli.

5.1.1 This test method is nondestructive in nature. Only minute stresses are applied to the specimen, thus minimizing the possibility of fracture.

5.1.2 The period of time during which measurement stress is applied and removed is of the order of hundreds of microseconds. With this test method it is feasible to perform measurements at high temperatures, where delayed elastic and creep effects would invalidate modulus measurements calculated from static loading.

5.2 This test method is suitable for detecting whether a material meets specifications, if cognizance is given to one important fact in materials are often sensitive to thermal history. Therefore, the thermal history of a test specimen must be considered in comparing experimental values of moduli to reference or standard values. Specimen descriptions should

<sup>6</sup> Annual Book of ASTM Standards, Vol 14.02.

include any specific thermal treatments that the specimens have received.

**6. Apparatus**

6.1 The test apparatus is shown in Fig. 1. It consists of a variable-frequency audio oscillator, used to generate a sinusoidal voltage, and a power amplifier and suitable transducer to convert the electrical signal to a mechanical driving vibration. A frequency meter (preferably digital) monitors the audio oscillator output to provide an accurate frequency determination. A suitable suspension-coupling system supports the test specimen. Another transducer acts to detect mechanical vibration in the specimen and to convert it into an electrical signal that is passed through an amplifier and displayed on an indicating meter. The meter may be a voltmeter, microammeter, or oscilloscope. An oscilloscope is recommended because it enables the operator to positively identify resonances, including higher order harmonics, by Lissajous figure analysis. If a Lissajous figure is desired, the output of the oscillator is also coupled to the horizontal plates of the oscilloscope. If temperature-dependent data are desired, a suitable furnace or cryogenic chamber is used. Details of the equipment are as follows:

6.2 *Audio Oscillator*, having a continuously variable frequency output from about 100 Hz to at least 30 kHz. Frequency drift shall not exceed 1 Hz/min for any given setting.

6.3 *Audio Amplifier*, having a power output sufficient to ensure that the type of transducer used can excite any specimen the mass of which falls within a specified range.

6.4 *Transducers*— Two are required; one used as a driver may be a speaker of the tweeter type or a magnetic cutting head or other similar device depending on the type of coupling chosen for use between the transducer and the specimen. The other transducer, used as a detector, may be a crystal or magnetic reluctance type of phonograph cartridge. A capacitive pickup may be used if desired. An electromagnetic coupling system with an attached metal foil may also be used, with due consideration for effects of the foil on the natural vibration of the test bar. The frequency response of the transducer across the frequency range of interest shall have at least a 6.5 kHz bandwidth before -3 dB power loss occurs.

6.5 *Power Amplifier*, in the detector circuit shall be impedance matched with the type of detector transducer selected and

shall serve as a prescope amplifier.

6.6 *Cathode-Ray Oscilloscope*, any model suitable for general laboratory work.

6.7 *Frequency Counter*, preferably digital, shall be able to measure frequencies to within  $\pm 1$  Hz.

6.8 *Furnace*—If data at an elevated temperature are desired, a furnace shall be used that is capable of controlled heating and cooling. It shall have a specimen zone large enough for the specimen to be uniform in temperature within  $\pm 5^\circ\text{C}$  along its length through the range of temperatures encountered in testing. It is recommended that an independent thermocouple be placed in close proximity to (within 5 mm), but not touching, the center of the specimen to accurately measure temperature during heating and cooling.

6.9 *Cryogenic Chamber*—For data at cryogenic temperatures, any chamber shall suffice that shall be capable of controlled heating/cooling, frost-free and uniform in temperature within  $\pm 5^\circ\text{C}$  over the length of the specimen at any selected temperature. A suitable cryogenic chamber is shown in Fig. 2 (2). It is recommended that an independent thermocouple be placed in close proximity to (within 5 mm), but not touching, the center of the specimen to accurately measure temperature during heating and cooling.

6.10 *Specimen Suspension*—Any method of specimen suspension shall be used that is adequate for the temperatures encountered in testing and that allows the specimen to vibrate without significant restriction. Thread suspension is the system of choice for cryogenic and high-temperature testing. (See Fig. 1 and Fig. 3.) Common cotton thread, silica-glass fiber thread, oxidation-resistant nickel (or platinum) alloy wire, or platinum wire may be used. If metal wire suspension is used in the furnace, coupling characteristics will be improved if, outside the temperature zone, the wire is coupled to cotton thread, and

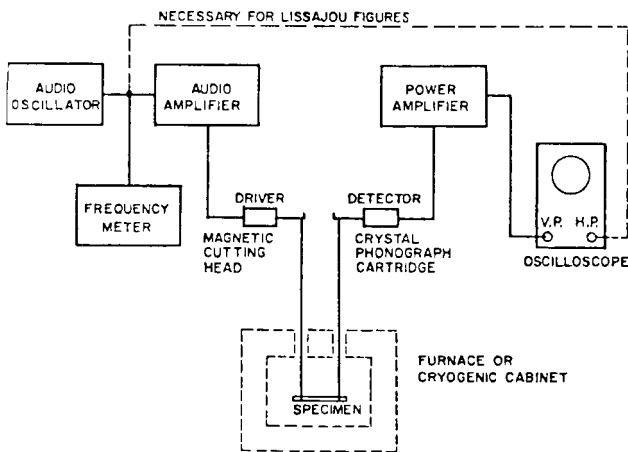
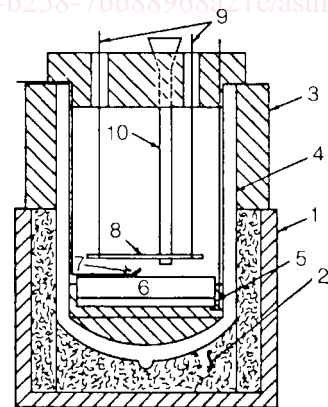

FIG. 1 Block Diagram of a Typical Test Apparatus



NOTE 1—Legend:

- 1 = Cylindrical glass jar
- 2 = Glass wool
- 3 = Plastic foam
- 4 = Vacuum jar
- 5 = Heater disk
- 6 = Copper plate
- 7 = Thermocouple
- 8 = Sample
- 9 = Suspension wires
- 10 = Fill port for liquid

FIG. 2 Detail Drawing of a Typical Cryogenic Chamber

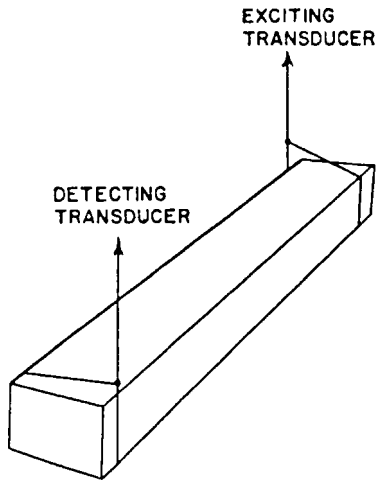

**FIG. 3 Specimen Positioned for Measurement of Flexural and Torsional Resonant Frequencies Using Thread or Wire Suspension**

the thread is coupled to the transducer. The specimen should be initially suspended at distances of approximately  $0.1 L$  from each end. The specimen should not be suspended at its fundamental flexural node locations ( $0.224 L$  from each end). The suspension point distances can be adjusted experimentally to maximize the vibrational deflection and resulting signal. For torsional vibration, the axes of suspension have to be off-center from the longitudinal axis of the specimen (shown in Fig. 3).

6.11 *Specimen Supports*—If the specimen is supported on direct contact supports, the supports shall permit the specimen to oscillate without significant restriction in the desired mode. This is accomplished for flexural modes by supporting the specimen at its transverse fundamental node locations ( $0.224 L$  from each end). In torsional modes the specimen should be supported at its center point. The supports should have minimal area in contact with the specimen and shall be cork, rubber, or similar material. In order to properly identify resonant frequencies, the transducers should be movable along the total specimen length and width. (See Fig. 4.) The transducer contact pressure should be consistent with good response and minimal interference with the free vibration of the specimen.

**7. Test Specimen**

7.1 Prepare the specimens so that they are either rectangular or circular in cross section. Either geometry can be used to

measure both dynamic Young’s modulus and dynamic shear modulus. However, experimental difficulties in obtaining torsional resonant frequencies for a cylindrical specimen usually preclude its use in determining shear modulus, although the equations for computing shear modulus with a cylindrical specimen are both simpler and more accurate than those used with a rectangular bar.

7.2 Resonant frequencies for a given specimen are functions of the bar dimensions as well as its mass and moduli; therefore, dimensions should be selected with this relationship in mind. Make selection of size so that, for an estimated modulus, the resonant frequencies measured will fall within the range of frequency response of the transducers used. A slender rod with a ratio of length to minimum cross-sectional dimension greater than 5 and approximately 25 is preferred for ease in calculation. For shear modulus measurements of rectangular bars, a ratio of width to thickness of five is recommended for minimizing experimental difficulties.

7.2.1 These specimen sizes should produce a fundamental flexural resonant frequency in the range from 1000 to 10 000 Hz and a fundamental torsional resonant frequency in the range from 10 000 to 30 000 Hz. Specimens shall have a minimum mass of 5 g to avoid coupling effects; any size of specimen that has a suitable length-to-cross section ratio in terms of frequency response and meets the mass minimum may be used. Maximum specimen size and mass are determined primarily by the power of the test system and physical space capabilities.

7.3 All surfaces on the rectangular specimen shall be flat. Opposite surfaces across the length, thickness, and width shall be parallel to within 0.1 %. The cylindrical specimen shall be round and constant in diameter to within 0.1 %.

7.4 Specimen mass shall be determined to within 0.1 %

7.5 Specimen length shall be measured to within 0.1 %. The thickness and width of the rectangular specimen shall be measured to within 0.1 % at three locations and an average determined. The diameter of the cylindrical specimen shall be measured to within 0.1 % at three locations and an average determined.

7.6 Table 1 illustrates how uncertainties in the measured parameters influence the calculated modulus. It shows that calculations are most sensitive to error in the measurement of the thickness. Special care must be taken when measuring the thickness of samples with a thickness of less than 3 mm.

**8. Procedure**

8.1 *Procedure A—Room-Temperature Testing:*

8.1.1 Switch on all electrical equipment and allow to stabilize in accordance with the manufacturer’s recommendations. Suspend or support the specimen properly (see Fig. 3 and

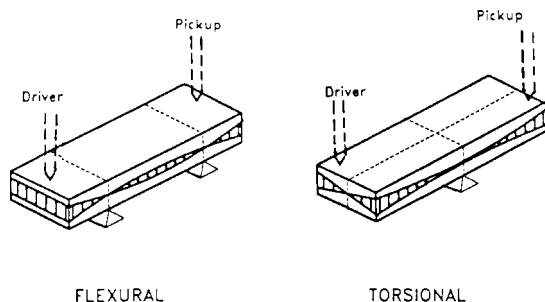

**FIG. 4 Specimen Positioned for Measurement of Flexural and Torsional Resonant Frequencies Using Direct Support and Direct Contact Transducers**

**TABLE 1 Effects of Variable Error on Modulus Calculation**

Variable	Measurement Error	Variable Exponent in Modulus Equation	Calculation Error
Frequency ( $f$ )	0.1 %	$f^2$	0.2 %
Length ( $L$ )	0.1 %	$L^3$	0.3 %
Mass ( $m$ )	0.1 %	$m$	0.1 %
Width ( $b$ )	0.1 %	$b^{-1}$	0.1 %
Thickness ( $t$ )	0.1 %	$t^{-3}$	0.3 %
Diameter ( $D$ )	0.1 %	$D^{-4}$	0.4 %