



Standard Test Method for Microindentation Hardness of Materials¹

This standard is issued under the fixed designation E 384; the number immediately following the designation indicates the year of original adoption or, in the case of revision, the year of last revision. A number in parentheses indicates the year of last reapproval. A superscript epsilon (ϵ) indicates an editorial change since the last revision or reapproval.

This standard has been approved for use by agencies of the Department of Defense.

1. Scope

1.1 This test method covers determination of the microindentation hardness of materials, the verification of microindentation hardness testing machines, and the calibration of standardized test blocks.

1.2 This test method covers microindentation tests made with Knoop and Vickers indenters under test forces in the range from 1 to 1000 gf (9.8×10^{-3} to 9.8 N).

1.3 This test method includes an analysis of the possible sources of errors that can occur during microindentation testing and how these factors affect the accuracy, repeatability, and reproducibility of test results.

NOTE 1—While Committee E-4 is primarily concerned with metals, the test procedures described are applicable to other materials.

1.4 *This standard does not purport to address all of the safety concerns, if any, associated with its use. It is the responsibility of the user of this standard to establish appropriate safety and health practices and determine the applicability of regulatory limitations prior to use.*

2. Referenced Documents

2.1 ASTM Standards:

C 1326 Test Method for Knoop Indentation Hardness of Advanced Ceramics²

C 1327 Test Method for Vickers Indentation Hardness of Advanced Ceramics²

E 3 Methods of Preparation of Metallographic Specimens³

E 7 Terminology Relating to Metallography³

E 122 Practice for Choice of Sample Size to Estimate the Average Quality for a Lot or Process⁴

E 140 Test Method for Hardness Conversion Tables for Metals³

E 175 Terminology of Microscopy⁵

E 691 Practice for Conducting an Interlaboratory Study to Determine the Precision of a Test Method⁴

¹ This test method is under the jurisdiction of ASTM Committee E-4 on Metallography and is the direct responsibility of Subcommittee E04.05 on Microhardness.

Current edition approved Nov. 10, 1999. Published March 2000. Originally published as E 384 – 69. Last previous edition E 384 – 89.

² Annual Book of ASTM Standards, Vol 15.01.

³ Annual Book of ASTM Standards, Vol 03.01.

⁴ Annual Book of ASTM Standards, Vol 14.02.

⁵ Annual Book of ASTM Standards, Vol 14.01.

E 766 Practice for Calibrating the Magnification of a Scanning Electron Microscope³

3. Terminology

3.1 *Definitions*—For definitions of terms used in this test method, see Terminology E 7.

3.2 Definitions of Terms Specific to This Standard:

3.2.1 *calibrating, v*—determining the values of the significant parameters by comparison with values indicated by a reference instrument or by a set of reference standards.

3.2.2 *Knoop hardness number, HK, n*—an expression of hardness obtained by dividing the force applied to the Knoop indenter by the projected area of the permanent impression made by the indenter.

3.2.3 *Knoop indenter, n*—a rhombic-based pyramidal-shaped diamond indenter with edge angles of $\angle A = 172^\circ 30'$ and $\angle B = 130^\circ 0'$ (see Fig. 1).

3.2.4 *microindentation hardness test, n*—a hardness test using a calibrated machine to force a diamond indenter of specific geometry into the surface of the material being evaluated, in which the test forces range from 1 to 1000 gf (9.8×10^{-3} to 9.8 N), and the indentation diagonal, or diagonals are measured with a light microscope after load removal; for any microindentation hardness test, it is assumed that the indentation does not undergo elastic recovery after force removal.

NOTE 2—Use of the term microhardness should be avoided because it implies that the hardness, rather than the force or the indentation size, is very low.

3.2.5 *verifying, v*—checking or testing the instrument to assure conformance with the specification.

3.2.6 *Vickers hardness number, HV, n*—an expression of hardness obtained by dividing the force applied to a Vickers indenter by the surface area of the permanent impression made by the indenter.

3.2.7 *Vickers indenter, n*—a square-based pyramidal-shaped diamond indenter with face angles of 136° (see Fig. 2).

3.3 *Formulae*—The formulae presented in 3.3.1-3.3.4 for calculating microindentation hardness are based upon an ideal tester. The measured value of the microindentation hardness of a material is subjected to several sources of errors. Based on Eq 1-9, variations in the applied force, geometrical variations between diamond indenters, and human errors in measuring indentation lengths can affect the calculated material hardness. The amount of error each of these parameters has on the

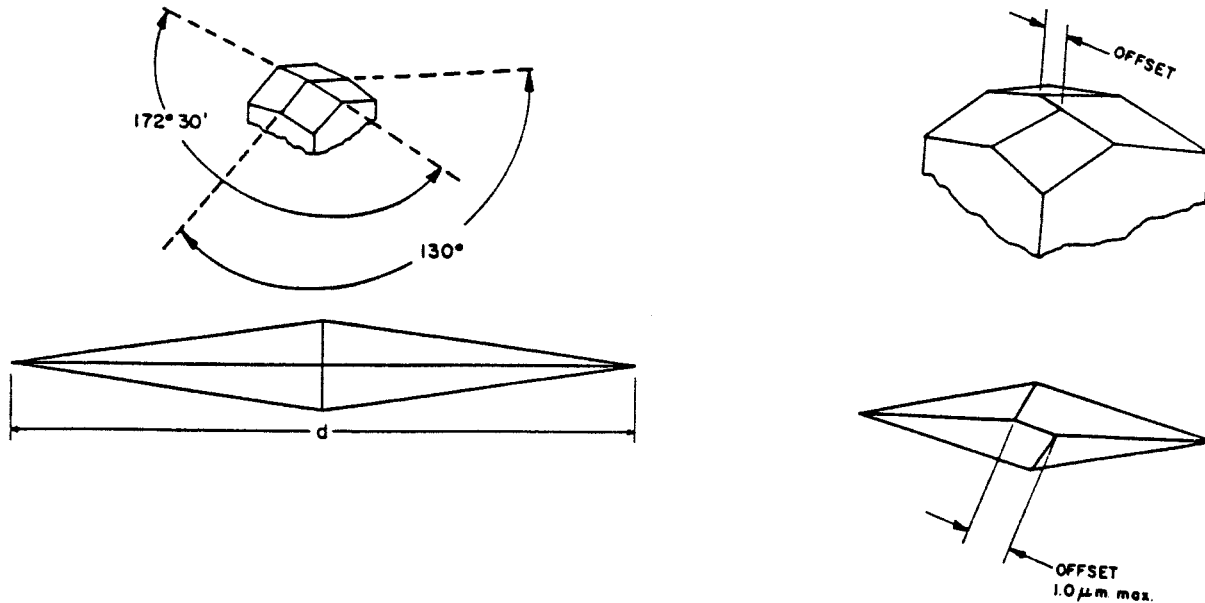

FIG. 1 Knoop Indenter

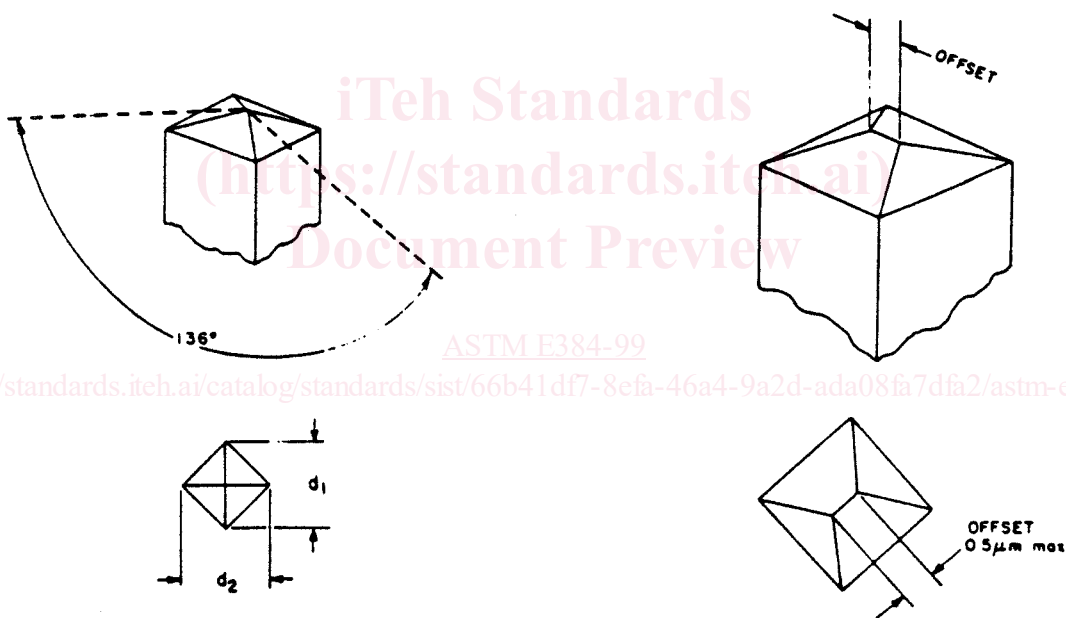

FIG. 2 Vickers Indenter

calculated value of a microindentation measurement is discussed in Section 10.

3.3.1 For Knoop hardness tests, in practice, test loads are in grams-force and indentation diagonals are in micrometres. The Knoop hardness number is calculated using the following:

$$HK = 1.000 \times 10^3 \times (P/A_p) = 1.000 \times 10^3 \times P/(c_p \times d^2) \quad (1)$$

or

$$HK = 14229 \times P/d^2 \quad (2)$$

$$c_p = \frac{\tan\left(\frac{\angle B}{2}\right)}{2 \tan\left(\frac{\angle A}{2}\right)} \quad (3)$$

where:

- P = force, gf,
- d = length of long diagonal, μm ,
- A_p = projected area of indentation, μm^2 ,
- $\angle A$ = included longitudinal edge angle, $172^\circ 30'$,
- $\angle B$ = included transverse edge angle, $130^\circ 0'$ (see Fig. 1), and
- c_p = indenter constant relating projected area of the indentation to the square of the length of the long diagonal, ideally 0.07028.

NOTE 3—HK values for a 1-gf (9.8×10^{-3} N) test are contained in Appendix X5. To obtain HK values when other test forces are employed, multiply the HK value from Table X5.1 for the d value by the actual test force, g.

3.3.2 The Knoop hardness, kgf/mm² is determined as follows:

$$HK = 14.229 \times P_1/d_1^2 \quad (4)$$

where:

P_1 = force, kgf, and

d_1 = length of long diagonal, mm.

3.3.3 The Knoop hardness reported with units of GPa is determined as follows:

$$HK = 0.014229 \times P_2/d_2^2 \quad (5)$$

where:

P_2 = force, N, and

d_2 = length of the long diagonal of the indentation, mm.

3.3.4 For the Vickers hardness test, in practice, test loads are in grams-force and indentation diagonals are in micrometres. The Vickers hardness number is calculated as follows:

$$HV = 1.000 \times 10^3 \times P/A_s = 2.000 \times 10^3 \times P \sin(\alpha/2)/d^2 \quad (6)$$

or

$$HV = 1854.4 \times P/d^2 \quad (7)$$

where:

P = force, gf,

A_s = surface area of the indentation, μm^2 ,

d = mean diagonal length of the indentation, μm , and

α = face angle of the indenter, 136° 0' (see Fig. 2).

NOTE 4—HV numbers for a 1-gf (9.8×10^{-3} N) test load are contained in Appendix X5. To obtain HV values when other test forces are employed, multiply the HV value from Table X5.2 for the d value by the actual test force, g.

3.3.5 The Vickers hardness, kgf/mm² is determined as follows:

$$HV = 1.8544 \times P_1/d_1^2 \quad (8)$$

where:

P_1 = force, kgf, and

d_1 = length of long diagonal, mm.

3.3.6 The Vickers hardness reported with units of GPa is determined as follows:

$$HV = 0.0018544 \times P_2/d_2^2 \quad (9)$$

where:

P_2 = force, N, and

d_2 = length of the long diagonal of the indentation, mm.

4. Summary of Test Method

4.1 In this test method, a hardness number is determined based on the formation of a very small indentation by application of a relatively low force, in comparison to ordinary indentation hardness tests.

4.2 A Knoop or Vickers indenter, made from diamond of specific geometry is pressed into the test specimen surface under an applied force in the range of 1 to 1000 gf using a test machine specifically designed for such work.

4.3 The size of the indentation is measured using a light microscope equipped with a filar type eyepiece, or other type of measuring device (see Terminology E 175).

4.4 The Knoop hardness number is based upon the force

divided by the projected area of the indentation. The Vickers hardness number is based upon the force divided by the surface area of the indentation.

4.5 It is assumed that elastic recovery does not occur when the indenter is removed after the loading cycle, that is, it is assumed that the indentation retains the shape of the indenter after the force is removed. In Knoop testing, it is assumed that the ratio of the long diagonal to the short diagonal of the impression is the same (see 7.1.4) as for the indenter.

5. Significance and Use

5.1 Hardness tests have been found to be very useful for materials evaluation, quality control of manufacturing processes and research and development efforts. Hardness, although empirical in nature, can be correlated to tensile strength for many metals, and is an indicator of wear resistance and ductility.

5.2 Microindentation tests extend hardness testing to materials too thin or too small for macroindentation tests. Microindentation tests allow specific phases or constituents and regions or gradients too small for macroindentation testing to be evaluated.

5.3 Because the microindentation hardness will reveal hardness variations that may exist within a material, a single test value may not be representative of the bulk hardness.

6. Apparatus

6.1 *Test Machine*—The test machine must support the test specimen and control the movement of the indenter into the specimen under a preselected test force, and should have a light optical microscope to select the desired test location and to measure the size of the indentation produced by the test. The plane of the surface of the test specimen must be perpendicular to the axis of the indenter and the direction of the force application. The plane of the test surface of test specimen must be level in order to obtain usable information.

6.1.1 *Force Application*—The test machine shall be capable of applying the following forces:

6.1.1.1 The time from the initial application of the force until the full test force is reached shall not exceed 10 s.

6.1.1.2 The indenter shall contact the specimen at a velocity between 15 and 70 $\mu\text{m/s}$.

6.1.1.3 The full test force shall be applied for 10 to 15 s unless otherwise specified.

6.1.1.4 For some applications it may be necessary to apply the test force for longer times. In these instances the tolerance for the time of the applied force is ± 2 s.

6.1.2 *Vibration Control*—During the entire test cycle, the test machine should be protected from shock or vibration. To minimize vibrations, the operator should avoid contacting the machine in any manner during the entire test cycle.

6.2 *Vickers Indenter*—The Vickers indenter usually produces a geometrically similar indentation at all test forces. Except for tests at very low forces that produce indentations with diagonals smaller than about 25 μm , the hardness number will be essentially the same as produced by Vickers machines with test forces greater than 1 kgf, as long as the material being tested is reasonably homogeneous. For isotropic materials, the two diagonals of a Vickers indentation are equal in size.

6.2.1 The ideal Vickers indenter is a highly polished, pointed, square-based pyramidal diamond with face angles of $136^{\circ} 0'$. The effect that geometrical variations of these angles have on the measured values of Vickers hardness are discussed in Section 10.

6.2.2 The four faces of the Vickers indenter shall be equally inclined to the axis of the indenter (within $\pm 30'$) and shall meet at a sharp point. The line of junction between opposite faces (offset) shall be not more than $0.5 \mu\text{m}$ in length as shown in Fig. 2.

6.3 *Knoop Indenter*—The Knoop indenter does not produce a geometrically similar indentation as a function of test force. Consequently, the Knoop hardness will vary with test force. Due to its rhombic shape, the indentation depth is shallower for a Knoop indentation compared to a Vickers indentation under identical test conditions. The two diagonals of a Knoop indentation are markedly different. Ideally, the long diagonal is 7.114 times longer than the short diagonal, but this ratio is influenced by elastic recovery. Thus, the Knoop indenter is very useful for evaluating hardness gradients or thin coatings.

6.3.1 The Knoop indenter is a highly polished, pointed, rhombic-based, pyramidal diamond. The ideal included longitudinal edge angles are $172^{\circ} 30'$ and $130^{\circ} 0'$. The ideal indenter constant, c_p , is 0.07028. The effect that geometrical variations of these angles have on the measured values of Knoop hardness are discussed in Section 10.

6.3.2 The four faces of the Knoop indenter shall be equally inclined to the axis of the indenter (within $\pm 30'$) and shall meet at a sharp point. The line of junction between opposite faces (offset) shall be not more than $1.0 \mu\text{m}$ in length for indentations greater than $20 \mu\text{m}$ in length, as shown in Fig. 1. For shorter indentations the offset should be proportionately less.

6.3.3 Indenters should be examined periodically and replaced if they become worn, dulled, chipped, cracked or separated from the mounting material.

6.4 *Measuring Equipment*—The test machine's measuring device should report the diagonal lengths in $0.1 \mu\text{m}$ increments for indentations with diagonals from 1 to $200 \mu\text{m}$.

NOTE 5—This is the reported length and not the resolution of the system used for performing the measurements. As an example, if a length of $200 \mu\text{m}$ corresponds to 300 filar units or pixels, the corresponding calibration constant would be $200/300 = 0.66666667$. This value would be used to compute diagonal lengths, but the reported length would only be reported to the nearest $0.1 \mu\text{m}$.

6.4.1 The optical portion of the measuring device should have Köhler illumination (see Appendix X1).

6.4.2 To obtain maximum resolution, the measuring microscope should have adjustable illumination intensity, adjustable alignment and aperture and field diaphragms.

6.4.3 Magnifications should be provided so that the diagonal can be enlarged to greater than 25 % but less than 75 % of the field width.

7. Test Specimen

7.1 For optimum accuracy of measurement, the test should be performed on a flat specimen with a polished or otherwise suitably prepared surface. The surface must be free of any defects that could affect the indentation or the subsequent

measurement of the diagonals. Conducting tests on non-planar surfaces is not recommended. Results will be affected even in the case of the Knoop test where the radius of curvature is in the direction of the short diagonal.

7.1.1 In all tests, the indentation perimeter, and the indentation tips in particular, must be clearly defined in the microscope field of view.

7.1.2 The specimen surface should not be etched before making an indentation. Etched surfaces can obscure the edge of the indentation, making an accurate measurement of the size of the indentation difficult. However, when determining the microindentation hardness of an isolated phase or constituent, a light etch can be used to delineate the object of interest. The quality of the required surface finish can vary with the forces and magnifications used in microindentation hardness testing. The lighter the force and the smaller the indentation size, the more critical is the surface preparation. Some materials are more sensitive to preparation-induced damage than others.

7.1.3 Due to the small size of the indentations, special precautions must be taken during specimen preparation. It is well known that improper polishing can alter test results. Specimen preparation must remove any damage introduced during these steps, either due to excessive heating or cold work, for example.

7.1.4 Specimen preparation should be performed in accordance with Methods E 3.

7.2 In some instances, it is necessary to mount the specimen for convenience in preparation. When mounting is required, the specimen must be adequately supported by the mounting medium so that the specimen does not move during force application, that is, avoid the use of polymeric mounting compounds that creep under the indenter force.

8. Procedure

8.1 Turn on the illumination system and power for the tester.

8.2 Select the desired indenter. Refer to the manufacturer's instruction manual if it is necessary to change indenters. Occasionally clean the indenter with a cotton swab and alcohol. Avoid creating static charges during cleaning.

8.3 Place the specimen on the stage or in the stage clamps, so that the specimen surface is perpendicular to the indenter axis.

8.4 Focus the measuring microscope with a low power objective so that the specimen surface can be observed.

8.5 Adjust the light intensity and adjust the apertures for optimum resolution and contrast.

8.6 Select the area desired for hardness determination. Before applying the force, make a final focus using the measuring objective or the highest magnification objective available.

8.7 Adjust the tester so that the indenter is in the proper place for force application. Select the desired force.

8.8 Activate the tester so that the indenter is automatically lowered and makes contact with the specimen for the normally required time period. Then, remove the force either manually or automatically.

8.9 After the force is removed, switch to the measuring mode, and select the proper objective lens. Focus the image, adjust the light intensity if necessary, and adjust the apertures

for maximum resolution and contrast.

8.10 Examine the indentation for its position relative to the desired location and for its symmetry.

8.10.1 If the indentation did not occur at the desired spot, the tester is out of alignment. Consult the manufacturer's instruction manual for the proper procedure to produce alignment. Make another indentation and recheck the indentation location. Readjust and repeat as necessary.

8.10.2 For a Knoop indentation, if one half of the long diagonal is greater than 10 % longer than the other, or if both ends of the indentation are not in sharp focus, the test specimen surface may not be perpendicular to the indenter axis. Check the specimen alignment and make another test.

8.10.3 For a Vickers indentation, if one half of either diagonal is more than 5 % longer than the other half of that diagonal, or if the four corners of the indentation are not in sharp focus, the test surface may not be perpendicular to the indenter axis. Check the specimen alignment and make another test.

8.10.4 If the diagonal legs are unequal as described in 8.10.2 or 8.10.3, rotate the specimen 90° and make another indentation in an untested region. If the nonsymmetrical aspect of the indentations has rotated 90°, then the specimen surface is not perpendicular to the indenter axis. If the nonsymmetrical nature of the indentation remains in the same orientation, check the indenter for misalignment or damage.

8.10.5 Some materials may have nonsymmetrical indentations even if the indenter and the specimen surface are perfectly aligned. Tests on single crystals or on textured materials may produce such results. When this occurs, check

the alignment using a test specimen, such as a standard, known to produce uniformly shaped indentations.

8.10.6 Brittle materials such as ceramics may crack as a result of being indented. Specific details for testing ceramics are contained in Test Methods C 1326 and C 1327.

8.11 Measure the long diagonal of a Knoop indentation, or both diagonals of a Vickers indentation, in accordance with the manufacturer's instruction manual.

8.11.1 Determine the length of the long diagonal of a Knoop indentation or both diagonals of a Vickers indentation to within 0.1 μm (see 6.3). For the Vickers indentations, average the two diagonal length measurements.

8.12 Compute the Knoop or Vickers hardness number using the appropriate equation in Section 3 or Table X5.1 or Table X5.2, respectively. Table X5.1 and Table X5.2 show the Knoop or Vickers hardness for indentations with diagonal lengths from 1 to 200.9 μm using 1 gf. If the force was not 1 gf, multiply the value from Table X5.1 or Table X5.2 by the actual gram-force value to obtain the correct hardness number.

8.13 Generally, more than one indentation is made on a test specimen. Ensure that the spacing between indentations is large enough so that adjacent tests do not interfere with each other. The minimum recommended spacing between tests is illustrated in Fig. 3.

9. Report

9.1 Report the following information:

9.1.1 The test results, the number of tests, and, where appropriate, the mean and standard deviation of the tests,

9.1.2 Test force,

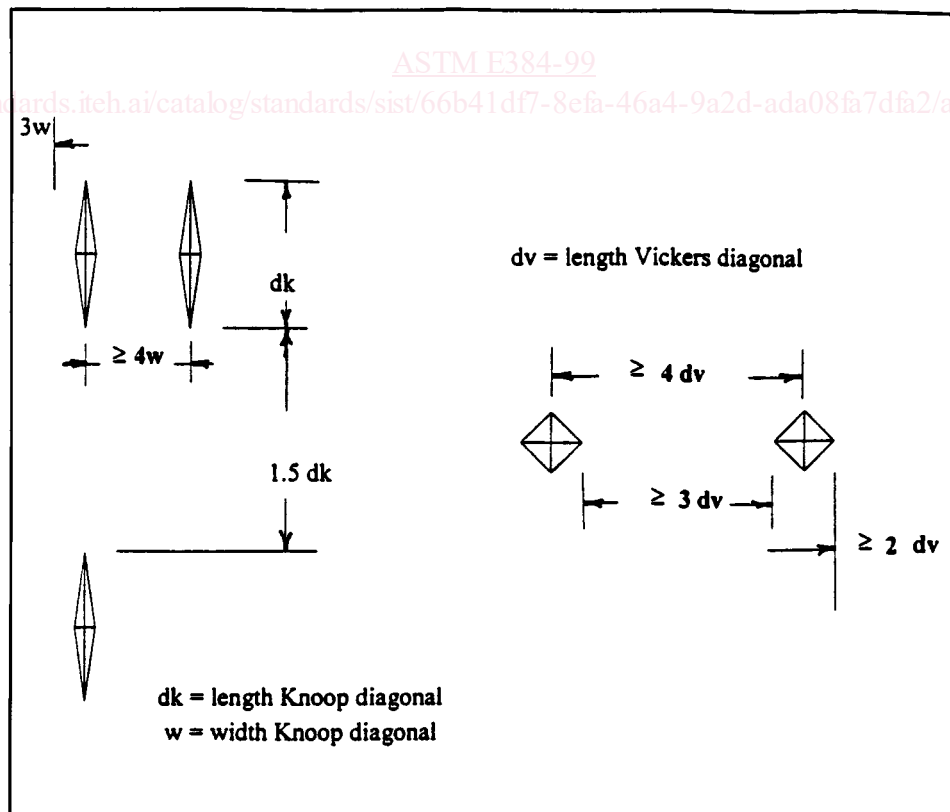

FIG. 3 Closest Permitted Spacing for Knoop and Vickers Indentations

9.1.3 Magnification, and

9.1.4 Any unusual conditions encountered during the test.

9.2 The symbols HK for Knoop hardness, and HV for Vickers hardness, shall be used with the reported numerical values.

9.2.1 The preferred method of reporting microindentation hardness test results in accordance with this standard is for the system of units consisting of force expressed as gram force. For example, if the Knoop hardness was 400 using a 100 gf force, it would be expressed as 400 HK 100 gf. For nonstandard dwell times, other than 10 to 15 s, the hardness would be reported as 400 HK 100 gf/22 s. In this case, 22 s would be the actual time of load application.

9.2.2 Alternative methods of denoting the microindentation hardness values can include 400 HK 0.1 in accordance with ISO for forces expressed in kilogram force, and 3.92 GPa for the SI system of units.

10. Precision and Bias ⁶

10.1 The precision and bias of microindentation hardness measurements depend on strict adherence to the stated test procedure and are influenced by instrumental and material factors and indentation measurement errors.

10.2 The consistency of agreement for repeated tests on the same material is dependent on the homogeneity of the material, reproducibility of the hardness tester, and consistent, careful measurement of the indents by a competent operator.

10.3 Instrumental factors that can affect test results include: accuracy of loading; inertia effects; speed of loading; vibrations; the angle of indentation; lateral movement of the indenter or specimen; indentation and indenter shape deviations.

10.3.1 Vibrations during indenting will produce larger indentations with the influence of vibrations becoming larger as the force decreases (1, 2).⁷

10.3.2 The angle between the indenter and specimen surface should be within 2° of perpendicular. Greater amounts of tilting produce nonuniform indentations and invalid test results.

10.4 Material factors that can affect test results include: specimen homogeneity, orientation or texture effects; improper specimen preparation; low specimen surface reflectivity; transparency of the specimen.

10.4.1 Residual deformation from mechanical polishing must be removed, particularly for low-force testing.

10.4.2 Distortion of the indentation shape due to either crystallographic or microstructural texture influences diagonal lengths and the validity of the calculated hardness.

10.4.3 Plastic deformation during indentation can produce ridging around the indentation periphery that will affect diagonal measurement accuracy.

10.4.4 Testing of etched surfaces, depending on the extent of etching, can produce results that are different from those obtained on unetched surfaces (1).

10.5 Measurement errors that can affect test results include:

inaccurate calibration of the measuring device; inadequate resolving power of the objective; insufficient magnification; operator bias in sizing the indentations; poor image quality; nonuniform illumination.

10.5.1 The accuracy of microindentation hardness testing is strongly influenced by the accuracy to which the indentations can be measured.

10.5.2 The error in measuring the diagonals increases as the numerical aperture of the measuring objective decreases (3, 4).

10.5.3 Bias is introduced if the operator consistently under-sizes or oversizes the indentations.

10.6 Some of the factors that affect test results produce systematic errors that influence all test results while others primarily influence low-force test results (5). Some of these problems occur continually, others may occur in an undefined, sporadic manner. Low force hardness tests are influenced by these factors to a greater extent than high force tests.

10.7 For both the Vickers and Knoop hardness tests, the calculated microindentation hardness is a function of three variables: force, indenter geometry and diagonal measurement. Total differentials of the equations used to calculate the microindentation hardness can be used to evaluate the effect variations in these parameters can cause.

10.7.1 *Vickers*—using Eq 6, the total differential for the Vickers hardness number is:

$$dV = \left(\frac{\partial V}{\partial P}\right) dP + \left(\frac{\partial V}{\partial d}\right) dd + \left(\frac{\partial V}{\partial \alpha}\right) d\alpha \quad (10)$$

and

$$\left(\frac{\partial V}{\partial P}\right) = 2 \times 10^3 \times d^2 \times \sin\left(\frac{\alpha}{2}\right) \quad (11)$$

$$\left(\frac{\partial V}{\partial d}\right) = -4 \times 10^3 \times P \times d^{-3} \sin\left(\frac{\alpha}{2}\right) \quad (12)$$

$$\left(\frac{\partial V}{\partial \alpha}\right) = 10^3 \times P \times d^2 \cos\left(\frac{\alpha}{2}\right) \quad (13)$$

Thus, for a material having a hardness of 500 HV when tested with a 500 gf force, $d = 43.06 \mu\text{m}$, $\alpha = 136^\circ$, and

$$\sin\left(\frac{\alpha}{2}\right) = 0.927184.$$

10.7.1.1 Consider introducing a 1 % error into the hardness of the material through an error in either the applied force, the indenter constant or the measured diagonal length. In this case, the hardness would be $HV' = 505$ or $dV = 5$. Using Eq 11-13, the corresponding errors in the various parameters are as shown in Table 1. Thus a 1 % change in P or a 2.09 % error in α creates a 1 % error in the Vickers hardness number. However, only a 0.5 % error in the measured diagonal is needed to create a 1 % error in Vickers hardness. Furthermore, this analysis indicates that the calculated Vickers hardness number is not strongly influenced by errors in the angle of the indenter.

10.7.2 *Knoop*—Similarly, using Eq 1, it follows that:

$$dK = \left(\frac{\partial K}{\partial P}\right) dP + \left(\frac{\partial K}{\partial c_p}\right) dc_p + \left(\frac{\partial K}{\partial d}\right) dd \quad (14)$$

$$\frac{10^3}{c_p d^2} dP + \frac{10^3 P}{c_p^2 d^2} dc_p + \frac{-2 \times 10^3 P}{c_p d^3} dd \quad (15)$$

⁶ Supporting data have been filed at ASTM Headquarters. Request RR:E-04-1004.

⁷ The boldface numbers in parentheses refer to the list of references at the end of this standard.

TABLE 1 Vickers Hardness Analysis—1 % Error

Force, gf	Diagonal, μm	1 % Error		
		Δ P, gm	Δ Diagonal, μm	Δ Angle, °
10	6.090	0.100	-0.030	2.836
20	8.612	0.200	-0.043	2.836
50	13.617	0.499	-0.068	2.836
100	19.258	0.999	-0.096	2.836
200	27.235	1.998	-0.136	2.836
500	43.062	4.994	-0.215	2.836
1000	60.899	9.988	-0.304	2.836
				2° 50' 24"

and since the indenter has two different angles, A and B,

$$dc_p = \left(\frac{\partial c_p}{\partial A}\right) dA + \left(\frac{\partial c_p}{\partial B}\right) dB \tag{16}$$

$$\left(\frac{\partial c_p}{\partial \angle A}\right) = \frac{-\tan\left(\frac{\angle B}{2}\right)}{4 \sin^2\left(\frac{\angle A}{2}\right)} \tag{17}$$

and

$$\left(\frac{\partial c_p}{\partial \angle B}\right) = \frac{\cot\left(\frac{\angle A}{2}\right)}{4 \cos^2\left(\frac{\angle B}{2}\right)} \tag{18}$$

10.7.2.1 Using the differentials cited in 10.7.2, for the Knoop test at various forces, for a 1 % error in hardness that is, $KH' = 505$ or $dK = 5$, the corresponding errors in the force, diagonal measurement and indenter angle are as shown in Table 2. From this analysis it follows that 1 % error in P creates a 1 % error in HK, 0.5 % error in the measured diagonal creates a 1 % error in HK, and 1 % error in c creates a 1 % error in HK.

10.7.2.2 Since the indenter constant is composed of terms from two different angles, either a 4' 3" error in $\angle A$, or a 26' 20" error in $\angle B$ produces a 1 % error in HK. Unlike the Vickers indenter, the calculated Knoop hardness number is very strongly influenced by small errors in the two angles of

TABLE 2 Knoop Hardness Analysis—1 % Error

Force, gm	Diagonal, μm	1 % Error			
		Δ P gm	Δ diagonal, μm	Δ A, °	Δ B, °
10	16.87	0.10	-0.08	0.075	0.439
20	23.86	0.20	-0.12	0.075	0.439
50	37.72	0.50	-0.19	0.075	0.439
100	53.35	1.00	-0.27	0.075	0.439
200	75.45	2.00	-0.38	0.075	0.439
500	119.29	5.00	-0.60	0.075	0.439
1000	168.71	10.00	-0.84	0.075	0.439
				4' 30"	26' 20"

the indenter. The A angle, 172° 30' 00", is the most sensitive of these parameters. The actual value of c_p for each indenter can be calculated using the certified A and B angles provided by the indenter manufacturer. This will enhance the accuracy of the test measurements.

10.8 An interlaboratory test program was conducted in accordance with Practice E 691 to develop information regarding the precision, repeatability, and reproducibility of the measurement of Knoop and Vickers indentations. The test forces were 25, 50, 100, 200, 500, and 1000 gf on three ferrous and four nonferrous specimens (6, 7). Twelve laboratories measured the indentations, five of each type at each force on each sample. Additional details of this study are given in Appendix X3.

10.8.1 Tests of the three ferrous specimens revealed that nine laboratories produced similar measurements while two laboratories consistently undersized the indentations and one laboratory consistently oversized the indentations. These latter results were most pronounced as the force decreased and specimen hardness increased (that is, as the diagonal size decreased) and were observed for both Vickers and Knoop indentations. Results for the lower hardness nonferrous indentations produced better agreement. However, none of the laboratories that obtained higher or lower results on the ferrous specimens measured the nonferrous indentations.

10.8.2 *Repeatability Interval*—The difference due to test error between two test results in the same laboratory on the same material increases with increasing specimen hardness and with decreasing test force (see X3.4.4).

10.8.3 *Reproducibility Interval*—The difference in test results on the same material tested in different laboratories increased with increasing specimen hardness and with decreasing test force (see X3.4.5).

10.8.4 The within-laboratory and between-laboratory precision values improved as specimen hardness decreased and test force increased. The repeatability interval and reproducibility interval were generally larger than the precision estimate, particularly at low test forces and high specimen hardnesses.

11. Conversion to Other Hardness Scales or Tensile Strength Values

11.1 There is no generally accepted method for accurate conversion of Knoop or Vickers hardness numbers to other hardness scales or tensile strength values. Such conversions are limited in scope and should be used with caution, except for special cases where a reliable basis for the conversion has been obtained by comparison tests. Refer to Test Method E 140 for hardness conversion tables for metals.

12. Keywords

12.1 hardness; Knoop; microindentation; Vickers

(Mandatory Information)

A1. VERIFICATION OF KNOOP AND VICKERS HARDNESS TESTING MACHINES AND INDENTERS

A1.1 Scope

A1.1.1 This annex covers procedures for direct and indirect verification of microindentation hardness testing machines. These procedures are used to confirm that the machine is within calibration limits. The annex contains the geometric indenter specifications.

A1.1.1.1 Direct verification is mandatory for new or rebuilt machines and is the responsibility of the manufacturer.

A1.1.1.2 Indirect verification is used by the machine owner to verify the performance of a machine in service. If the machine fails indirect verification, it is the responsibility of the machine owner to upgrade the machine to pass direct verification.

A1.2 Indenter Geometry

A1.2.1 *Vickers Indenter:*

A1.2.1.1 The Vickers indenter for standard use, direct verification, and indirect verification shall have face angles of $136^{\circ} 0' \pm 30'$.

A1.2.1.2 The offset shall not exceed $0.5 \mu\text{m}$.

A1.2.1.3 The four faces of the diamond shall be equally inclined to the axis of the indenter to within $\pm 30'$, as shown in Fig. 2.

A1.2.1.4 Vickers diamond indenters used for calibrating test blocks shall have face angles of $136^{\circ} 0' \pm 6'$.

A1.2.2 *Knoop Indenter:*

A1.2.2.1 The ideal Knoop diamond indenter has an included longitudinal edge angle, $\angle A = 172^{\circ} 30'$, and included transverse edge angle, $\angle B = 130^{\circ} 0'$. The ideal indenter constant, $c_p = 0.07028$. For all indenters, c_p shall be within $\pm 1\%$ of the ideal value, $0.06958 \leq c_p \leq 0.07098$.

A1.2.2.2 The tolerance of $\angle A = 172^{\circ} 30'$, shall be $\pm 0.10^{\circ} 6'$.

A1.2.2.3 The corresponding $\angle B = 130^{\circ}$ must be contained within the dimensions listed in Table A1.1, and graphically as described by Fig. A1.1.

A1.2.2.4 The offset shall not be more than $1.0 \mu\text{m}$ in length for indentations greater than $15 \mu\text{m}$ in length, as shown in Fig. 1. For shorter indentations the offset should be proportionally less.

A1.2.2.5 The four faces of the diamond shall be equally inclined to the axis of the indenter to within $\pm 30'$, as shown in Fig. 1.

A1.2.3 The device used to verify the indenter shall be

TABLE A1.1 Angular Tolerances for Knoop Indenters

NOTE 1—These tolerances are schematically represented as the cross-hatched areas in Fig. A1.1.

A Angle, °	B Angle, °	
	Minimum	Maximum
172.4	128.97	129.85
172.6	130.15	131.02

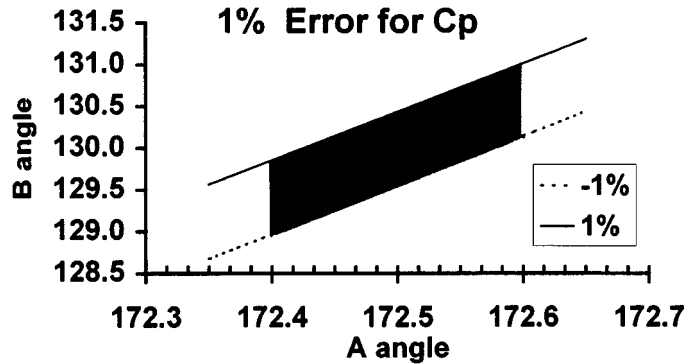

FIG. A1.1 Schematic Representing the Acceptable Regions of Knoop Indenter Angles

accurate to within 0.07° .

A1.3 Direct Verification of Microindentation Hardness Testing Machines

A1.3.1 Before commencing verification of the microindentation hardness testing machine, examine the tester to ensure that the machine has been properly set up and that the force can be applied without producing sufficient shock or vibration to adversely affect the test indentations.

A1.3.2 The separate verification of the applied force, indenter geometry, test cycle and calibration of the measuring microscope system is mandatory for new or rebuilt test machines and is the responsibility of the manufacturer.

A1.3.3 *Force Verification*—The force at the indenter shall be accurate within the limits listed in Table A1.2 and the forces shall be measured by one of the following two methods described in Practice E 4:

A1.3.3.1 Measuring by means of an elastic proving device previously calibrated to Class A accuracy of $\pm 0.2\%$, or

A1.3.3.2 Balancing against a force, accurate to $\pm 0.2\%$, applied by means of standardized masses with mechanical advantage.

A1.3.4 *Indenter Verification*—The indenters shall be verified according to the procedures described in A1.2.

A1.3.5 *Measuring Microscope Verification*—The measuring microscope or other device used to measure the diagonals of the indentation shall be calibrated against a certified ruled line scale, such as a stage micrometer. Line scale interval errors shall not exceed $0.1 \mu\text{m}$ or 0.05% , whichever is greater. The measuring microscope or other device shall be calibrated over the range of its potential use and a calibration factor shall be chosen so that the maximum error over the test range shall not exceed $\pm 0.5\%$.

TABLE A1.2 Accuracy of Applied Forces

Applied Force, gf	Accuracy, %, ±
$P < 200$	1.5
$P \geq 200$	1.0

A1.4 Indirect Verification of Microindentation Hardness Testing Machines

A1.4.1 Indirect verification of a microindentation hardness testing machine is conducted by making a series of test impressions on a standardized hardness test block. Indirect verification shall be performed with forces, indenters, and indentation lengths used by the laboratory. Indirect verification is performed by the user of the test machine or a commercial calibration agency. The frequency of indirect verification is dependent upon laboratory conditions, usage, or the requirements of laboratory certification documents. Indirect verification must be performed at least once every 12 months.

A1.4.2 Make five impressions on a standardized test block using the appropriate test force applied for 13 to 15 s.

A1.4.3 The microindentation hardness test machine is acceptably verified for that force if the mean diagonal length of the five indentations meets the requirements defined in A1.4.5 and A1.4.6.

A1.4.4 When the combination of block hardness and test force produces indentations with diagonals less than 20 μm long, indirect verification using standardized test blocks is not recommended. In these situations, the indentation measurement error represents a significant proportion of the diagonal length. This can lead to substantial deviations in hardness from the stated value. Examples of these errors are contained in Section 10 and Tables 1 and 2.

A1.4.5 Repeatability of Microindentation Hardness Tester:

A1.4.5.1 Repeatability, *R*, of the tester (%) is calculated by the following equation:

$$R = 100 \left(\frac{d_{\max} - d_{\min}}{\bar{d}} \right) \tag{A1.1}$$

where d_{\max} is the longest of the five diagonals (or mean diagonals), d_{\min} is the shortest of the five diagonals, and \bar{d} is the mean diagonal length. The repeatability is acceptable if it meets the requirements given in Table A1.3.

A1.4.5.2 The following is an example of a repeatability calculation. Assume that five Knoop indentations were made on a test block with a nominal hardness of 400 HK at the certified block test force of 300 gf and that the five readings are $d_1 = 103.9$, $d_2 = 104.8$, $d_3 = 102.3$, $d_4 = 102.8$ and $d_5 = 100.2$ μm, respectively. Therefore, $d_{\max} - d_{\min} = 104.8 - 100.2 = 4.6$ μm and $R = 100(4.6)/102.8 = 4.47$ %. According to Table A1.3, the repeatability for a test block with a hardness >250 to 650 HK should be <5 %. In this example, the tester met the repeatability requirement for this hardness test block and force. However, if these diagonals had been obtained using a test block with a nominal hardness of 700 HK and a certified test force of 500 gf, then the repeatability would be inadequate as

TABLE A1.3 Repeatability of Test Machines—Indirect Verification by Standardized Test Blocks^A

Hardness Range of Standardized Test Blocks		Force, gf	R, %, Less Than
Knoop	Vickers		
100 ≤ HK ≤ 250	100 ≤ HV ≤ 240	1 ≤ P < 500	6
250 < HK ≤ 650	240 < HV ≤ 600		5
HK > 650	HV > 600		4
100 ≤ HK ≤ 250	100 ≤ HV ≤ 240	500 ≤ P ≤ 1000	5
250 < HK ≤ 650	240 < HV ≤ 600		4
HK > 650	HV > 600		3

^AIn all cases, the repeatability limit is the greater of the percentage given or 1 μm.

Table A1.3 requires $R < 4$ % for a hardness >650 HK.

A1.4.6 Error of Microindentation Hardness Tester:

A1.4.6.1 The error, *E*, of the machine is:

$$E = \bar{d} - d_s \tag{A1.2}$$

The percent error, %*E*, is calculated by the following equation:

$$\%E = 100 \left(\frac{\bar{d} - d_s}{d_s} \right) \tag{A1.3}$$

where \bar{d} is the measured mean diagonal length and d_s is the reported certified mean diagonal length, μm.

A1.4.6.2 The error between the certified mean diagonal and the measured mean diagonal shall not exceed ± 2 % or ± 0.5 μm, whichever is greater.

A1.4.6.3 The following is an example of an error calculation based on the data given in A1.4.5.2, and a certified mean diagonal length for the test block, d_s , of 100.8 μm (420 HK300gf). Since $\bar{d} = 102.2$ μm, $(\bar{d} - d_s) = 102.2 - 100.8 = 2.0$ μm. Thus, $E = 1.98$ %. In this case, the percent error meets the maximum of ± 2 %, which is greater than ± 0.5 μm. For this example, $\bar{d} - d_s$ must be > ± 2.016 μm for the error to be above the limit of ± 2 %.

A1.5 Verification Report

A1.5.1 Report the following information:

- A1.5.1.1 Reference to this ASTM test method,
- A1.5.1.2 Method of verification (direct or indirect),
- A1.5.1.3 Identification of the hardness testing machine,
- A1.5.1.4 Means of verification (test blocks, elastic proving devices, etc.),
- A1.5.1.5 Type of indenter(s) and test force(s),
- A1.5.1.6 The results obtained,
- A1.5.1.7 Date of verification and reference to the calibration agency, and
- A1.5.1.8 Identity of the person performing the verification.

